

I Can Be Obedient

Lesson
30

Purpose To encourage each child to follow Jesus Christ's example by being obedient.

Preparation

1. Prayerfully study Exodus 20:12, Matthew 26:36–46, John 8:28–29, and Colossians 3:20. See also *Gospel Principles* (31110), chapter 35.

2. Make the following wordstrip:

Obedient

3. Print *I Can Obey* on a paper badge for each child. Bring tape or pins to attach a badge to each child's shirt or dress, or bring yarn to hang the badges around the children's necks.

4. Be prepared to sing or say the words to all three verses of "Quickly I'll Obey" (*Children's Songbook*, p. 197). The words to this song are included at the back of the manual.

5. Materials needed:

a. A Bible.

b. Picture 2-51, Geese with Goslings; picture 2-52, Jesus Praying in Gethsemane (Gospel Art Picture Kit 227; 62175).

6. Make the necessary preparations for any enrichment activities you want to use.

Note to teachers of older children: You may want to use enrichment activity 1 as the attention activity.

**Suggested
Lesson**

Development

Invite a child to give the opening prayer.

Follow up with the children if you encouraged them to do something during the week. You may want to have the children tell about ways they were good examples during the week.

Obedience Brings Happiness

Attention activity

Show picture 2-51, Geese with Goslings. Ask a child to hold the picture while you tell in your own words the following story about Elder Theodore M. Burton, who was a General Authority of the Church:

When Theodore M. Burton was only five years old, he visited his grandmother on her farm. Theodore liked to play outside at the farm. On this visit Theodore's grandmother warned him not to get too close to the hen with the baby chicks because the hen might think he was trying to hurt her babies. Theodore promised he would not get too close.

But when Theodore saw the fuzzy yellow chicks, he just had to touch one. The chick ran away, but the mother hen ran toward Theodore and pecked his hand with her hard beak. Theodore ran crying to his grandmother.

Theodore's grandmother hugged him until he stopped crying and then explained that the mother hen thought Theodore was going to hurt her babies. She was trying to protect her chicks when she pecked him.

Grandmother sent Theodore outside again, reminding him to stay away from the hen. She warned him not to get too close to the mother goose either, because she also had babies. The mother goose was bigger than the hen, so she might really hurt someone who touched her babies. Theodore promised he wouldn't touch the goslings.

Theodore stayed away from the mother hen. But when he saw the mother goose and her goslings, he moved closer to see them better. Spreading her wings and stretching her neck, the mother goose hissed loudly at him. Theodore was frightened and ran back into the house. (See Theodore M. Burton, "Friend to Friend: Grandmother's Lesson," *Friend*, Oct. 1973, pp. 18–19.)

Discussion

- Why did Theodore's grandmother tell him not to go near the hen or the goose?
- How did Theodore feel when he disobeyed his grandmother?
- Why did he feel this way?
- What do you think Theodore learned from this experience?

Tell the children that Theodore's grandmother told him that he had people to protect him, just as the hen and goose protected their babies. Explain that our parents and families and Heavenly Father and Jesus Christ watch over and protect us. They will teach us what to do to be safe and happy. It is important that we learn to obey them.

Wordstrip

Display the wordstrip "Obedient." Have the children say the word aloud with you a few times. Explain that we are obedient when we do what Heavenly Father, our parents, and our leaders want us to do.

Say the word *obey* and have the class repeat it. Explain that to obey means the same as being obedient.

We Can Obey Heavenly Father As Jesus Christ Did

Scripture

Explain that in the Bible, Jesus Christ taught that it is important to obey Heavenly Father. Read aloud the following phrases from John 8:28–29: "I do nothing of myself; but as my Father hath taught me. . . . For I do always those things that please him."

Explain that these are Jesus Christ's words, and they mean that Jesus always did what Heavenly Father wanted him to do. He did only the things that he knew would make Heavenly Father happy.

Scripture story

Display picture 2-52, Jesus Praying in Gethsemane, and briefly tell the story found in Matthew 26:36–39.

Read aloud what Jesus Christ said in his prayer: "O my Father, if it be possible, let this cup pass from me" (Matthew 26:39). Explain that Jesus did not want to suffer and die if there were another way to help us return to Heavenly Father.

Read aloud what Jesus said next: “Nevertheless not as I will, but as thou wilt” (Matthew 26:39). Explain that this means Jesus was willing to do what Heavenly Father wanted, even though it was not easy. Explain that we will not be asked to do something as difficult as what Jesus did; however, we should obey Heavenly Father in whatever he wants us to do.

- What are some things Heavenly Father has asked us to do? (Answers may include pray, love one another, be baptized and confirmed, and be honest.)

We Can Obey Our Parents

Scripture discussion

Explain that if we obey Heavenly Father, we will also obey our parents. (If some of the children in your class do not live with their parents, adjust this discussion as needed. For example, children should also obey their grandparents.) Point out that one of the Ten Commandments tells us to obey our parents. Read aloud the first part of Exodus 20:12: “Honour thy father and thy mother.” Explain that obeying our parents is one way to honor them.

- Why should we obey our parents?

Read aloud Colossians 3:20 (remind the children that *the Lord* is another name for Jesus Christ). Help the children memorize the first part of the verse: “Children, obey your parents in all things.”

- How do you feel when you obey your parents?
- How do your parents feel when you obey them?

Song

Have the children stand and sing or say the words to all three verses of “Quickly I’ll Obey.”

Encourage the children to decide now that they will obey Heavenly Father and their parents.

Story

Tell a story about a child who was happy because he or she obeyed his or her parents. You may want to use the following story:

Kathryn loved to play at her friend April’s house. Kathryn’s mother had said Kathryn could play for one hour. When April’s mother said the hour was up, it was hard for Kathryn to leave. She wanted to finish the game that she and April were playing. Kathryn thought for a moment and decided she would go home as her mother had told her to do. Quickly she said good-bye to April and ran home.

When Kathryn got home, her grandmother was waiting for her. Grandmother wanted Kathryn to come spend the night at her house, but she was in a hurry to get home. If Kathryn had not come home when her mother had told her to, she would have missed the chance to visit her grandmother.

- How do you think Kathryn felt?

Emphasize that we will not always receive an exciting reward when we are obedient, but we will have a happy, peaceful feeling. This feeling comes from knowing that we have chosen to do what is right.

Summary

Child participation

Invite the children, one at a time, to tell about a time when they were obedient and how they felt, or about a way they can be obedient in the future (such as

keeping one of Heavenly Father's commandments, asking parents' permission before going out to play, helping clean up the home, or coming the first time a parent calls).

At the end of each child's turn, give him or her an "I Can Obey" badge. Encourage the children to keep their badges where they can see them often, so the badges will help them remember to obey. Suggest that the children explain their badges to their families and share what they learned from the lesson today.

Testimony

Share your testimony of how obeying Heavenly Father and your parents has blessed your life. You may want to tell about a time when obedience made you happy.

Encourage the children to quickly obey their parents during the coming week.

Invite a child to give the closing prayer.

Enrichment Activities

Choose from the following activities those that will work best for the children in your class. You can use them in the lesson itself or as a review or summary. For additional guidance, see "Class Time" in "Helps for the Teacher."

1. Draw a large circle on the chalkboard with two smaller circles inside it (see illustration).

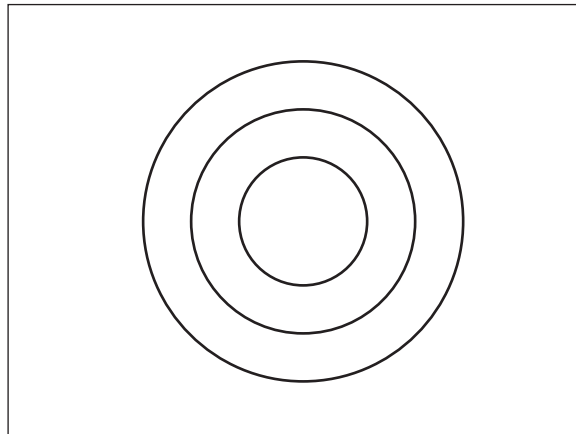

Explain that the object of this activity is to make an X inside the smallest circle while wearing a blindfold. Ask for a volunteer to try it. Blindfold the volunteer and give him or her a piece of chalk. Turn the blindfolded child around two or three times and then place him or her in front of the chalkboard. Have the child make an X on the chalkboard. Then ask the child to make another X after receiving instructions about where to place the X. Have a second child give the blindfolded child instructions such as "higher," "lower," "to the left," "to the right."

Look at the two markings and discuss how much better the blindfolded child did when he or she obeyed the instructions of the other child.

- Why did (blindfolded child's name) do better at placing the X when she (he) obeyed the instructions?

Allow each child who wants to participate to be blindfolded and try to put an X in the circle while another child gives instructions.

Point out that the blindfolded children were more successful at placing the marks in the circle when they obeyed the instructions of someone who could see the circles better. Explain that sometimes Heavenly Father and our parents can see things in our lives better than we can. They give us instructions to help us. When we obey Heavenly Father and our parents, we will be happy.

2. Tell the following story in your own words:

Matthew loved matches. If there were candles to be lit or a fire to be started, he always wanted to help. Sometimes his parents let him strike a match, but they always stood close by to make sure he was careful.

One day when his parents were not in the room, Matthew saw a box of matches on the table. He thought about what fun it would be to light every one of the matches himself. He was certain he would be careful.

Then Matthew thought about how his mother had told him many times that matches were not toys and that he must never use them without permission. Quietly Matthew turned away from the matches and went outside to play.

Talk with the children about the possible consequences if Matthew had taken the matches. Emphasize that Matthew's obedience was helpful to the family even though no one was aware of it.

You may want to continue the discussion by asking:

- What should Matthew do if his older brother tells him to bring the matches to their bedroom so they can play with them?

Explain that when someone tells us to do something we know is wrong, we should not obey. Heavenly Father doesn't expect us to obey when we are told to do something wrong.

3. Prepare pieces of paper with simple instructions such as the following:

- Erase the chalkboard.
- Shake hands with each member of the class.
- Sing or say the words to "Do As I'm Doing."
- Say something kind about each class member.
- Tell five things that you are thankful for.
- Act out something that you will do for a family member during the week.

Put the pieces of paper in a container. Have the children take turns choosing a paper from the container and obeying the instructions written on it.

4. Before class, prepare and hide clues for a small treasure hunt in your classroom. Each clue should lead the children to the next clue until the final clue leads to the treasure. You may want to have a small treat or gift for each child as the treasure at the end of the hunt.

Discuss with the children how they must obey the instructions on each clue to find the treasure. Read the first clue aloud to start the treasure hunt.

After the children have finished the treasure hunt, help them understand that if we obey our Heavenly Father, he will give us the greatest treasure of all: he will let us live with him forever.

5. Review the story of Noah and the ark, as found in Genesis 6–8. Explain that because Noah was obedient, he and his family were saved from the flood. Encourage the children to obey the commandments of Heavenly Father and Jesus Christ, as Noah did.

Give each child a copy of the handout at the end of the lesson. Let the children color the picture of the ark and then draw a picture showing how they can be obedient.

Noah Was Obedient

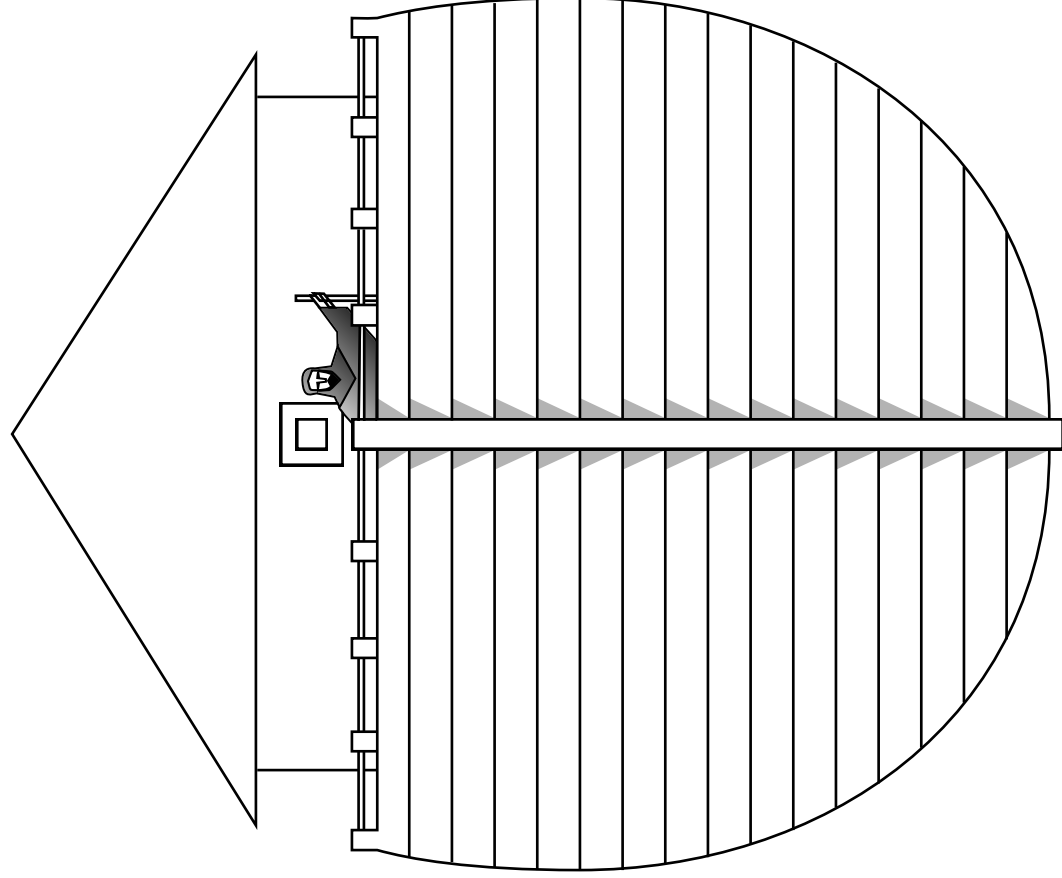

I Can Be Obedient