

Na vakabauta e lako mai ena rogoci ni vosa ni Kalou (Roma 10:17).

Rokataka qai kotiva tani mai na yaloyalo kei na waqanivola. Lobika na waqanivola ena laini makataki, ka vakabira vata ena yasana lekaleka. Vakacuruma na itaba ni sala ni noda rogoca na vosa ni Kalou ena loma ni waqanivola.

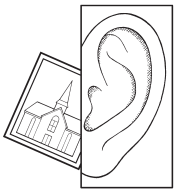
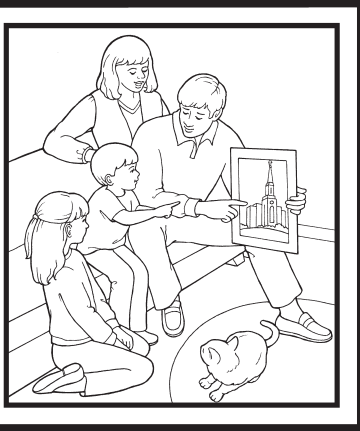
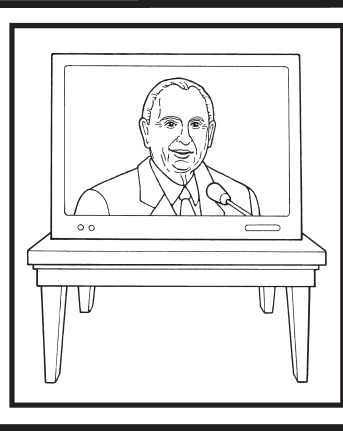
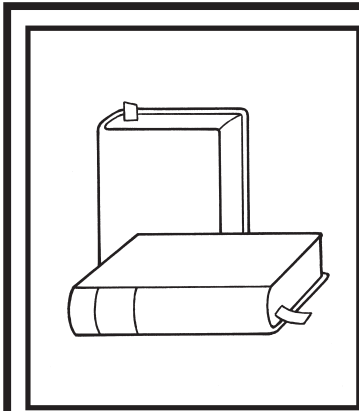

Na vakabauta e lako mai ena rogoci ni vosa ni Kalou.

(Roma 10:17)