



BOOK OF MORMON 2020

Come, Follow Me — For Primary

Living, Learning, and Teaching the Gospel of Jesus Christ

BOOK OF MORMON 2020

Come, Follow Me— For Primary

Living, Learning, and Teaching the Gospel of Jesus Christ

Published by
The Church of Jesus Christ of Latter-day Saints
Salt Lake City, Utah

© 2019 by Intellectual Reserve, Inc.
All rights reserved.
Version: 10/17
15157 000
Printed in the United States of America

Comments and corrections are appreciated. Please send them, including errors, to comefollowme@ChurchofJesusChrist.org.

Contents

Introductory Materials

| | |
|--|------------|
| You Are a Teacher of Children | v |
| Using <i>Come, Follow Me—For Primary</i> | vi |
| Additional Resources for Teaching Children | viii |
| Meeting the Needs of Younger Children | x |
| Meeting the Needs of Children with Disabilities | xii |
| A Pattern for Teaching | xiii |
| December 30–January 5: Introductory Pages of the Book of Mormon | 1 |
| January 6–12: 1 Nephi 1–7 | 5 |
| January 13–19: 1 Nephi 8–10 | 9 |
| January 20–26: 1 Nephi 11–15 | 13 |
| January 27–February 2: 1 Nephi 16–22 | 17 |
| February 3–9: 2 Nephi 1–5 | 21 |
| February 10–16: 2 Nephi 6–10 | 25 |
| February 17–23: 2 Nephi 11–25 | 29 |
| February 24–March 1: 2 Nephi 26–30 | 33 |
| March 2–8: 2 Nephi 31–33 | 37 |
| March 9–15: Jacob 1–4 | 41 |
| March 16–22: Jacob 5–7 | 45 |
| March 23–29: Enos—Words of Mormon | 49 |
| March 30–April 12: Easter | 53 |
| April 13–19: Mosiah 1–3 | 57 |
| April 20–26: Mosiah 4–6 | 61 |
| April 27–May 3: Mosiah 7–10 | 65 |
| May 4–10: Mosiah 11–17 | 69 |
| May 11–17: Mosiah 18–24 | 73 |
| May 18–24: Mosiah 25–28 | 77 |
| May 25–31: Mosiah 29–Alma 4 | 81 |
| June 1–7: Alma 5–7 | 85 |
| June 8–14: Alma 8–12 | 89 |
| June 15–21: Alma 13–16 | 93 |
| June 22–28: Alma 17–22 | 97 |
| June 29–July 5: Alma 23–29 | 101 |
| July 6–12: Alma 30–31 | 105 |
| July 13–19: Alma 32–35 | 109 |

| | |
|---|-----|
| July 20–26: Alma 36–38 | 113 |
| July 27–August 2: Alma 39–42 | 117 |
| August 3–9: Alma 43–52 | 121 |
| August 10–16: Alma 53–63 | 125 |
| August 17–23: Helaman 1–6 | 129 |
| August 24–30: Helaman 7–12 | 133 |
| August 31–September 6: Helaman 13–16 | 137 |
| September 7–13: 3 Nephi 1–7 | 141 |
| September 14–20: 3 Nephi 8–11 | 145 |
| September 21–27: 3 Nephi 12–16 | 149 |
| September 28–October 11: 3 Nephi 17–19 | 153 |
| October 12–18: 3 Nephi 20–26 | 157 |
| October 19–25: 3 Nephi 27–4 Nephi | 161 |
| October 26–November 1: Mormon 1–6 | 165 |
| November 2–8: Mormon 7–9 | 169 |
| November 9–15: Ether 1–5 | 173 |
| November 16–22: Ether 6–11 | 177 |
| November 23–29: Ether 12–15 | 181 |
| November 30–December 6: Moroni 1–6 | 185 |
| December 7–13: Moroni 7–9 | 189 |
| December 14–20: Moroni 10 | 193 |
| December 21–27: Christmas | 197 |
| Appendix | |
| Instructions for Singing Time and the Children’s Sacrament Meeting Presentation | 201 |

Feel free to adapt the schedule to account for Sundays when regular Church meetings are not held. For example, you could cover two weeks of outlines in one Sunday lesson when ward or stake conferences or temple dedications are held. You may also need to adapt the study schedule if in your area Easter and Christmas are observed on dates other than those listed in this resource.



You Are a Teacher of Children

You have been called of God to teach His children in the Savior's way. You were set apart to this calling by the authority of His holy priesthood. Even if you are not an experienced teacher, as you live worthily, pray daily, and study the scriptures, Heavenly Father will grant you the influence and power of the Holy Spirit to help you succeed (see 2 Nephi 33:1).

Those entrusted to your care are Heavenly Father's children, and He knows what they need and how best to reach them. Through the Holy Ghost, God will guide you as you prepare and while you are teaching. He will reveal to you what you should say and what you should do (see 2 Nephi 32:5).

In all aspects of their lives, these precious children are constantly absorbing information, forming and refining their opinions, and making and sharing discoveries. This is especially true with the gospel, for children are ready and eager to learn its simple

truths. Their faith in spiritual things is strong and pure, and they see every moment as a learning opportunity. They willingly act on what they have learned, even if their understanding is still incomplete. This is how we should all receive the gospel. As the Savior taught, "Whosoever shall not receive the kingdom of God as a little child shall in no wise enter therein" (Luke 18:17).

The calling to teach children is a sacred trust, and it is normal to feel overwhelmed at times. But remember that your Heavenly Father called you, and He will never forsake you. This is the Lord's work, and as you serve "with all your heart, might, mind and strength" (D&C 4:2), He will enlarge your capacities, gifts, and talents, and your service will bless the lives of the children you teach.



Using *Come, Follow Me—For Primary*

Preparing to Teach in Primary

Personal and family study at home should be the center of gospel learning. This is true for you and for the children you teach. As you prepare to teach, start by having your own experiences in the scriptures. Your most important preparation will occur as you search the scriptures and seek the inspiration of the Holy Ghost.

Come, Follow Me—For Individuals and Families is also an important part of both your personal study and your preparation to teach. It will help you gain a deeper understanding of the doctrinal principles found in the scriptures.

During your preparation, thoughts and impressions will come to you about the children you teach. You will receive insights about how the principles in the scriptures will bless their lives. You will be guided to inspire them to discover those principles as they learn from the scriptures for themselves and with their families. Remember to be sensitive to children whose family circumstances may not support regular family scripture study and family home evening.

Teaching Ideas

As you prepare to teach, you might gain additional inspiration by exploring the teaching outlines in this resource. Don't think of these ideas as step-by-step instructions but rather as suggestions to spark your own inspiration. You know these children—and you will get to know them even better as you interact with them in class. The Lord knows them too, and He will inspire you with the best ways to teach and bless them.

Many other resources are available for you to use as you prepare, including ideas in *Come, Follow Me—For Individuals and Families* and Church magazines. For more information about these and other resources, see “Additional Resources for Teaching Children” in this resource.

Some Things to Keep in Mind

- Parents have the main responsibility to teach their children. As a teacher, you have an important responsibility to support, encourage, and build upon gospel learning in the home. Be sensitive to children whose parents do not teach the gospel in

their home. Include all children in gospel discussions, regardless of their home circumstances.

- Repetition is good. Children learn gospel truths more effectively when these truths are taught repeatedly through a variety of activities. If you find that a learning activity is effective for the children, consider repeating it, especially if you are teaching younger children. You might also review an activity from a previous lesson.
- Heavenly Father wants you to succeed as a teacher. He has provided many resources to help you, including teacher council meetings. In these meetings you can counsel with other teachers about challenges you face. You can also discuss and practice principles of Christlike teaching.
- If you are teaching younger children and need additional help, see “Meeting the Needs of Younger Children” in this resource.

- This resource includes outlines for every week of the year except for the two Sundays when general conference is held. On Sundays when Primary is not held because of stake conference or for any other reason, families should continue reading the Book of Mormon at home according to the schedule outlined. In order to keep your Primary class on schedule, you may choose to either skip a lesson or combine two lessons. To avoid confusion, Primary presidents may wish to advise teachers about these adjustments ahead of time.



Additional Resources for Teaching Children

These resources can be found in the Gospel Library app and on ChurchofJesusChrist.org.

Come, Follow Me—For Individuals and Families

You can adapt activities from *Come, Follow Me—For Individuals and Families* for use in your Primary class. Don't worry if children have already done these activities with their families at home; repetition helps children learn. Children may want to tell you about how they did the activities with their families and what they learned.

Hymns and Children's Songbook

Sacred music invites the Spirit and teaches doctrine in a memorable way. In addition to the print versions of *Hymns* and *Children's Songbook*, you can find audio and video recordings of many hymns and children's songs at music.ChurchofJesusChrist.org and in the Sacred Music and media library apps.

Behold Your Little Ones

Many of the topics addressed in the nursery manual *Behold Your Little Ones: Nursery Manual* are similar to those you will teach in Primary. Especially if you teach younger children, consider looking in the nursery manual for additional songs, stories, activities, and crafts.

Friend and Liahona Magazines

The *Friend* and *Liahona* magazines provide stories and activities that can supplement the principles

that you are teaching from *Come, Follow Me—For Primary*.

Book of Mormon Stories

Book of Mormon Stories can help children learn the doctrine and stories found in the Book of Mormon. You can also find videos of these stories at medialibrary.ChurchofJesusChrist.org.

Media Library

Artwork, videos, and other media can help children visualize the doctrine and stories found in the Book of Mormon. Visit medialibrary.ChurchofJesusChrist.org to browse the Church's collection of media resources, including the Book of Mormon Videos collection, which depicts events in the Book of Mormon. The media library is also available as a mobile app.

Gospel Art

Artwork can help the children visualize the doctrine and stories found in the Book of Mormon. Many images that you can use in class are found in the *Gospel Art Book*, at medialibrary.ChurchofJesusChrist.org, and in the media library app.

True to the Faith

If you need additional help understanding the basic principles you will teach the children, consider looking in *True to the Faith*. This reference provides simple explanations of gospel topics, listed in alphabetical order.



Teaching in the Savior's Way

Teaching in the Savior's Way can help you learn about and apply principles of Christlike teaching. These principles are discussed and practiced in teacher council meetings.



Meeting the Needs of Younger Children

Children are ready and eager to learn the gospel if it is presented in a way they can understand. Especially if you teach younger children, consider using the following types of activities to help them learn.

- *Sing.* Hymns and songs from *Children's Songbook* teach doctrine powerfully. Use the topics index at the back of the *Children's Songbook* to find songs that relate to the gospel principles you are teaching. Help the children relate the message of the songs to their lives. For example, you might ask questions about words or phrases in the lyrics. In addition to singing, children can do actions that go with the songs or just listen to the songs as background music while they are doing other activities.
- *Listen to or act out a story.* Young children love stories—from the scriptures, from your life, from Church history, or from Church magazines. Look for ways to involve them in storytelling. They can hold pictures or objects, draw pictures of what they are hearing, act out the story, or help tell the story. Help children recognize the gospel truths in the stories you share.
- *Read a scripture.* Young children may not be able to read very much, but you can still engage them in learning from the scriptures. You may need to focus on a single verse, key phrase, or word. As you read a scripture out loud, you could invite children to stand up or raise their hands when they hear a specific word or phrase you want to focus on. They may even be able to memorize short phrases from the scriptures if they repeat them a few times. As they hear the word of God, they will feel the Spirit.
- *Be active.* Because young children are often energetic, plan ways to let them move around—marching, jumping, skipping, bending, walking, and other actions that relate to the principle or story you are teaching. These actions can also be effective as you sing together.
- *Look at a picture or watch a video.* When you show children a picture or video related to a gospel principle or scripture story, ask them questions that help them learn from what they are seeing. For example, you could ask, “What is happening in this picture or video?” or “How does it make you feel?” The Gospel Library

app, medialibrary.ChurchofJesusChrist.org, and children.ChurchofJesusChrist.org are good places to look for videos.

- *Share experiences.* Young children may not have as much to share as older children do, but if you give them specific guidance, they can share their feelings and experiences about what they are learning.
- *Create.* Children can build, draw, or color something related to the story or principle they are learning. Encourage them to take their creation home and share it with family members to help the children remember what they learned.
- *Participate in object lessons.* A simple object lesson can help children understand a gospel principle that is difficult to comprehend. When using object lessons, find ways to let the children participate. They will learn more from an interactive experience than from just watching a demonstration.
- *Role-play.* When children role-play a situation they will likely encounter in real life, they are better able to understand how a gospel principle applies to their lives.
- *Repeat activities.* Young children may need to hear concepts multiple times to understand them. Don't be afraid to repeat stories or activities often, even during the same lesson. For example, you might share a scripture story several times in different ways during a lesson—by reading from the scriptures, summarizing in your own words, showing a video, letting the children help you tell the story, inviting them to act out the story, and so on. If an activity used in class is also repeated at home, the repetition will help the children learn and remember.

- *Interact with others.* Children are developing social skills and often enjoy learning and playing with their peers. Create opportunities for them to share, take turns, and cooperate while they learn.
- *Participate in a variety of activities.* Young children typically have short attention spans, and they have different learning styles. Use a variety of activities, and pay attention to signs that the children need a change of pace. For example, you may need to alternate frequently between quiet and lively activities.

Part of your role as a teacher of young children—in addition to teaching gospel principles—is to help the children learn how to participate appropriately in a Church class. For example, they may need to learn about taking turns, sharing, respecting others, and so on. Some teachers create charts with an assignment for each child to participate in the class in a specific way (such as by saying a prayer, holding a picture, or passing out papers). The assignments can change each week. This helps the children take turns and focus on appropriate classroom behavior.

Children—especially younger children—often benefit from a regular, predictable routine. Because young children have short attention spans and sometimes struggle to focus for an entire class, it is usually best if this routine includes frequent transitions from one activity to another. For example, your class routine might include occasional breaks to play a game, color a picture, sing a song, and so on.





Meeting the Needs of Children with Disabilities

Primary leaders are responsible to teach the gospel of Jesus Christ to all children, including those with disabilities. In Primary, every child should be welcomed, loved, nurtured, and included. In this atmosphere it is easier for all children to understand the love of our Heavenly Father and Jesus Christ and to feel and recognize the influence of the Holy Ghost. The following ideas can help you meet the needs of children with disabilities.

- *Learn about the child's specific needs.* The best way to do this is to talk to the child's parents or caregivers. Find out how the child best learns and what strategies are most helpful. You could also counsel with other Primary leaders and teachers who have experience and insights to share.
- *Create a positive atmosphere in which every child feels safe and loved.* Learn the names of all the children in your class, and help them feel accepted, loved, and included. Children with disabilities are often criticized, so look for opportunities to praise them for positive behaviors.
- *Make adjustments so everyone can participate.* Small changes can be made to activities to ensure that all children can learn, including those with physical limitations or learning difficulties. For instance, if an activity suggests showing a picture, you could sing a related song instead to include children with visual impairments.
- *Establish consistent classroom routines and structure.* One way to do this is to create a poster with the class schedule outlining how the class will flow. Your schedule might include prayers, teaching time, and activity time. This can help reduce feelings of uncertainty which may increase anxiety in some children.
- *Use visual cues.* Children with learning disabilities or behavioral challenges may benefit from visual cues, such as pictures modeling appropriate behaviors like raising one's hand before answering a question.
- *Understand why challenging behaviors happen.* Learn about disabilities or circumstances that may influence a child to act inappropriately. Pay careful attention to what is happening when challenging behaviors arise. Prayerfully consider how to modify the situation in order to better support the child.



A Pattern for Teaching

In this resource, you will find the following three-step pattern repeated in each outline: invite sharing, teach the doctrine, and encourage learning at home. In many cases, as you teach, the elements of this pattern may overlap or occur in a different order. For example, consider that sharing is an opportunity to teach the doctrine, and teaching doctrine should involve invitations to share. Likewise, encouraging learning at home can happen throughout a class discussion. Allow adjustments in this pattern to happen naturally, following the promptings of the Spirit to meet the needs of the children you teach.



Invite Sharing

As part of every class, invite the children to share their feelings, insights, and experiences about the principles you are teaching. Their comments may include experiences they have had learning at home. You might also review what they learned the previous week and ask how it has influenced their lives.



Teach the Doctrine

Come, Follow Me—For Individuals and Families can help you better understand the doctrine you will teach to the children. Consider what scripture verses, quotations, experiences, questions, and other resources you might share to help the children learn and act on gospel principles. Look for creative ways to help them be excited about what they are learning.



Encourage Learning at Home

Because the home is the center of gospel learning, one of your objectives as a Primary teacher is to encourage learning at home. How can you help the children share with their families what they learned in class? How can you encourage children and their parents to continue to learn from the Book of Mormon at home?



DECEMBER 30–JANUARY 5

Introductory Pages of the Book of Mormon

“ANOTHER TESTAMENT OF JESUS CHRIST”

Begin your preparation to teach by reading the Book of Mormon’s title page and introduction; the testimonies of the Three Witnesses, the Eight Witnesses, and the Prophet Joseph Smith; and “A Brief Explanation about the Book of Mormon.” Ponder how you can inspire the children to learn from the Book of Mormon.

RECORD YOUR IMPRESSIONS _____



Invite Sharing

Invite the children to share stories they know from the Book of Mormon, using pictures 67–86 in the *Gospel Art Book* or other pictures you have.



Teach the Doctrine: Younger Children

TITLE PAGE OF THE BOOK OF MORMON

The Book of Mormon can help me have faith in Jesus Christ.

Help the children see that the purpose of the Book of Mormon is to bear testimony of Jesus Christ.

Possible Activities

- Hold up a copy of the Book of Mormon, and point out the subtitle, *Another Testament of Jesus Christ*. Let the children take turns saying, “Another testament of Jesus Christ.” Briefly tell the children how the Book of Mormon has strengthened your faith in Jesus Christ.
- Tell a story from the Book of Mormon that teaches about Jesus Christ, such as the account of Samuel the Lamanite prophesying of Christ (see Helaman 14–16), the Savior blessing children (see 3 Nephi 17), or the Brother of Jared seeing Jesus Christ (see Ether 2–3). Chapters from *Book of Mormon Stories* (and the corresponding videos on ChurchofJesusChrist.org) can help. Point out to the children what we learn about Jesus from these stories. Tell them that they will learn many things about Jesus Christ from the Book of Mormon this year.
- Sing a song about the Book of Mormon, such as “Book of Mormon Stories” (*Children’s*

Songbook, 118). Sing the song together several times, and let the children take turns holding a picture of the Savior while you sing.

INTRODUCTION TO THE BOOK OF MORMON

The Book of Mormon is the keystone of our religion.

President Thomas S. Monson explained: “If [the Book of Mormon] is true—and I solemnly testify that it *is*—then Joseph Smith was a prophet . . . , The Church of Jesus Christ of Latter-day Saints is the Lord’s Church on the earth, and the holy priesthood of God has been restored” (“The Power of the Book of Mormon,” *Ensign* or *Liahona*, May 2017, 86–87).

Possible Activities

- Read to the children the following statement by Joseph Smith in the introduction to the Book of Mormon: “The Book of Mormon [is] the keystone of our religion.” Explain that just as a keystone holds together the rest of an arch, our testimony of the Book of Mormon holds up and strengthens our testimony of other things, like Joseph Smith and the gospel.
- Invite a parent of one of the children to share how he or she gained a testimony of the Book of Mormon. Read with the children the invitation at the end of the introduction to the Book of Mormon, and help them act out things they can do to gain their own testimonies.

“THE TESTIMONY OF THE PROPHET JOSEPH SMITH”

The Book of Mormon was given to us by the power of God.

Joseph Smith’s testimony can help the children understand the Book of Mormon’s divine purpose.

Possible Activities

- Briefly tell the children the story of the coming forth of the Book of Mormon as described in “The Testimony of the Prophet Joseph Smith.” You might also use “Chapter 1: How We Got the Book of Mormon” (*Book of Mormon Stories*, 2–4, or the corresponding video on ChurchofJesusChrist.org). Help the children act out the story a few times as you retell it.
- Show the children an image of characters from the golden plates. Explain that God helped Joseph translate these characters into words we can read and understand.

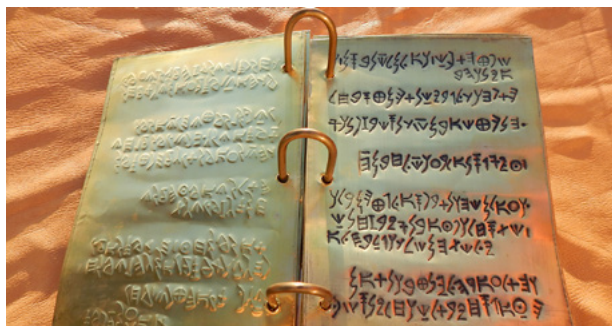

Joseph Smith translated the characters written on the golden plates.



Teach the Doctrine:
Older Children

TITLE PAGE OF THE BOOK OF MORMON

The Book of Mormon helps me have faith in Jesus Christ.

Remember that your purpose in teaching the children about the Book of Mormon is to build their faith in the Savior.

Possible Activities

- Divide the class into pairs. Invite each pair to read the second paragraph of the title page of

the Book of Mormon, looking for something that tells them what the Book of Mormon is meant to do. Then invite each pair to share with the class.

- Help the children find on the title page the phrase “to the convincing of the Jew and Gentile that Jesus is the Christ.” How can the Book of Mormon convince us that Jesus is the Christ? Invite them to share a story from the Book of Mormon that has strengthened their faith in Christ, or share one of your own.

INTRODUCTION TO THE BOOK OF MORMON

The Book of Mormon is the keystone of our religion.

Gaining a testimony of the Book of Mormon will help the children know that The Church of Jesus Christ of Latter-day Saints is God’s true Church.

Possible Activities

- Ask the children to pretend you have never heard of the Book of Mormon before. Invite them to work with a partner to think of ways they could explain to you what it is and where it came from, using details from the introduction. Then let each pair take turns teaching you. The picture *The Bible and the Book of Mormon Testify of Christ* (ChurchofJesusChrist.org) could also help.
- Invite a child to read Joseph Smith’s statement in the sixth paragraph of the introduction. Using this week’s activity page, explain how a keystone holds up an arch. According to the last paragraph of the introduction, what are some other things we know once we have a testimony that the Book of Mormon is true?

“THE TESTIMONY OF THREE WITNESSES”; “THE TESTIMONY OF EIGHT WITNESSES”

I can be a witness of the Book of Mormon.

How can you help the children gain and share their own testimonies of the Book of Mormon?

Possible Activities

- Invite the children to describe something they have seen that no one else in the class has seen. Explain that the Book of Mormon contains the testimonies of 11 people besides Joseph Smith who saw the golden plates from which the Book of Mormon was translated. Read the testimonies together. Why did these witnesses want other people to know about their testimonies?
- Ask if any of the children would like to share how they know the Book of Mormon is true. Read together Moroni 10:3–5, and invite each child to read the Book of Mormon this year and gain or strengthen his or her testimony that it is true. Tell the children how you gained your testimony of the Book of Mormon.



Encourage Learning at Home

If possible, ensure that each child has a copy of the Book of Mormon, and invite them to start reading it on their own and with their families.

Improving Our Teaching

Seek your own inspiration. Rather than viewing these outlines as instructions that you must follow as you teach, use them as a source of ideas to spark your own inspiration as you ponder the needs of the children you teach.

The Book of Mormon is the keystone of our religion.

Color each stone as you finish reading each book in the Book of Mormon

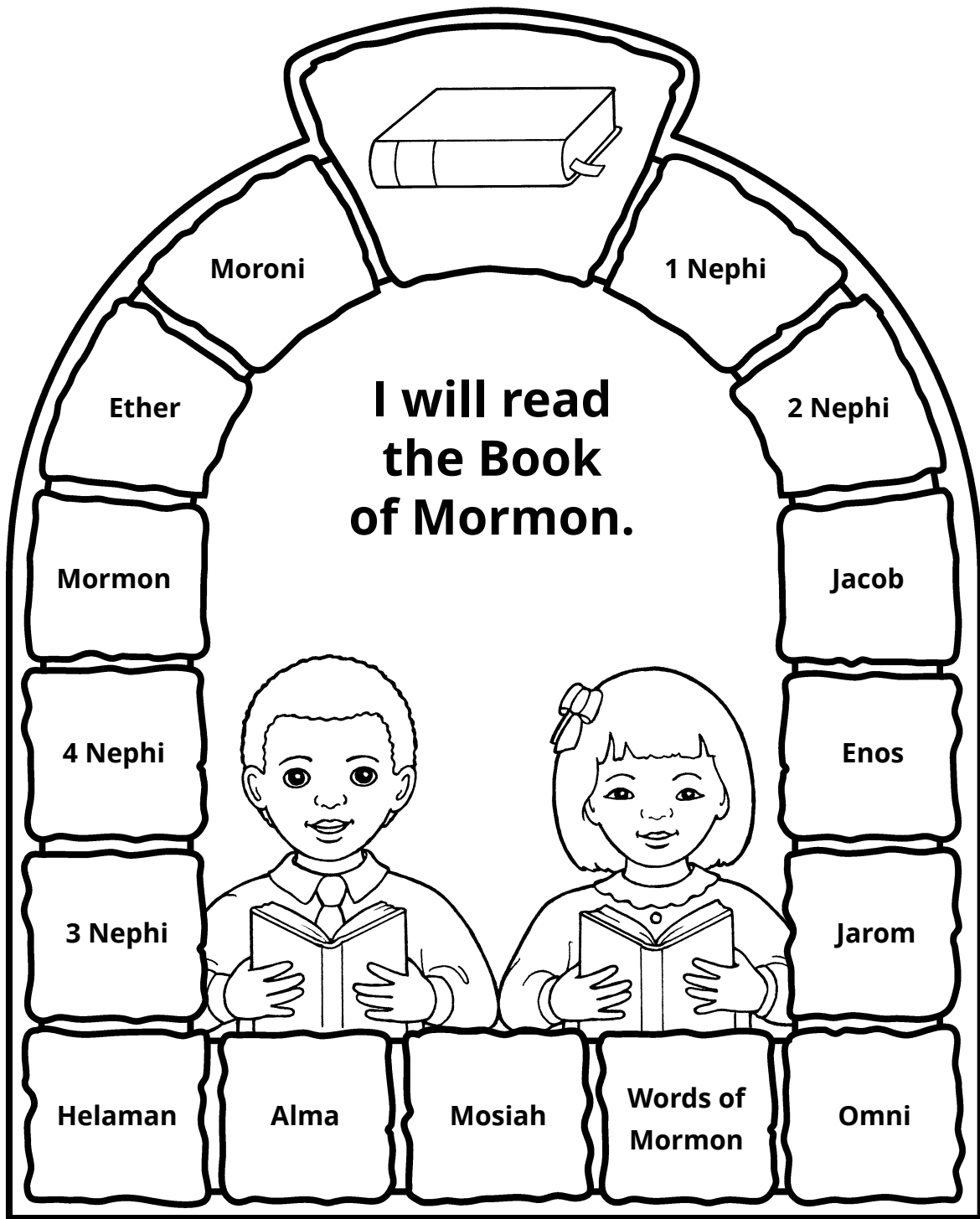



Lehi Traveling Near the Red Sea, by Gary Smith

JANUARY 6-12

1 Nephi 1-7

“I WILL GO AND DO”

As you read 1 Nephi 1-7, think about verses, experiences, questions, and other resources you feel inspired to use to teach the children. The activities in this outline can be adapted for older or younger children.

RECORD YOUR IMPRESSIONS _____



Invite Sharing

Some of the children in your class may have already heard about or read the experiences of Nephi’s family in 1 Nephi 1-7. Invite them to share what they know. If the children don’t know very much about Nephi’s experiences, give them an opportunity at the end of the lesson to share what they learned.



Teach the Doctrine: Younger Children

1 NEPHI 2:16

I need my own testimony.

Nephi came to believe his father’s words because he had desires to know for himself and he prayed to the Lord. Help the children learn from his example.

Possible Activities

- Bring a closed box with a picture of the Savior inside, and give each child a turn to find out for himself or herself what is inside the box. Tell the children that Nephi wanted to have His own testimony that the Lord had commanded his family to leave Jerusalem. Ask the children to listen for what Nephi did to gain his own testimony as you read 1 Nephi 2:16. Testify that just as we each had to open the box to find out what was inside, we all need to ask God to gain our own testimony.
- Bring pictures or objects that represent things that children might seek a testimony of, such as a picture of Jesus Christ, the Book of Mormon, or a picture of the living prophet. Invite the children to choose a picture or object and share their testimonies of that thing with the class.

1 NEPHI 2:2-4; 3-4

God will help me keep His commandments.

How can you use these accounts to help the children understand that God helps us keep His commandments, even when they seem hard to obey?

Possible Activities

- Read 1 Nephi 2:2–4 to the children, and display a few pictures of items that Lehi’s family might have taken with them into the wilderness, such as a tent, blankets, and bows and arrows. Ask them to imagine how they might feel if they had to leave their homes and go into the wilderness. What does the Lord ask us to do to obey Him today?
- Help the children color and cut out the paper figures on this week’s activity page; then ask them to use the paper figures to summarize the account of Nephi and his brothers getting the brass plates (see 1 Nephi 3–4). The song “Nephi’s Courage” (*Children’s Songbook*, 120–21) and “Chapter 4: The Brass Plates” (*Book of Mormon Stories*, 8–12; see also the corresponding video on ChurchofJesusChrist.org) can help you tell this story.
- Use pictures 103–15 in the *Gospel Art Book* to help the children think of things the Lord has commanded us to do. How are we blessed when we obey Him? Help them decorate badges to wear that say *I will go and do the things which the Lord hath commanded* (1 Nephi 3:7). Repeat the phrase several times together.

1 NEPHI 3:19–21; 5:19–22

The scriptures are a great treasure.

How can you help inspire the children to treasure the scriptures, or the word of God?

Possible Activities

- Show the children something (or a picture of something) that is very valuable to you. Talk about how you treat it and take care of it. Explain that to Lehi’s family, the scriptures were very valuable, like a treasure.
- Invite the children to help you tell or act out what Nephi and his brothers did to obtain the brass plates: they traveled a long distance, gave

up their gold and silver, and hid in a cave to save their lives. Read 1 Nephi 5:21. Why were the scriptures so valuable to Lehi’s family? How can we treat the scriptures like a treasure?



Lehi Receiving the Brass Plates, by Clark Kelley Price



Teach the Doctrine:
Older Children

1 NEPHI 2:16, 19–20

I can have my own testimony.

What do you learn from Nephi’s example about gaining a testimony of your own? How can you help the children learn from his example?

Possible Activities

- Ask the children to search 1 Nephi 2:16, 19 to discover how Nephi gained a testimony of his father’s words. Invite them to write Nephi’s actions on blocks or other objects and then build something with the objects to represent how those things help us build a testimony.
- Tell the children how you gained your testimony of the gospel. Invite them to share similar experiences they have had, and encourage them to follow Nephi’s example to keep building their testimonies. How can having our own testimony help us?

1 NEPHI 3:1-8**I can respond with faith to the Lord's commands.**

Developing an attitude like Nephi's will help the children when the Lord asks them to do something that seems difficult.

Possible Activities

- Divide the class into two groups. Invite one group to read Laman and Lemuel's response to Lehi (see 1 Nephi 3:2-5) and the other group to read Nephi's response (see 1 Nephi 3:2-4, 7). Invite a child to pretend to be Lehi and to ask the other children to pretend to return to Jerusalem to get the brass plates. Invite each group to respond in their own words as if they were the people they read about. What are some things God has commanded us to do? How can we be like Nephi?
- Sing together a song about obedience, such as "Nephi's Courage" or "Keep the Commandments" (*Children's Songbook*, 120-21, 146-47), and ask the children to listen for phrases that teach how we should respond to the Lord.

1 NEPHI 3-4**The Holy Ghost will lead me as I seek to do the Lord's will.**

Nephi followed the Spirit, "not knowing beforehand the things which [he] should do" (1 Nephi 4:6). How can you help the children you teach seek the guidance of the Holy Ghost?

Possible Activities

- Invite the children to act out the story of Nephi and his brothers trying to get the brass plates (see 1 Nephi 3-4). Invite a child to read 1 Nephi 4:6, and ask the class to listen for what Nephi did that allowed them to succeed.
- Share with the children some examples of things God would want them to do, such as befriend someone at school who seems lonely, forgive a sibling, or tell the truth after making a mistake. Ask the children to share how the Holy Ghost might help them in those situations. How can we invite the Holy Ghost to help us obey God?

**Encourage Learning at Home**

Invite the children to share experiences with their families when they were blessed for keeping the commandments. Encourage them to ask their family members to share similar experiences.

Improving Our Teaching**Help young children learn from the scriptures.**

To help young children learn from the scriptures, focus on a single verse of scripture or even just a key phrase. You might invite the children to stand up or raise their hands when they hear that word or phrase. (See also *Teaching in the Savior's Way*, 21.)

God will help me keep His commandments (1 Nephi 2:2-4; 3-4).

Color and cut out the figures below. Use them to tell the story of Nephi and his brothers getting the brass plates from Laban.

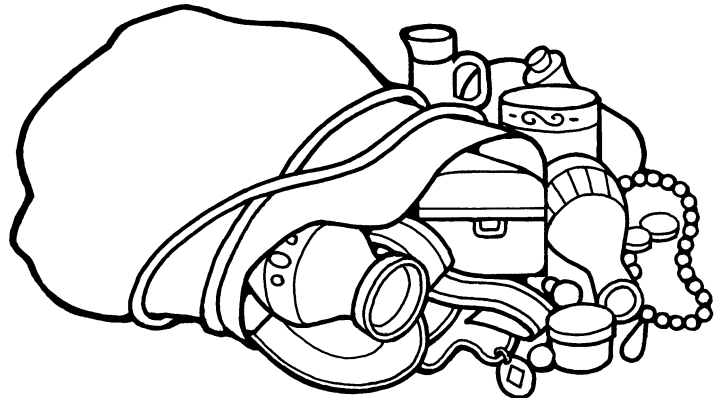
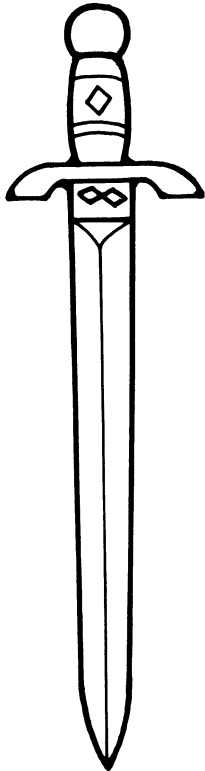
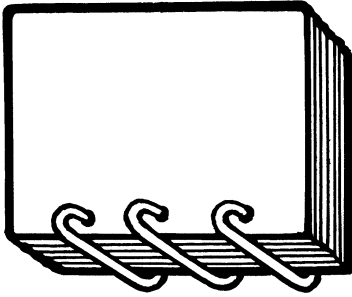



Lehi's Dream, by Steven Lloyd Neal

JANUARY 13–19

1 Nephi 8–10

“COME AND PARTAKE OF THE FRUIT”

In addition to seeing yourself in Lehi’s vision, try to see the children you teach. How does this vision apply to them?

RECORD YOUR IMPRESSIONS _____



Invite Sharing

Contact a few children in advance and ask them to think of experiences or scriptures they can share that have helped them feel God’s love.



Teach the Doctrine: Younger Children

1 NEPHI 8:2, 5–34

The word of God leads me to God and helps me feel His love.

In Lehi’s vision, we are invited to partake of the love of God, symbolized by the tree and its fruit. How can you help the children accept this invitation?

Possible Activities

- Invite the children to help you tell the story of Lehi’s vision from 1 Nephi 8:10–34. To help them visualize the story, you could show a picture of Lehi’s vision (see this week’s outline in *Come, Follow Me—For Individuals and Families*) or the pictures in “Chapter 6: Lehi’s Dream” (*Book of Mormon Stories*, 18–20, or the corresponding video on ChurchofJesusChrist.org). Make sure the children know that the rod of iron represents God’s word, which we read in the scriptures and hear from living prophets. Help them understand that the tree represents God’s love for us.
- Bring a rope to represent the iron rod in Lehi’s vision. Ask the children to hold on to it as you lead them around the room to a picture of a tree. Help them understand that God’s word brings us closer to Him, just as the rope representing the iron rod led us to the tree. To show that the tree represents God’s love, you could display pictures of things God has given us that show His love for us, such as the Savior, our families, and the beautiful world.

- Bring some fruit with a heart attached to it. Give the children a piece of the fruit to taste and ask them about their favorite fruits. Explain that the fruit in Lehi’s vision was the sweetest fruit he had ever tasted, and it filled his soul with joy. Just as sweet fruit makes us happy, we will feel happy when we follow Jesus and live with Heavenly Father again.
- Read 1 Nephi 8:12, and invite the children to listen carefully for what Lehi wanted to do after he tasted the fruit. Let the children take turns pretending to be Lehi inviting others to come and partake of the fruit. What can we do to invite others to come and enjoy the blessings of the gospel with us?

1 NEPHI 10:17, 19

God will reveal truth to me by the power of the Holy Ghost.

After hearing about his father’s vision, Nephi had a desire that we should all have—the desire to know the truth for himself.

Possible Activities

- Read 1 Nephi 10:19, and invite the children to raise their hands when they hear the words “unfolded” and “Holy Ghost.” Help the children understand this scripture, which teaches that the Holy Ghost will help us to know answers to our questions. To help the children visualize what it means for truth to be “unfolded,” bring a folded blanket with a picture of the Savior inside, and ask the children to unfold it.
- Sing a song with the children about seeking truth, such as “Search, Ponder, and Pray” (*Children’s Songbook*, 109). Show pictures that illustrate words in the song to help the children remember how the Holy Ghost teaches us.
- Consider sharing an experience when the Holy Ghost helped you know something was true. Tell the children how the Holy Ghost spoke to you.



Teach the Doctrine:
Older Children

1 NEPHI 8:2, 5-34

The word of God leads me to God and helps me feel His love.

As the children in your class learn about Lehi’s vision, encourage them to study God’s word and share God’s love with others.

Possible Activities

- As the children read selected verses from 1 Nephi 8, invite them to find details from these verses in a picture of Lehi’s vision (such as the one in this week’s outline in *Come, Follow Me—For Individuals and Families*). Or invite them to draw pictures on the board of the details they read about. Then help the children discover what the symbols in the dream represent (see 1 Nephi 11:21–22; 12:16–18; 15:23–33, 36).
- If possible, bring a piece of iron or other metal to class and invite the children to describe some of its properties and things it might be used for. How is the word of God like an iron rod? Where do we find the word of God? Why is the iron rod so important in Lehi’s vision?



Lehi eating the fruit of the tree of life. *Tree of Life*, by Marcus Alan Vincent

- Invite the children to write on a piece of paper an experience when the word of God helped them know what they should do or helped them feel closer to Heavenly Father. As they share what they wrote, invite them to roll their paper into the shape of a rod. You could even tape the children’s “rods” together as a representation of the iron rod in Lehi’s dream.
- Invite some of the children to read 1 Nephi 8:10–12 and describe what Lehi saw. Ask the others to read 1 Nephi 11:20–23 and describe what Nephi saw. Why would the angel show Nephi the baby Jesus to teach him about the love of God? To help answer this question, read together John 3:16 or sing together a song about the Savior, such as “He Sent His Son” (*Children’s Songbook*, 34–35). Tell the children how you have felt the love of Heavenly Father and His Son Jesus Christ in your life.
- Write on the board: *What do we learn from Lehi’s example?* Invite the children to think about Lehi’s vision and write as many answers as they can. Ask them to share their answers with the class. Then ask the children to think of someone they can share the joy of the gospel with.

1 NEPHI 10:17–19; 11:1

God will reveal truth to me by the power of the Holy Ghost.

If we ask Heavenly Father in faith, truth will be “unfolded unto [us] by the power of the Holy Ghost” (1 Nephi 10:19). How can you help the children you teach understand this truth?

Possible Activities

- Invite the children to talk about ways they can find answers to a question. Encourage the children to read 1 Nephi 10:17–19 and 11:1. What would Nephi say if someone asked him how to find answers to a question about the gospel? How does God teach us through the Holy Ghost? (see D&C 8:2).
- Ask the children to talk about a time when the Holy Ghost helped them know that something was true. Ask them to imagine they have a friend who thinks he or she can’t receive answers through the Holy Ghost. What could they share from 1 Nephi 10:17–19 and 11:1 to help that friend?



Encourage Learning at Home

Encourage the children to use this week’s activity page to share with their families what they learned about Lehi’s vision of the tree of life.

Improving Our Teaching

Children learn in many ways. Children enjoy learning through varied experiences. Use activities that help them move about, use all their senses, and try new things. (See *Teaching in the Savior’s Way*, 25–26.)

The word of God leads me to God and helps me feel His love (1 Nephi 8:2, 5-34).

Find your way through the maze of Lehi's vision, avoiding things that will prevent you from reaching the tree of life.

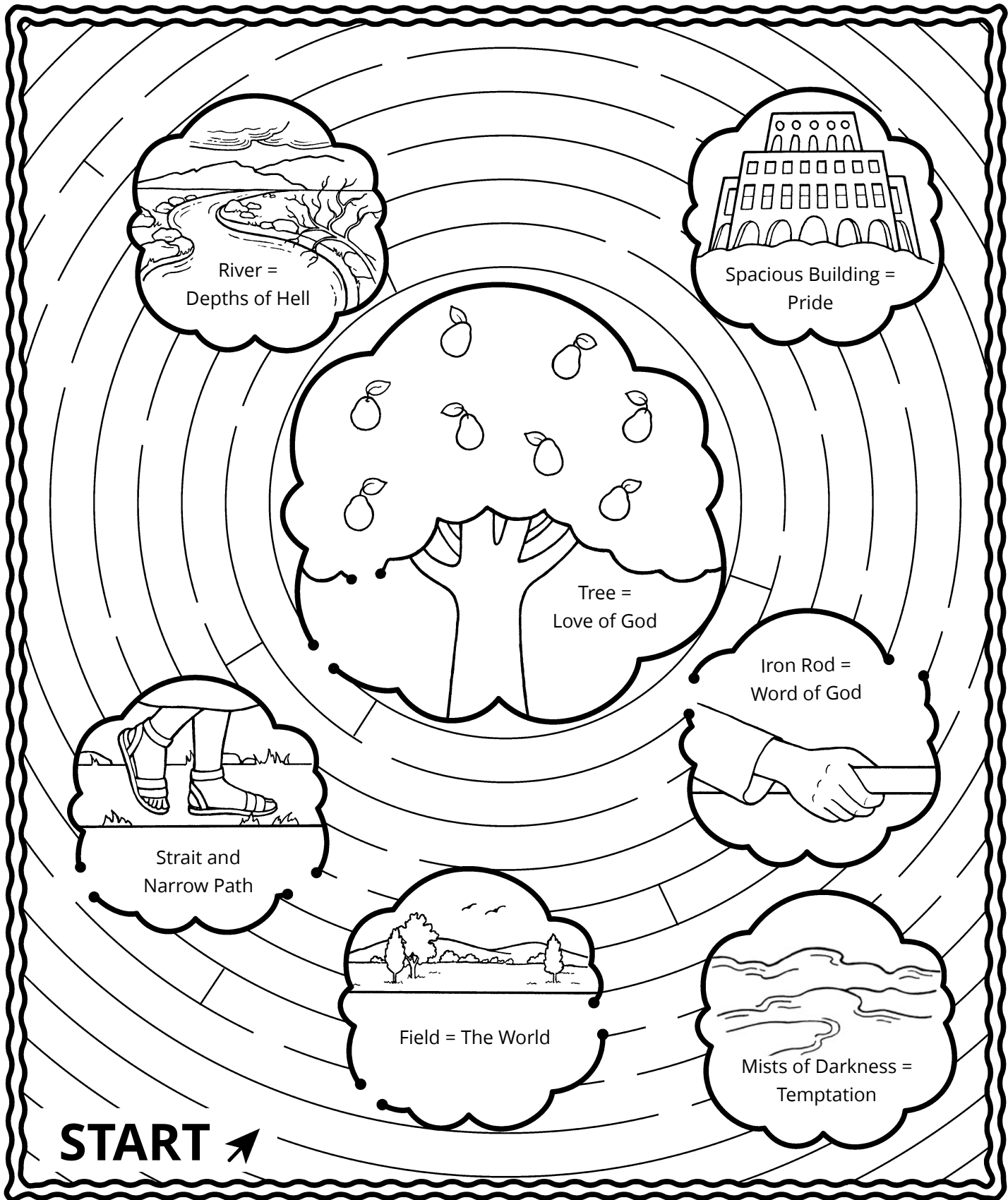



Sweeter Than All Sweetness by Miguel Ángel González Romero

JANUARY 20–26

1 Nephi 11–15

“ARMED WITH RIGHTEOUSNESS AND THE POWER OF GOD”

Read 1 Nephi 11–15 with the children you teach in mind, and record any impressions you receive.

RECORD YOUR IMPRESSIONS _____



Invite Sharing

Show a picture of Lehi’s vision of the tree of life, and invite the children to share what they remember learning about this vision last week. Ask them if they have learned anything new about it since then.



Teach the Doctrine: Younger Children

1 NEPHI 11:16–33

Heavenly Father sent Jesus Christ to earth because He loves me.

Nephi saw the life and ministry of Jesus Christ in a vision. Ponder what the children in your class could learn about the Savior from 1 Nephi 11.

Possible Activities

- Give each child a picture that illustrates one of the events from the Savior’s life foretold in 1 Nephi 11:20, 24, 27, 31, and 33 (see *Gospel Art Book*, nos. 30, 35, 39, 42, 57). As you read these verses, ask the children to hold up their picture when they hear the verse that matches it.
- Tell the children about some of the things Nephi learned that Jesus Christ would do during His life (see 1 Nephi 11:16–33), and show them pictures of some of these events (see, for instance, *Gospel Art Book*, nos. 41, 46, 47, 49, 56, 57, 58, 59). Share what the Savior has done for you. Show pictures to help the children think of ways we can share God’s love (see *Gospel Art Book*, nos. 109, 110, 115).

1 NEPHI 13:26–29, 35–36, 40

The Book of Mormon teaches precious truths.

Why are you grateful for the Book of Mormon? Consider how you might share your testimony of the Book of Mormon with the children.

Possible Activities

- Draw a picture on the board, and invite the children to change or remove parts of the picture to make it look different. Help them understand that, like this picture, some things in the Bible were changed and taken out over time. Read parts of 1 Nephi 13:40 that teach how the Book of Mormon (which Nephi calls “these last records”) helps us understand the “plain and precious things” that were lost from the Bible.
- Hide around the room pictures representing gospel truths that are clarified in the Book of Mormon, such as baptism, the sacrament, and resurrection. Invite the children to find these pictures. Explain that the Book of Mormon brought back gospel truths that had been lost.

1 NEPHI 15:23–25

The word of God gives me power.

How can you use the image of the iron rod to teach the children about the strength, security, and power of the word of God?

Possible Activities

- Display a picture of Lehi’s dream, like the one in last week’s outline in *Come, Follow Me—For Individuals and Families*. Invite the children to find the iron rod in the picture, and help them understand how holding to the word of God can protect us (see 1 Nephi 15:23–24). Give the children something similar to an iron rod to hold, such as a pipe or stick, while you read verse 24. Where do we find the word of God? What can we do to make the word of God part of our lives every day?
- Help the children color and complete this week’s activity page. How do we “hold fast” to the word of God? (1 Nephi 15:24).



Teach the Doctrine:
Older Children

1 NEPHI 11:16–33

Heavenly Father sent Jesus Christ to earth because He loves me.

Nephi had a vision in which he witnessed Heavenly Father’s plan for us, and Jesus Christ was a central part of that vision.

Possible Activities

- Invite the children to match verses from 1 Nephi 11:16–33 with pictures that depict what the verses describe (such as 1 Nephi 11:20, 24, 27, 29, 31, 33; see *Gospel Art Book*, nos. 30, 35, 38, 39, 42, 57). What do the children learn about Christ from the verses and pictures?
- Ask the children why Jesus Christ is important to them. Sing a song about the Savior, such as “He Sent His Son” (*Children’s Songbook*, 34–35), and ask the children what this song teaches about Jesus. Invite the children to make time during the week to think about Jesus Christ and share their experiences next week in class.



The Book of Mormon teaches us the gospel of Jesus Christ.

1 NEPHI 13:26–29, 35–36, 40**The Book of Mormon teaches precious truths.**

What do the children know about the Apostasy? How can you help them understand the importance of the Book of Mormon in restoring gospel truths that were lost during the Apostasy?

Possible Activities

- Read 1 Nephi 13:26–29 together, and invite the children to look for what happens when people do not have the “plain and precious” truths of the gospel. How did the Lord restore truths that had been lost? (see verses 35–36, 40). Invite the children to share their testimonies of truths they have learned from the Book of Mormon, or share your own.
- Show the video “The Book of Mormon—a Book from God” (ChurchofJesusChrist.org) to illustrate how the Bible and the Book of Mormon work together to teach truth. Why is it helpful to have more than one witness? Draw a dot on the board, label it *Bible*, and invite each child to draw a different straight line passing through the dot to illustrate that teachings in the Bible can be interpreted many ways when the Bible stands alone. Erase the lines, and draw a second dot labeled *Book of Mormon*. Invite a child to draw a straight line that passes through both dots to show that there is only one way to interpret the gospel when the Bible and Book of Mormon are used together.
- Help the children memorize the eighth article of faith.

1 NEPHI 15:23–25**The word of God gives me power to resist temptation.**

How can you help the children you teach strengthen their testimonies of the scriptures? Ponder this question while reading 1 Nephi 15:23–25, and use the activities below to supplement your own ideas.

Possible Activities

- Ask the children to summarize the vision of the tree of life (see 1 Nephi 8; 11). What kept people from reaching the tree? What helped them reach it? Invite the children to read 1 Nephi 15:23–25. How did the iron rod help the people get through the mists of darkness? How can reading the word of God help us resist temptation and darkness today?
- Complete the activity page with the children. While they are doing it, ask them to talk about some of the temptations children face. How can they remember to hold on to the iron rod every day? Sing “The Iron Rod” (*Hymns*, no. 274) as part of this activity.

**Encourage Learning at Home**

Encourage the children to show their families the “iron rods” they made from the activity page and share how they can hold to the iron rod by reading the scriptures.

Improving Our Teaching

Use art to engage learners. When you teach the children a scripture story, find ways to help them visualize it. You could use pictures, videos, puppets, costumes, and so on.

The word of God gives me power to resist temptation (1 Nephi 15:23-25).

Color the pictures that show different ways we can receive the word of God.

Tape a pencil to the top of the back side of this page, and roll it up tightly.

Tape the roll together to make an iron rod.

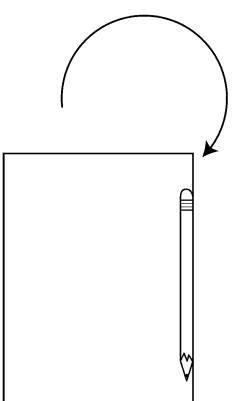

HOLD TO THE IRON ROD—THE WORD OF GOD!

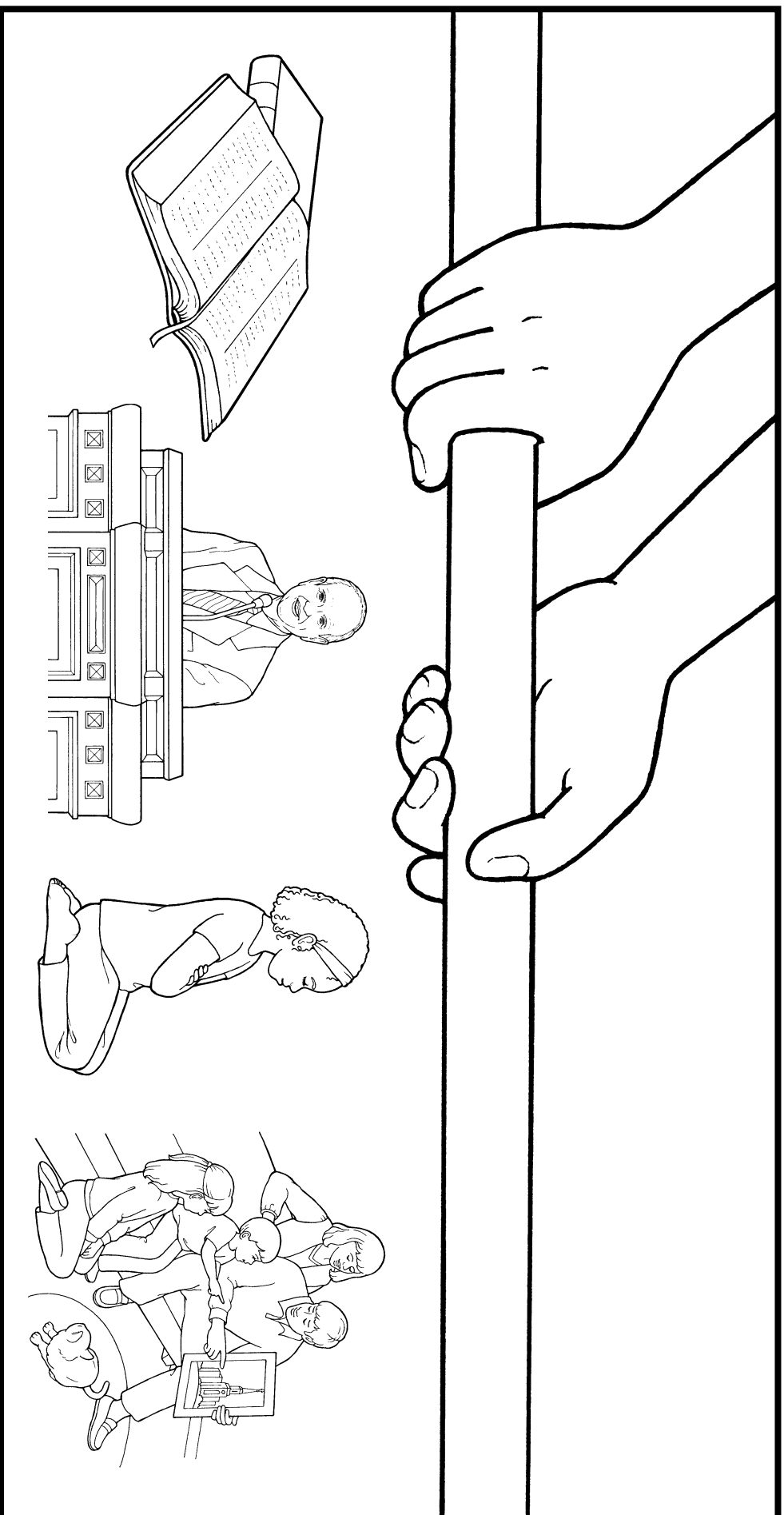

HOLD TO THE IRON ROD—THE WORD OF GOD!



Lehi and the Liahona, by Joseph Bruckey

JANUARY 27–FEBRUARY 2

1 Nephi 16–22

“I WILL PREPARE THE WAY BEFORE YOU”

The inspiring stories in 1 Nephi 16–22 teach truths that can bless the children in your class. Read these chapters and record impressions you receive.

RECORD YOUR IMPRESSIONS _____



Invite Sharing

Write the following words on the board, or show pictures of them: *the Liahona*, *the bow*, and *the boat*. Invite three children to each pick one of the words or pictures and share the part of Nephi’s story that features that object. Give help if needed.



Teach the Doctrine: Younger Children

1 NEPHI 16:10, 28–29; 18:8–13, 20–22

The Lord can guide and direct me.

Teach the children that even when they face difficult challenges, the Lord can guide them (see 1 Nephi 16:29).

Possible Activities

- Show the children a compass, a map, or something else that helps us find our way, and explain how to use these tools. Compare these tools to the Liahona as you summarize the story in 1 Nephi 16:10, 28–29 and 18:9–13, 20–22. Point out that when Lehi’s family was not obedient, the Liahona did not work (see also 1 Nephi 18:9–12, 20–22). What helps us today to find our way back to Heavenly Father?
- Bring a box containing several clues that describe a location in or around the church building. Use

the box and clues to represent the Liahona, and let the children take turns selecting clues and guessing what the location is. Then travel to the location together. Explain that when we show faith and follow the direction the Lord gives us, He will help us return to Him (see Alma 37:38–42). How does Heavenly Father guide us in our journey back to Him?

1 NEPHI 16:14–32

I can be a good example to my family.

Nephi’s interactions with his family during a difficult time can help the children see that even though they are young, they can be examples to their families.

Possible Activities

- Assign each child to draw a picture of something from the story of Nephi’s broken bow (see 1 Nephi 16:14–32), such as Nephi, a bow, or the Liahona. Then use the pictures to tell the story to the class, and let the children take turns doing the same. How can we be like Nephi when our families are going through hard times?
- Invite the children to each cut out a paper circle and draw a sad face on one side and a happy face on another. As you tell the story of Nephi’s broken bow, invite them to use the faces to show how Nephi’s family was feeling during different parts of the story. How did Nephi help make his family happy? What can we do to make our families happy?

1 NEPHI 17:7–19; 18:1–4

Heavenly Father can help me do difficult things.

Like Nephi, the children you teach are learning to do things that seem hard. Nephi’s experience can help them know that Heavenly Father will help them when they ask.

Possible Activities

- Tell the children the story of Nephi being commanded to build a boat, using 1 Nephi 17:7–19 and 18:1–4. You might also use “Chapter 7: Building the Ship” (*Book of Mormon Stories*, 21–22) or related videos in the Book of Mormon Videos collection on ChurchofJesusChrist.org. This week’s activity page can reinforce the principle that Heavenly Father helped Nephi, and He will help us.
- Sing together the second verse of “Nephi’s Courage” (*Children’s Songbook*, 120–21). What helped Nephi have courage when his brothers mocked him for trying to build the boat?



**Teach the Doctrine:
Older Children**

1 NEPHI 16:10, 28–29; 17:13–15; 18:8–13, 20–22

**When I keep the commandments,
the Lord guides me.**

Use the account of Lehi’s family being guided by the Liahona to show the children how God will guide them as they strive to do His will.

Possible Activities

- Select one or more of the following passages to read with the children: 1 Nephi 16:10, 28–29; 17:13–15; and 18:8–13, 20–22. Ask them to look for what we must do to get guidance and direction from God and discuss what they learn.
- After reviewing the stories in 1 Nephi 16–18, interview several children as if they had traveled with Lehi’s family. You could ask questions like these: Why were you grateful for the Liahona? What did you need to do so that the Liahona would work? (see 1 Nephi 16:28–29). Invite the

class to discuss things the Lord has provided to guide us in our day.

- Ask the children to consider how they might use the story of the Liahona to help a friend who needs to make an important decision. Suggest that in addition to 1 Nephi 16:10, 26–31 and 18:9–22, they could also refer to Alma 37:38–44. Share an experience in which Heavenly Father helped you through a difficult time, or invite the children to share one. What must we do to receive His help?

1 NEPHI 16:14–39; 18:1–5

My attitude and choices can have a good influence on my family.

Nephi’s faith was a great blessing when his family faced trials. How can you help the children learn from his example?

Possible Activities

- Invite the children to draw pictures depicting the story of Nephi’s broken bow (see 1 Nephi 16:14–39). Review the story with them, if needed. As they share their drawings, help them identify ways in which Nephi’s faithfulness blessed his family. Invite the children to ponder challenges they or their families are facing. What can they do to follow Nephi’s example?
- Read together some verses from 1 Nephi 16:21–32. Discuss some goals the children’s families might have, such as having regular family home evenings or family prayer. How can the children help their families achieve these goals? Invite them to plan to do one thing to help their families meet their goals this week.

1 NEPHI 19:22–24

I can liken the scriptures to my life.

Help the children see that the accounts in the scriptures are more than stories—they contain principles that can bless their lives.

Possible Activities

- Ask a child to read 1 Nephi 19:22–24 out loud, and ask the children what they think it means to “liken all scriptures” to ourselves. Help them discover how Nephi likened a scriptural account to his experience of getting the brass plates (see 1 Nephi 4:1–4; see also Exodus 14). How did remembering this story help Nephi and his brothers?
- Review some of the stories that the children have learned about Lehi and his family from 1 Nephi, and invite them to share what they learned from these stories. Help them think of situations in their lives that might be similar to these stories. For example, the Lord asking Nephi to build a ship might remind them of times when they needed to do something difficult and sought the Lord’s help.



Encourage Learning at Home

Invite the children to choose a story from 1 Nephi 16–22 and share with their families how they can “liken” that story to their life.

Improving Our Teaching

Use stories. Stories help children understand gospel principles because they demonstrate how others live those principles.

Heavenly Father can help me do difficult things (1 Nephi 17:7-19, 18:11-21).

Make a pop-up boat by first coloring the pictures and then cutting out the rectangle and the boat. Fold the rectangle in half on the dotted line. Fold the dotted lines on the bottom part of the boat, and glue the marked tab to the back of the boat, as illustrated. Glue the boat to the rectangle by matching the numbered sections.

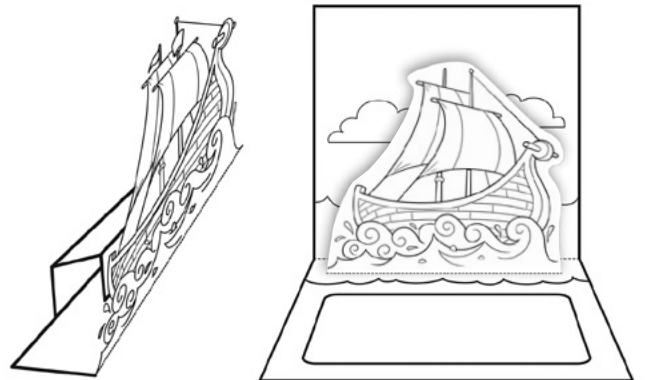
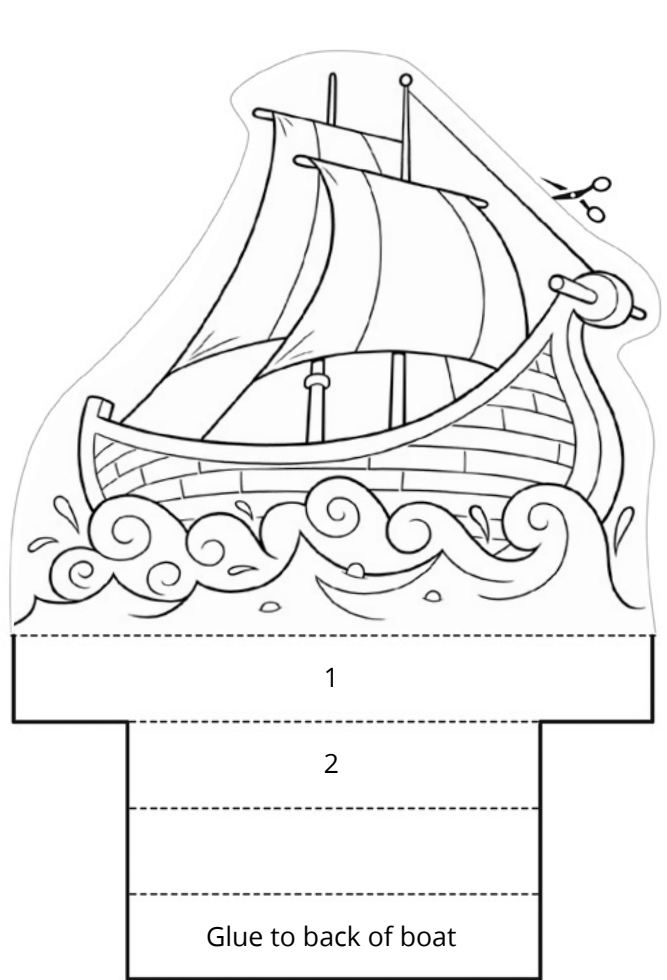
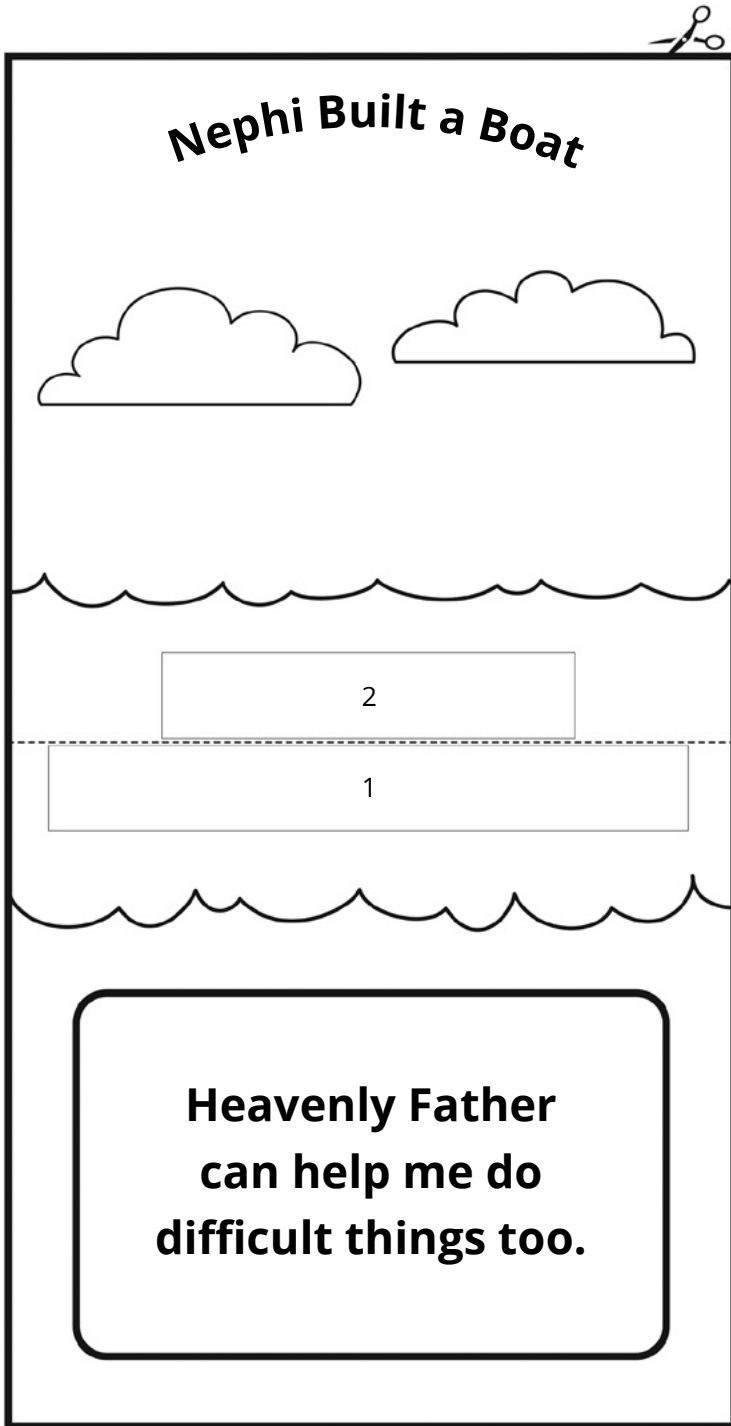



Adam and Eve, by Douglas Fryer

FEBRUARY 3-9

2 Nephi 1-5

“WE LIVED AFTER THE MANNER OF HAPPINESS”

Lehi taught each of his children according to their individual needs and circumstances. Follow his example as you prepare to teach the children in your class.

RECORD YOUR IMPRESSIONS _____



Invite Sharing

After explaining that Lehi taught his family about freedom to make our own choices, invite children to share experiences they have had choosing the right. How did they feel after they made that choice? How can they remember to choose the right in the future?



Teach the Doctrine: Younger Children

2 NEPHI 1:20

I am blessed when I obey.

The principle taught in this verse—obedience brings blessings—is illustrated often throughout the Book

of Mormon. Consider how you can help the children recognize it in their own lives.

Possible Activities

- Ask the children to help you define the word *commandments* and make a list of commandments. Read 2 Nephi 1:20, and emphasize that we will “prosper,” or be blessed, when we keep the commandments. How do we feel when we keep these commandments?
- Show the children things that offer protection, such as shoes, hats, and gloves. Let them try them on. How do these things protect us? Tell them that Heavenly Father’s commandments can protect us from spiritual danger. Share an experience when you were protected by following the commandments.

2 NEPHI 2:11, 16, 27

God gave me the freedom to choose.

Because of their choices, Adam and Eve had to leave the Garden of Eden. How can you teach the

children that Adam and Eve’s choice allows us to use our agency to choose Heavenly Father today?

Possible Activities

- Draw a picture of a free person and a picture of a captive person (perhaps a person in jail), and invite the children to point at the correct picture when you read the words *free* and *captivity* in 2 Nephi 2:27. Emphasize the phrase “free to choose,” and invite each child to repeat it.
- Review with the children the story of Adam and Eve (see 2 Nephi 2:17–19; see also “Chapter 3: Adam and Eve,” *Old Testament Stories*, 15–18, or the corresponding video on ChurchofJesusChrist.org) and the choice they made in the Garden of Eden. Help the children list some choices they make every day. Testify that our Heavenly Father gave us freedom to choose between good and evil, and invite the children to jump up and down or clap their hands to celebrate being free to choose.
- Play a game in which you say a word (such as *light*) and the children say its opposite (*dark*). Repeat this activity several times. To help the children understand how having opposites helps us make choices, read the first half of 2 Nephi 2:11 and 2 Nephi 2:16. Tell the children stories about a child who is tempted to make a wrong choice. Help the children think of what the opposite of that choice is, and invite them to act it out. Testify that Heavenly Father blesses us when we choose the right.
- Sing together a song about making choices, such as “I’m Trying to Be like Jesus” or “Choose the Right Way” (*Children’s Songbook*, 78–79, 160–61), and ask the children what they learn from the song about making choices.



Teach the Doctrine: Older Children

2 NEPHI 1:20

I am blessed when I obey.

When children have faith that God will bless them for keeping the commandments—even if those blessings do not come right away—it is easier for them to make righteous choices.

Possible Activities

- Help the children review some of the choices that Nephi and his brothers made. For some examples, see 1 Nephi 2:11–16; 3:5–7; and 18:9–11. Invite them to read 2 Nephi 1:20 together and share why they think Lehi would give this message to his children.
- Write phrases from 2 Nephi 1:20 on strips of paper, and discuss what the phrases mean. Invite the children to put the strips in the correct order using the verse. To illustrate the difference between prospering and being cut off, show the children a healthy plant and a leaf or branch that has been cut off from the plant. What is the difference between a leaf that is on the plant and one that has been cut off? How are we like the leaf on the plant when we obey God’s commandments? Invite the children to record in a journal ways God blesses them when they choose the right.

2 NEPHI 2:22-28**God gave me freedom to choose.**

Jesus Christ saved us from physical death and spiritual death (separation from God because of sin) through His Atonement and Resurrection. In order to live with Heavenly Father again, we must use our agency to continually repent and strive to live righteously.

Possible Activities

- Hold up a picture of Adam and Eve (see *Gospel Art Book*, no. 4), and invite the children to share what they know about what happened to Adam and Eve in the Garden of Eden. Help the children find answers in 2 Nephi 2:22–27. Explain that because of Adam and Eve’s choice, we are blessed to come to earth and use our agency to make good choices and repent through Christ’s Atonement when we make wrong choices.
- Write the words of 2 Nephi 2:27 on the board. Help the children memorize the verse by repeating it and taking turns erasing words every time they repeat it. Help the children imagine what a life without choices would be like. Why are they grateful for agency?
- Invite the children to share an experience when they made a good choice. How did they feel after they made that choice? What can we do to help ourselves choose the right when we are tempted to do something wrong? Consider singing a song about making choices, such as “Choose the Right” (*Hymns*, no. 239), and invite the children to share what they learn from the song.

2 NEPHI 3:6-24**Joseph Smith was a “choice seer.”**

In 2 Nephi 3, Lehi referred to a prophecy about the Prophet Joseph Smith. You can use this as an opportunity to teach the children about his mission in the latter days.

Possible Activities

- Invite the children to search 2 Nephi 3:6–24 for clues about which prophet is being spoken of. List the clues on the board. Why is Joseph Smith called a “choice seer”? What did Joseph Smith do that is “of great worth to [his brethren]”? (verse 7).
- Sing a hymn about Joseph Smith, such as “Praise to the Man” (*Hymns*, no. 27), or watch a video that depicts different aspects of his mission, such as those found at history.ChurchofJesusChrist.org/article/joseph-smith-video-downloads. Ask the children why they are grateful for the Prophet Joseph Smith.

**Encourage Learning at Home**

Encourage the children to notice opportunities they have to make choices this week. Invite them to be ready to share next week what choices they made and the results of their choices.

Improving Our Teaching**Children can recognize the Spirit’s influence.**

Teach the children that the feelings of peace, love, and warmth they have when they talk or sing about Jesus Christ and His gospel come from the Holy Ghost. These feelings can build their testimonies.

Eve



**God gave me
freedom to choose
(2 Nephi 2:22-27).**

Cut out the rectangle
on the solid black line.
To make a booklet,
fold along the dotted lines.

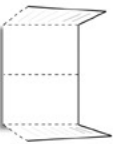
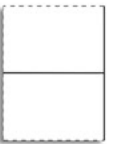
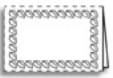

Fold 1

Other ways I am like
Adam and Eve:

Fold 2

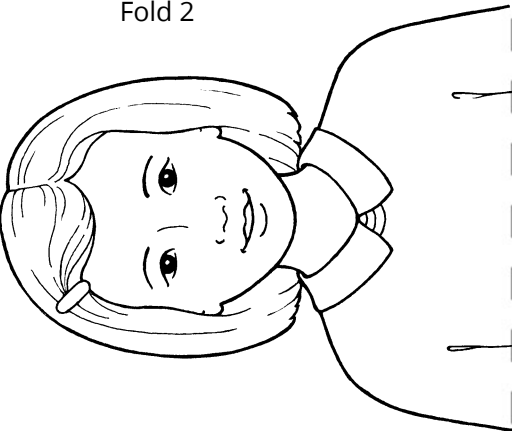

Fold 4

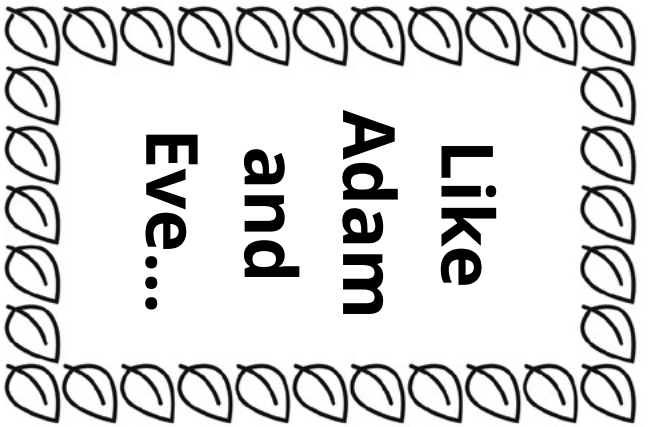
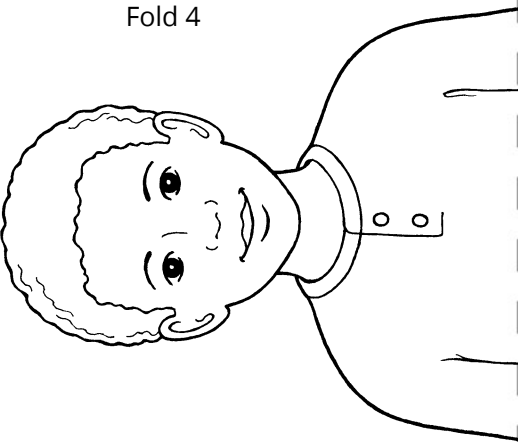

Adam

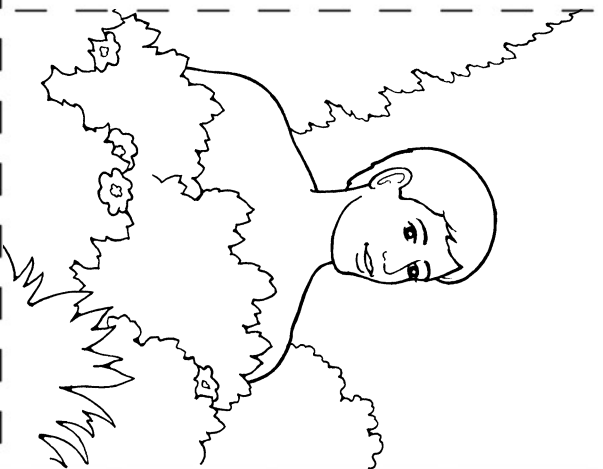

- I have agency.
- I am a child of God.
- I can have joy.
- I came to earth.
- I can learn to know good from evil.

Fold 3





Not My Will, But Thine, Be Done, by Harry Anderson

FEBRUARY 10-16

2 Nephi 6-10

“O HOW GREAT THE PLAN OF OUR GOD!”

As you read 2 Nephi 6-10, seek guidance from the Spirit about what to teach. This outline and *Come, Follow Me—For Individuals and Families* may inspire additional ideas.

RECORD YOUR IMPRESSIONS _____



Invite Sharing

Encourage the children to take turns sharing something they learned about Jesus Christ and His Atonement while studying 2 Nephi 6-10 individually or with their families.



Teach the Doctrine: Younger Children

2 NEPHI 9:7-13, 20-23

Jesus Christ saves me from sin and death.

How can you use 2 Nephi 9:7-13 and 20-23 to help the children understand that Jesus Christ saves everyone from death and makes it possible for us to repent from sin?

Possible Activities

- Tell the children a story of a person who fell into a pit so deep that he or she could not climb out. A man came along and lifted this person out of the pit. You may want to draw a picture of this story on the board or act it out with the children. Explain that this pit is like death and the man who helped the person is like Jesus Christ, who saved all people from death by giving us the gift of resurrection. Tell the children that this same person fell into another pit. This time the rescuer gave the person a ladder to use in climbing out of the pit. Explain that this pit is like sin and the ladder is the Atonement of Jesus Christ, which allows us to repent and be forgiven of our sins. Read 2 Nephi 9:22-23, and bear your testimony of Jesus Christ and His Atonement.
- Sing together a song about the love of Jesus Christ, such as “I Feel My Savior’s Love” (*Children’s Songbook*, 74-75). Invite the children to draw pictures of things that help them know the Savior loves them.

2 NEPHI 9:49

“My heart delighteth in righteousness.”

How can you encourage the children you teach to “[delight] in righteousness,” or joyfully obey the Lord? (2 Nephi 9:49).

Possible Activities

- Read 2 Nephi 9:49 to the children, and help them find and understand what Jacob said that he loves and hates. Share scenarios in which a child makes a good choice or a bad choice, and invite the children to stand up when the choice brings happiness and sit down when the choice brings sadness. Why does choosing the right bring us joy? When have you felt happy because you made the right choice?
- Sing together a song about the joy that comes from obedience, such as “When We’re Helping” (*Children’s Songbook*, 198), and ask the children to listen for what makes us happy. Let the children take turns pretending to be a parent asking the other children to do something. Have the other children practice obeying joyfully.



Teach the Doctrine:
Older Children

2 NEPHI 6; 7:1-2

The Lord will always fulfill His promises.

Understanding that the Lord keeps His promises can help the children build their faith in Him and their confidence in obeying His commandments.

Possible Activities

- Ask the children to talk about some promises they have made, such as a promise they made to a friend or the covenants they made at baptism. Why is it sometimes difficult to keep our

promises? Why is it important to keep our promises? Read the following phrase: “The Lord God will fulfil his covenants which he has made unto his children” (2 Nephi 6:12). Share an example of how God kept His promises, even if the blessings did not come right away.

- Display a picture of Jesus next to a picture of a child. Read 2 Nephi 7:1, and explain that when God’s people stop obeying His gospel, it’s like they have “divorced” Him. Move the picture of the child away from the picture of Jesus to show that when we don’t keep our covenants, such as the covenant of baptism, we separate ourselves from Heavenly Father and the Savior. (To review the covenants of baptism, see D&C 20:37.) How does the Savior’s Atonement allow us to move back closer to Him? As you discuss this, invite the children to move the pictures close together again.

2 NEPHI 9:10-23

Jesus Christ saves me from sin and death.

How can you use 2 Nephi 9:10–23 to help the children learn that Jesus Christ is their Savior?

Possible Activities

- Ask the children to help you draw a path on the board, and invite them to add some obstacles or roadblocks along the path. Read together 2 Nephi 9:10, and invite the children to label the obstacles on the path with words from this verse that describe obstacles that could keep us from returning to God. Then talk about how Jesus Christ overcame these obstacles for us (see 2 Nephi 9:21–23), and as you do, invite the children to erase the obstacles.
- Show a picture of Adam and Eve, such as *Leaving the Garden of Eden* (ChurchofJesusChrist.org). Explain that when Adam and Eve ate the fruit that God told them not to eat in the Garden of Eden, they brought sin and death into the world. Show a

picture of Jesus Christ. To help the children understand how Jesus overcame sin and death, tell the story of the person who fell into a pit, found in the first teaching idea under “Younger Children” in this outline. Then ask the children to draw pictures of this story or act it out. Read 2 Nephi 9:21–23, and bear your testimony of Jesus Christ and His Atonement.

- Help each child find a song about the Savior’s Atonement in either the hymnbook or the *Children’s Songbook* (the indexes in these books can help). Invite the children to find and share phrases from the song that describe what Jesus did for us. Ask the children to share their thoughts and feelings about the Savior’s Atonement, or share your testimony.

2 NEPHI 9:20, 28–29, 42–43

I will be blessed as I follow God’s counsel.

Help the children build a strong foundation of trust in God so that as their knowledge and abilities increase, they will continue to rely on Him and follow His counsels.

Possible Activities

- Invite the children to tell you about something they know a lot about, such as a favorite book or hobby. Ask a child to read 2 Nephi 9:20, and testify

that God “[knows] all things.” Why is it important for us to understand that God knows everything?

- Ask the children to imagine that they heard a friend say that the commandments or teachings of the Church are foolish. What would they say to their friend? Why is it important to trust God’s counsel even if we do not completely understand it? Encourage the children to look in 2 Nephi 9:20, 28–29, and 42–43 for help with pondering and discussing these questions.



Encourage Learning at Home

Help the children think of a way they can teach their families what they have learned about Jesus Christ and His Atonement. For example, they might use this week’s activity page to explain how the Savior helps us overcome sin and death.

Improving Our Teaching

Use activity pages. As the children work on activity pages, use the time to help them see how the activity relates to the principles from the lesson and how the principles apply to their lives.

**Jesus Christ saves me from sin and death
(2 Nephi 9:7-13, 20-23).**

Cut out the ladder and the man on the dotted lines.
Use this page to tell the story of the man who fell into
a pit representing sin and death. Use the ladder
to represent how the Savior's Atonement helped
the man out of the pit. Because of Jesus Christ,
we can overcome sin and will be
resurrected after we die.

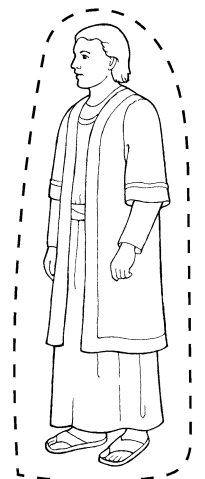
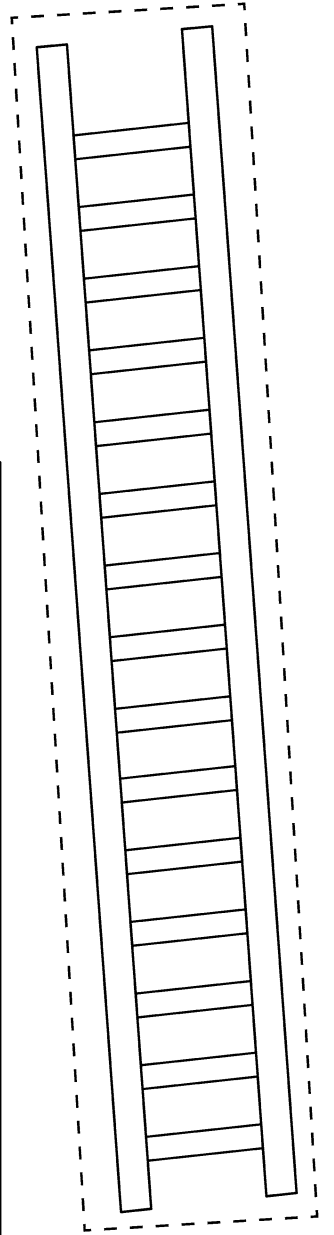
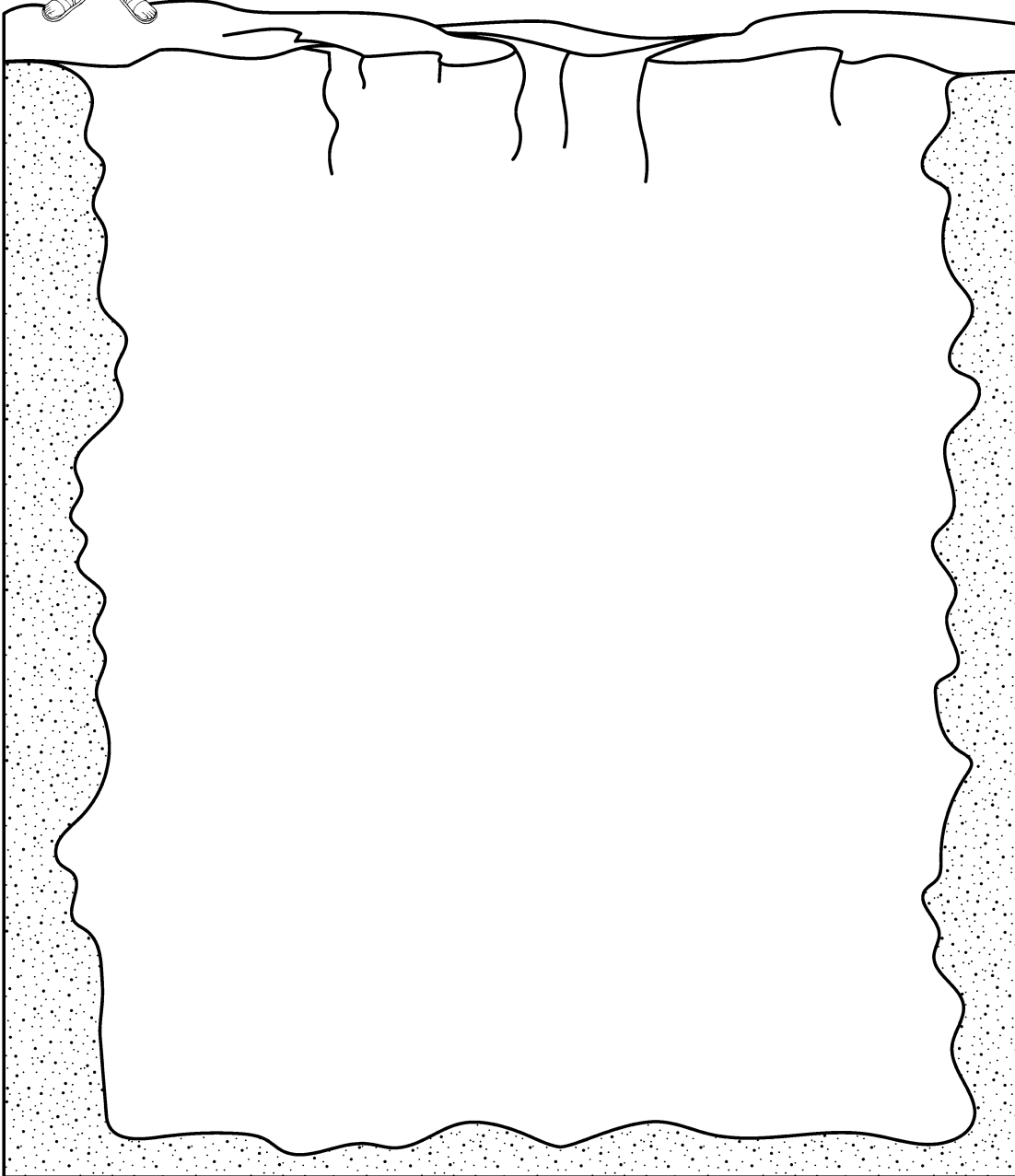
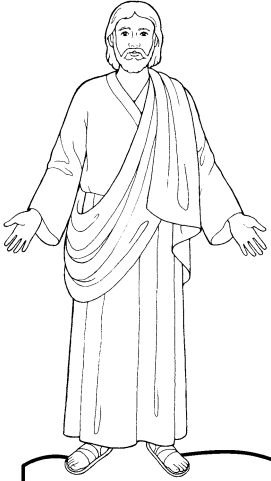



FEBRUARY 17-23

2 Nephi 11-25

"WE REJOICE IN CHRIST"

Your preparation to teach begins as you read 2 Nephi 11–25. *Come, Follow Me—For Individuals and Families* can help you understand these chapters, and this outline can give you teaching ideas.

RECORD YOUR IMPRESSIONS _____



Invite Sharing

Briefly review with the children what they learned about the Savior and His Atonement last week. If they shared what they learned with their families, encourage them to talk about that.



Teach the Doctrine: Younger Children

2 NEPHI 12:2-3

The temple is the house of the Lord.

Isaiah's prophecy about "the mountain of the Lord's house" could be an opportunity to teach the children about the temple and help them look forward to going there someday.

Possible Activities

- Let a child hold a picture of a temple (this week's outline in *Come, Follow Me—For Individuals and Families* has one), and ask the children to share what they know about the temple. Read 2 Nephi 12:3, and explain that in this verse a prophet named Isaiah prophesied that there would be temples in the last days. Read the verse again, and emphasize that when we go to the temple, the Lord "will teach us of his ways" and help us "walk in his paths."
- Make a path on the floor, and at the end of the path, place a picture of the temple with a covering over the picture. Let the children walk on the path, and as they do, help them repeat the phrase "walk in his paths." When the children reach the end of the path, let them uncover the picture. What does it mean to walk in God's paths?
- Sing with the children a song about the temple, such as "I Love to See the Temple" (*Children's Songbook*, 95). Help them find words and phrases in the song that teach what the temple is and what we do there.

2 NEPHI 19:6; 25:26**“We rejoice in Christ.”**

Nephi and Isaiah had testimonies of the Savior, and their testimonies made them joyful. Help the children see that you “rejoice in Christ.”

Possible Activities

- Invite a child to hold a picture of the birth of Jesus Christ (such as *Gospel Art Book*, no. 30), and help the children find the baby Jesus in the picture. Read 2 Nephi 19:6 or show the video “A Savior Is Born—Christmas Video” (ChurchofJesusChrist.org), and ask the children to point to Jesus when they hear the words *child* and *son*. Explain that the prophet Isaiah, who wrote the words in 2 Nephi 19:6, knew about the birth of Jesus hundreds of years before it happened.
- Tell a story about Jesus Christ bringing joy to others, or show a video such as “Jesus Heals a Man Born Blind” or “Suffer the Little Children to Come unto Me” (ChurchofJesusChrist.org). Point out joyful moments in the story or video. Read 2 Nephi 25:26 and talk about why you “rejoice in Christ.” Ask the children to talk about how Jesus brings them joy.

2 NEPHI 21:6–9; 22**The Millennium will be a time of peace and joy.**

After His Second Coming, Jesus Christ will dwell with His people during a period of peace called the Millennium.

Possible Activities

- Show the children pictures of animals mentioned in 2 Nephi 21:6–7, and ask the children to name the animals. Explain that these animals are usually enemies, but Isaiah taught that after Jesus Christ comes again, there will be a time of peace, called the Millennium, when animals will not hurt each

other. How can we follow the example of these animals in the way we treat each other? Invite the children to draw pictures of these animals living peacefully together.

- Read 2 Nephi 22:5, and ask the children to help you find a song that describes the “excellent things” the Lord has done. Some examples might include “My Heavenly Father Loves Me” (*Children’s Songbook*, 228–29) or “How Great Thou Art” (*Hymns*, no. 86). Sing the song together. Explain that in the Millennium, everyone will know about the “excellent things” the Lord has done.

**Teach the Doctrine:
Older Children****2 NEPHI 12:2–3****The temple is the house of the Lord.**

How can you use these verses to help the children look forward to the day when they can attend the temple?

Possible Activities

- Show a picture of a temple (this week’s outline in *Come, Follow Me—For Individuals and Families* has one). Ask a child to read 2 Nephi 12:2–3, and invite the other children to listen for reasons why Isaiah said we need temples. You could explain that Isaiah called the temple “the mountain of the Lord’s house.” Why is a mountain a good symbol for the temple?
- Invite the children to draw a picture of themselves going to the temple. If possible, ask one of the young men or young women in the ward to tell the children what it’s like to perform baptisms for the dead in the temple. This young

person or someone else in the ward could teach the children how to find the names of their ancestors who need temple ordinances.

2 NEPHI 15:20

Satan tries to confuse me about good and evil.

We live in a world where, as Isaiah prophesied, people call evil good and good evil. How can you help the children identify such deception?

Possible Activities

- Show the children something bitter or sour, such as a pickle or lemon, inside a candy wrapper. Read together 2 Nephi 15:20, and explain that Satan tries to make things that are evil look good. Help the children think of ways in which Satan does this. How can we detect his deceptions?
- Show the first minute and a half of the video “You Will Be Freed” (ChurchofJesusChrist.org). Why does the fisherman disguise his hook? Why does Satan disguise sin?

2 NEPHI 17:14; 19:6; 25:23–26

“We rejoice in Christ.”

Children need to know that the gospel of Jesus Christ is joyful. How will you help them “rejoice in Christ”?

Possible Activities

- Help the children find the names of Jesus Christ in 2 Nephi 17:14 and 19:6. You may need to

explain that “Immanuel” is one of these names, and it means “God with us.” What do each of these names teach us about Him?

- Put a picture of the Savior on the board, and read together 2 Nephi 25:26. Why did Nephi talk and write so much about Jesus Christ? Let each of the children write on the board, near the picture of Jesus, one thing about the Savior that brings them joy.
- Ask the children to think of someone they would like to “persuade . . . to believe in Christ” (2 Nephi 25:23). How can we express to others the joy that the Savior brings into our lives? Let the children write or role-play some things they might do to help the person they thought of believe in Jesus Christ.



Encourage Learning at Home

Invite the children to think of one thing they can do to show their families that they “rejoice in Christ.”

Improving Our Teaching

Let the children be creative. “As you teach children, allow them to build, draw, color, write, and create. These things are more than fun activities—they are essential to learning” (*Teaching in the Savior’s Way*, 25).

The temple is the house of the Lord (2 Nephi 12:2-3).

Cut out the windows with the names of ordinances that are performed in the temple, and match them with the pictures inside the windows of the temple. Make slits on the dotted lines, and insert the tab.

Fasten the tabs to the back with tape or glue so you can open the windows.

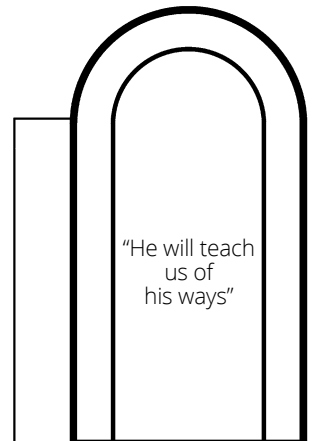
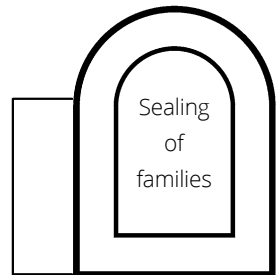
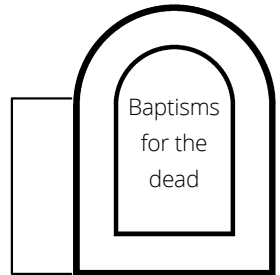
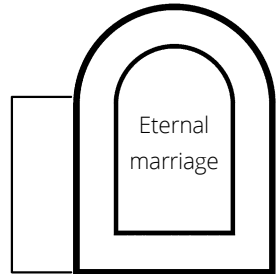
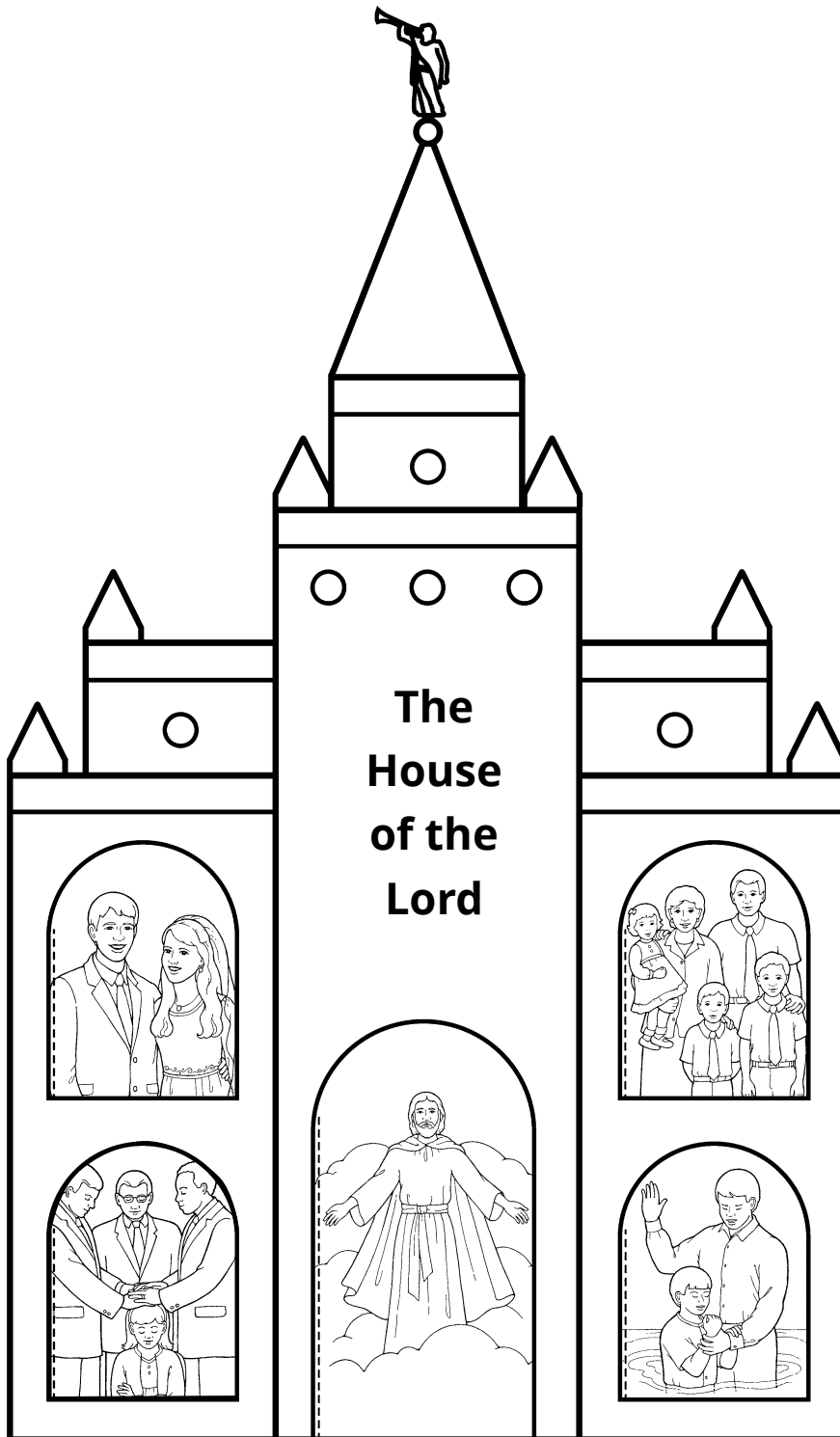



He Will Lead Thee by the Hand, by Sandra Raast

FEBRUARY 24–MARCH 1

2 Nephi 26–30

“A MARVELOUS WORK AND A WONDER”

Before you start planning learning activities for the children in your class, study 2 Nephi 26–30. This will invite the Spirit to guide your planning.

RECORD YOUR IMPRESSIONS _____



Invite Sharing

Hold up a copy of the Book of Mormon, and explain that Nephi foresaw that the Book of Mormon would be important in our day. Ask the children to share something they have learned about the Book of Mormon this year.



Teach the Doctrine: Younger Children

2 NEPHI 26:33

Jesus Christ wants everyone to come unto Him.

Nephi testified that the Savior loves everyone, no matter who they are, and He invites them all to “partake of his goodness.”

Possible Activities

- Display pictures of people from various ethnic and cultural backgrounds (you may find some in Church magazines). Ask the children to describe some of the details they see in the pictures. Open the scriptures to 2 Nephi 26:33 and read, “[Jesus Christ] inviteth them all to come unto him.” Repeat this phrase with the children as you point to each picture. Then point to each child and say, “Jesus Christ invites you to come unto Him.” What can we do to come unto the Savior?
- Sing a song with the children about loving all people, such as “I’ll Walk with You” or “We Are Different” (*Children’s Songbook*, 140–41, 263). Point out words or phrases in the song that you feel reinforce the message of 2 Nephi 26:33.

2 NEPHI 28:2; 30:6

The Book of Mormon is a blessing.

Consider how you will help the children in your class feel that the Book of Mormon is “a blessing unto them from the hand of God” (2 Nephi 30:6).

Possible Activities

- Show the children a Book of Mormon wrapped as a gift, and tell them that something valuable is inside. Let them hold the gift, and give clues to help them guess what it is; for example, it’s something the Lord has given us, it helps us believe in Jesus Christ, and so on. Read from 2 Nephi 30:6: “It is a blessing unto them from the hand of God.” Let the children open the gift, and then explain that we must open the Book of Mormon and read it to receive the blessings it contains.
- Read 2 Nephi 28:2 to the children. Explain that Nephi saw that the Book of Mormon would “be of great worth” to us, which means that it will help and bless us. Tell the children why the Book of Mormon is of great worth to you. Share your favorite verse or story from the Book of Mormon, and invite the children to share theirs. Show pictures from the *Gospel Art Book* to give them ideas.

2 NEPHI 28:30

Heavenly Father teaches me little by little.

Perhaps you can think of an object lesson or activity that will help the children see what it means to learn “line upon line.” The suggestions below may spark some ideas.

Possible Activities

- Help the children put together a simple puzzle or build something with blocks. Give them one puzzle piece or one block at a time, and while they are building, explain that this is the way Heavenly Father teaches us—one truth at a time. What would happen if we tried to put all of the pieces together at once?
- Teach the children a skill step by step, such as tying a bow or drawing a picture. Read from 2 Nephi 28:30: “I will give unto the children of men line upon line, . . . here a little and there a little.” Why does God teach us little by little?



Teach the Doctrine:
Older Children

2 NEPHI 26:23–28, 33

Jesus Christ wants everyone to come unto Him.

Help the children feel that the invitation to come unto Christ is directed to them and to all people.

Possible Activities

- Talk with the children about times when they have invited friends or family to come to a special event, like a birthday celebration. What did they do to encourage people to come? Read with the children 2 Nephi 26:23–28, 33, and help them find what the Lord is inviting us to do. Ask the children to create a card or letter inviting someone to come unto Jesus Christ. Encourage them to use a phrase from these verses in their invitation (if needed, write some phrases on the board to help).
- Read 2 Nephi 26:33 with the children, and help them make a list of who, according to this verse, is invited to “partake of [the Lord’s] goodness.” (You may need to explain that “the heathen” are those who don’t believe in God.) Invite them to add their own names to the list. How do we partake of the Lord’s goodness?
- Talk with the children briefly about how children around the world are different, and testify that the Lord loves all of them (see 2 Nephi 26:24, 33). Invite the children to draw a picture of Jesus with many different children.

2 NEPHI 28:27–30**Heavenly Father reveals truth
“line upon line.”**

Nephi warned against the attitude that we don’t need any more truth from God. Help the children see gospel learning as a gradual, lifelong pursuit.

Possible Activities

- Choose a phrase from 2 Nephi 28:30, and ask a child to write the first word on the board. Then ask another child to write the next word, and so on until the whole phrase is written. How is this activity similar to the way God gives us truth?
- Help the children read and understand 2 Nephi 28:27–30, looking for answers to a question like this: What do these verses teach about people who believe they have enough truth and need no more? Ask them to suggest ways we can show the Lord that we want to receive more truth from Him.

2 NEPHI 29:7–11**The Book of Mormon and the Bible
work together.**

Because we have the Bible, some people believe that the Book of Mormon is unnecessary. These verses can help the children understand, and explain to others, why we are thankful for both books of scripture.

Possible Activities

- Give one child a copy of the Book of Mormon and another a copy of the Bible. Ask them how these books are similar and how they are different. Show the children a map of the world, and help them match each book with the part of the world it came from. Read and discuss 2 Nephi 29:8. Why did God give us two “testimonies” or books of scripture that teach us about Him?
- Ask the children to imagine that a friend told them, “I don’t need to read the Book of Mormon. I’ve already read the Bible.” Read together 2 Nephi 29:7–11, explaining phrases and concepts as needed. Then ask them to share ideas about what they might say to their friend.

**Encourage Learning at Home**

Invite the children to explain to their families how the Bible and the Book of Mormon work together to testify of Jesus Christ.

Improving Our Teaching

Focus on people, not lessons. The ideas in this outline are only suggestions. Feel free to adapt them to the needs and abilities of the children you teach.

The Book of Mormon is a blessing (2 Nephi 28:2; 30:6).

Color and cut out the four pages. Staple them together to make a book. Draw some of your favorite Book of Mormon stories on the back of each page.

**Book
of
Mormon
Stories**

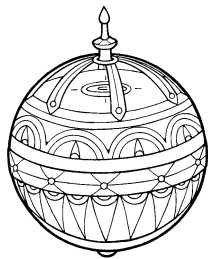

Name

Samuel the Lamanite

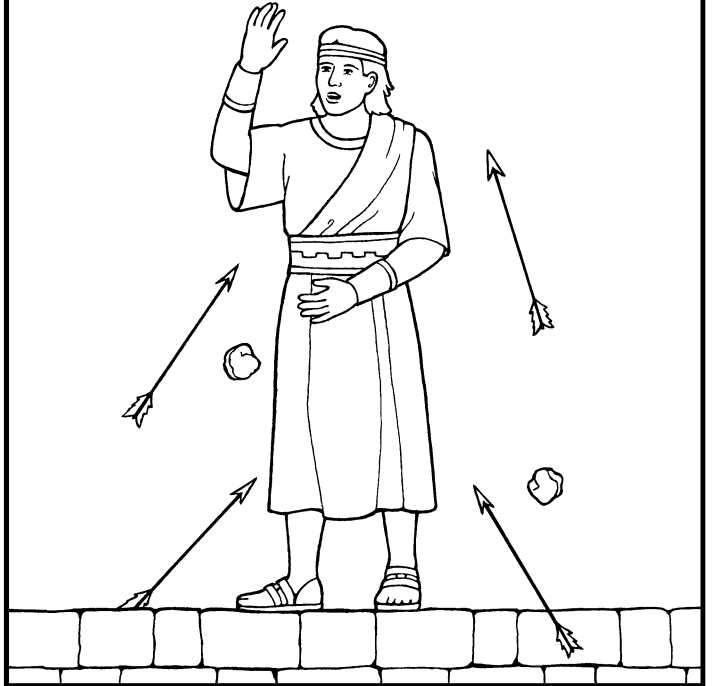

Helaman's Army



Mormon





MARCH 2-8

2 Nephi 31-33

“THIS IS THE WAY”

Start your preparation by reading 2 Nephi 31-33. Seek the Spirit’s guidance about what to teach the children. This outline can give you ideas.

RECORD YOUR IMPRESSIONS _____



Invite Sharing

Because Nephi taught about the baptism of Christ, ask the children to share something they have learned about baptism. They could also share thoughts and feelings about their own baptisms or the baptisms of friends or family members.



Teach the Doctrine: Younger Children

2 NEPHI 31

Jesus Christ taught me how to return to Heavenly Father.

Nephi taught that following the Savior’s example and teachings is the only way to “be saved in the kingdom of God” (2 Nephi 31:21).

Possible Activities

- Display the picture in this week’s outline in *Come, Follow Me—For Individuals and Families* while you summarize the account of Jesus’s baptism (see 2 Nephi 31:4-13). Explain that baptism is one step on the path back to living with Heavenly Father. Invite someone who was recently baptized to tell the children how he or she feels about baptism.
- Explain that Jesus Christ taught us what we need to do to return to Him after we die. Draw a path on the board, and place a picture of Christ at the end of it. Give the children pictures that represent elements of the doctrine of Christ (faith in Christ, repentance, baptism, the gift of the Holy Ghost, and enduring to the end). Help them place the pictures along the path.
- Help the children learn the fourth article of faith. Sing together a song about one of the first principles of the gospel, such as “Faith,” “When I Am Baptized,” or “Choose the Right Way” (*Children’s Songbook*, 96-97, 103, 160-61).

2 NEPHI 32:3

I can feast upon the words of Christ.

How can your experiences with “feast[ing] upon the words of Christ” (2 Nephi 32:3) help the children understand this phrase?

Possible Activities

- Ask the children to name some of their favorite foods, and invite them to act out how they would feast on them. Read 2 Nephi 32:3, and ask the children to listen for what Nephi says we should feast on. What does it mean to feast on the scriptures? Explain that the scriptures are one place where we can find the words of Christ.
- Write the words *God* and *Lord* on the board. Invite the children to open to a page of scripture and look for these words. Give them help if needed. Testify that as we read the scriptures, we can learn about God.

2 NEPHI 32:8-9

Heavenly Father wants me to pray always.

These verses can inspire the children to make prayer part of their daily lives.



We can talk to God through prayer.

Possible Activities

- Ask the children when they pray. Do they pray in the morning? at night? before meals? Help the children think of actions to show when we can pray, such as when we wake up, go to bed, and

eat—or any other time. Read to them the first line or two from 2 Nephi 32:9, and emphasize the phrase “pray always.”

- Ask the children how they pray. What do they do with their head, hands, and so on? What sorts of things do they say? Ask them to imagine that you don’t know how to pray, and let them teach you. Why does Heavenly Father want us to pray?



**Teach the Doctrine:
Older Children**

2 NEPHI 31

Jesus Christ taught me how to return to Heavenly Father.

We can return to God after this life by following the doctrine Jesus Christ taught: faith in Christ, repentance, baptism, the gift of the Holy Ghost, and enduring to the end.

Possible Activities

- Display the picture in this week’s outline in *Come, Follow Me—For Individuals and Families*, and ask the children to share what they know about Jesus’s baptism (see Matthew 3:13–17). Put the following words in random order on the board: *Jesus witnessed unto the Father that He would be obedient unto Him*. Invite the children to read 2 Nephi 31:7 as a class and put the words into the correct order.
- Ask the children what they would say to someone preparing to be baptized, and help them compile their advice onto simple cards they could give to someone. How can we continue to follow the example of Jesus after we are baptized?
- Explain that the doctrine of Christ includes the things Jesus Christ taught that we need to do

to return to Heavenly Father. Write on different sheets of paper *faith in Christ, repentance, baptism, the gift of the Holy Ghost, and enduring to the end*, and scatter them around the room. Read to the children 2 Nephi 31:11–19, and invite the children to take turns jumping from paper to paper as they hear these principles mentioned. Help them think of an experience they have had with each principle.

2 NEPHI 32:3–5

I can feast upon the words of Christ.

Why do children need to understand the importance of feasting on the words of Christ?

Possible Activities

- Ask the children to imagine a feast. What food would they want there? What would they eat first? Then invite them to imagine what feasting on the scriptures might mean as you read 2 Nephi 32:3. Why did Nephi use the word *feast* to teach us how we should study God’s word? Why didn’t he just say *read*? What does it mean to feast on the scriptures? Share with the children the blessings you’ve received as you’ve feasted on the scriptures.
- Complete the activity page with the children, and invite them to make a goal to do at least one thing to feast on the scriptures this week.

2 NEPHI 32:8–9

Heavenly Father wants me to pray always.

The adversary tempts us not to pray. Consider how you can help the children resist this temptation and “pray always” (2 Nephi 32:9).

Possible Activities

- Choose a phrase about prayer from 2 Nephi 32:8–9, write it on the board, and cover each word with a piece of paper. Invite the children to take turns removing one paper at a time until they can guess what the phrase is.
- Read 2 Nephi 32:8–9 together, and ask the children to share what they learn about prayer from these verses. What does it mean to “pray always”? (verse 9). How can we do this?
- What might make someone not want to pray? Share an experience when you prayed even though you didn’t feel like it. How did you feel afterward? Invite a child to read the second half of 2 Nephi 32:8, and give the children time to ponder it. Why doesn’t Satan want us to pray? How can we remind ourselves to pray even when we don’t feel like it?



Encourage Learning at Home

Encourage the children to find someone—a friend, a sibling, or another family member—they can teach how to pray.

Improving Our Teaching

Children are active. Invite the children to act out scripture stories and songs. Use their active natures to enhance learning. (See *Teaching in the Savior’s Way*, 25–26.)

I can "feast upon the words of Christ" (2 Nephi 32:3).

Color and cut out the squares containing different foods. On the back of each square, write something you can do to "feast upon the words of Christ," and place the foods on the plate.

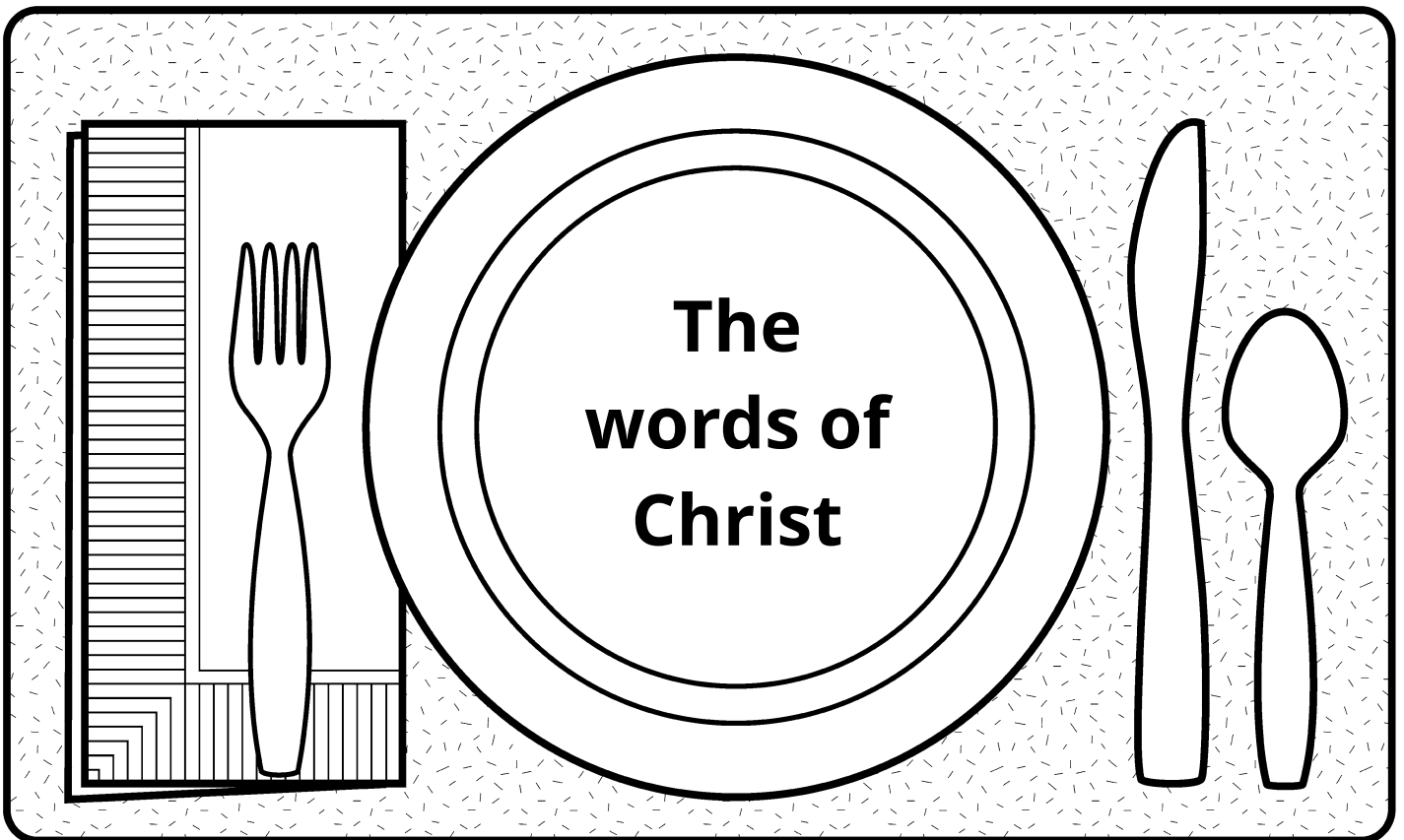
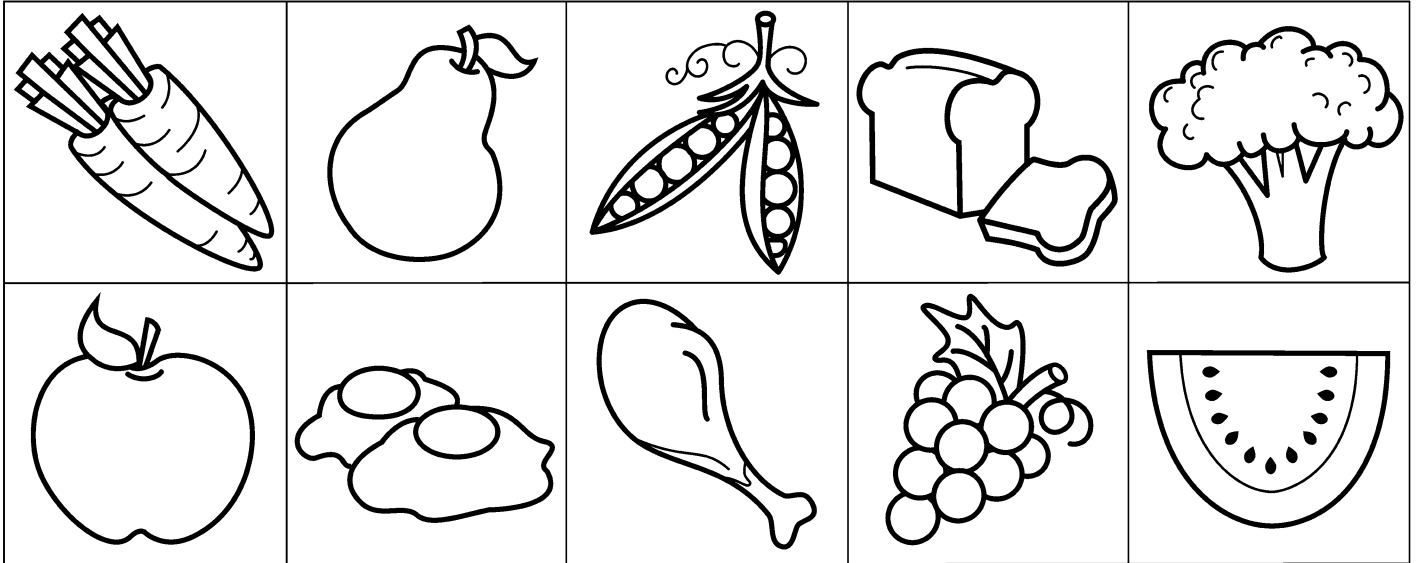



Forgiven, by Greg K. Olsen

MARCH 9-15

Jacob 1-4

BE RECONCILED UNTO GOD THROUGH THE ATONEMENT OF CHRIST

As you read Jacob 1-4, ponder which principles from these chapters are most important for the children to learn. Seek for spiritual guidance to know how best to teach these principles, and record your impressions.

RECORD YOUR IMPRESSIONS _____



Invite Sharing

Invite the children to share something they or their families did this week to learn from Jacob 1-4. You could also ask them to share something they remember from last week's lesson. What questions could you ask to help them remember?



Our Church leaders help us follow Jesus Christ.



Teach the Doctrine: Younger Children

JACOB 1:6-8, 18; 2:1-11

God calls Church leaders to help me follow Jesus Christ.

Help the children understand that they will be blessed by following the counsel of Church leaders.

Possible Activities

- Make simple puppets to represent Jacob and Joseph, Nephi's younger brothers, who were leaders in the Church. Share some verses from Jacob 1 and 2 to explain what Church leaders are called to do. For example, leaders persuade us to "believe in Christ" (Jacob 1:8), invite us to repent (see Jacob 2:5-6, 9-10), and "declare [God's] word" (Jacob 2:2, 11). Let the children use the puppets to pretend to do some of these things.
- Invite the children to name some Church leaders they know, like Primary leaders, bishopric

members, and prophets and apostles. Help the children think of ways these leaders bless us.

JACOB 2:12–14, 17–21

I can help others in need when I share with them.

Do the children you teach understand the blessings that come when they share with those in need? How can you help them know that Heavenly Father and Jesus want them to help others?

Possible Activities

- Explain that some of the people in Jacob’s time were very rich, but they didn’t want to share what they had with people who were poor. Read Jacob 2:17–19 to help the children understand Jacob’s teachings to these people. As you do, give the children pictures or objects to hold that go with words or phrases in these verses.
- Invite the children to act out ways they can share what they have with someone in need. Testify that we are blessed as we share with others.
- Bring something to class that you can share with the children. Give some of it to each child, and explain that you are sharing. Ask them how they felt when you shared with them. How do they feel when they share with others? Help them think of something they could share to help someone feel happy.

JACOB 4:6

I can strengthen my faith in Jesus Christ.

As Jacob lived righteously despite the wickedness around him, his faith became so strong that it could not be shaken. Ponder how you can help the children understand what it means to have faith that cannot be shaken.

Possible Activities

- Help the children think of things they do to make their bodies stronger. What can we do to make our faith stronger? Open the scriptures to Jacob 4:6, and help the children discover what Jacob and his people did to make their faith “unshaken.”
- Sing “The Wise Man and the Foolish Man” (*Children’s Songbook*, 281) with the children. On one side of the board, draw a house built on the sand. On the other side of the board, draw a house built on a rock. If possible, bring sand and a rock to class. Which is easier to shake or move? Which one, sand or rock, do we want our faith to be like?



Teach the Doctrine: Older Children

JACOB 1:6–8, 18; 2:1–6, 11

God calls Church leaders to help me follow Jesus Christ.

The children you teach will be blessed as they trust and follow the counsel of Church leaders.

Possible Activities

- Read with the children Jacob 1:6–8 and 2:1–6, 11, helping them look for phrases that describe how God’s servants lead the Church. Ask them to write these phrases on pieces of paper and then display the papers on the board. Why does God call Church leaders to guide us? Ask the children to share experiences with learning or receiving guidance from a Church leader or teacher and the blessings they received.
- Ask the children to draw a picture of a Church leader they know about, and let the rest of the class guess who they drew. What do these leaders do to help us follow Jesus Christ? Invite the

children to write notes to Church leaders, thanking them for their service.

- Invite a local Church leader to tell the children what he or she does to fulfill his or her calling. Ask the children to name some things they can do to sustain their leaders.

JACOB 2:12-14, 17-21

I can help others feel happy by sharing with them.

True followers of Jesus Christ are willing to share what they have with others. Encourage the children to bring joy to those in need by sharing with them.

Possible Activities

- Tell the children that many people in Jacob's time became prideful and unkind because they loved riches (see Jacob 2:12-14, 17-21). Invite a few children to read Jacob 2:17-19 out loud, and help them understand any difficult words. What should we seek before we seek riches? What should we seek to do with any riches we receive?
- Read Jacob 2:17 to the children. What blessings has Heavenly Father shared with us? Why does He want us to share with each other? Invite the children to share times when they shared something with someone else, including how they felt and how the other person felt.

JACOB 4:4-13, 17

I can strengthen my faith in Jesus Christ.

Jacob's faith became unshaken as he searched the words of prophets and received his own witness (see Jacob 4:6). How can you help the children desire to build faith that cannot be shaken?

Possible Activities

- Invite the children to think of things that become strong and secure over time, such as a large tree. How is faith like the things they thought of? What phrases in Jacob 4:6, 10-11 describe what we can do to make our faith unshaken? Ask the children to make a list on the board of ways they can strengthen their faith in Jesus Christ.
- Share Elder Neil L. Andersen's analogy of the tree growing in a windy environment, found in his message "Spiritual Whirlwinds" (*Ensign* or *Liahona*, May 2014, 18-21), or show the video "Spiritual Whirlwinds" (ChurchofJesusChrist.org). Why is it important for our faith to be unshaken and strong like the trunk of a tree? What do the whirlwinds represent? What can we do to build unshaken faith? Help the children think of other analogies that teach about having faith that cannot be shaken.



Encourage Learning at Home

Invite the children to think of something they can share with their families—including sharing something they learned in class today. Give them opportunities in a future lesson to talk about what they shared.

Improving Our Teaching

Encourage reverence. Help the children understand that an important aspect of reverence is thinking about Heavenly Father and Jesus Christ. You might remind them to be reverent by quietly singing or humming a song or displaying a picture of Jesus.

I can help others in need when I share with them (Jacob 2:12-14, 17-21).

Cut out the arrow, and attach it to the center of the circle. Spin the arrow, and tell about how you can share what the arrow points to.

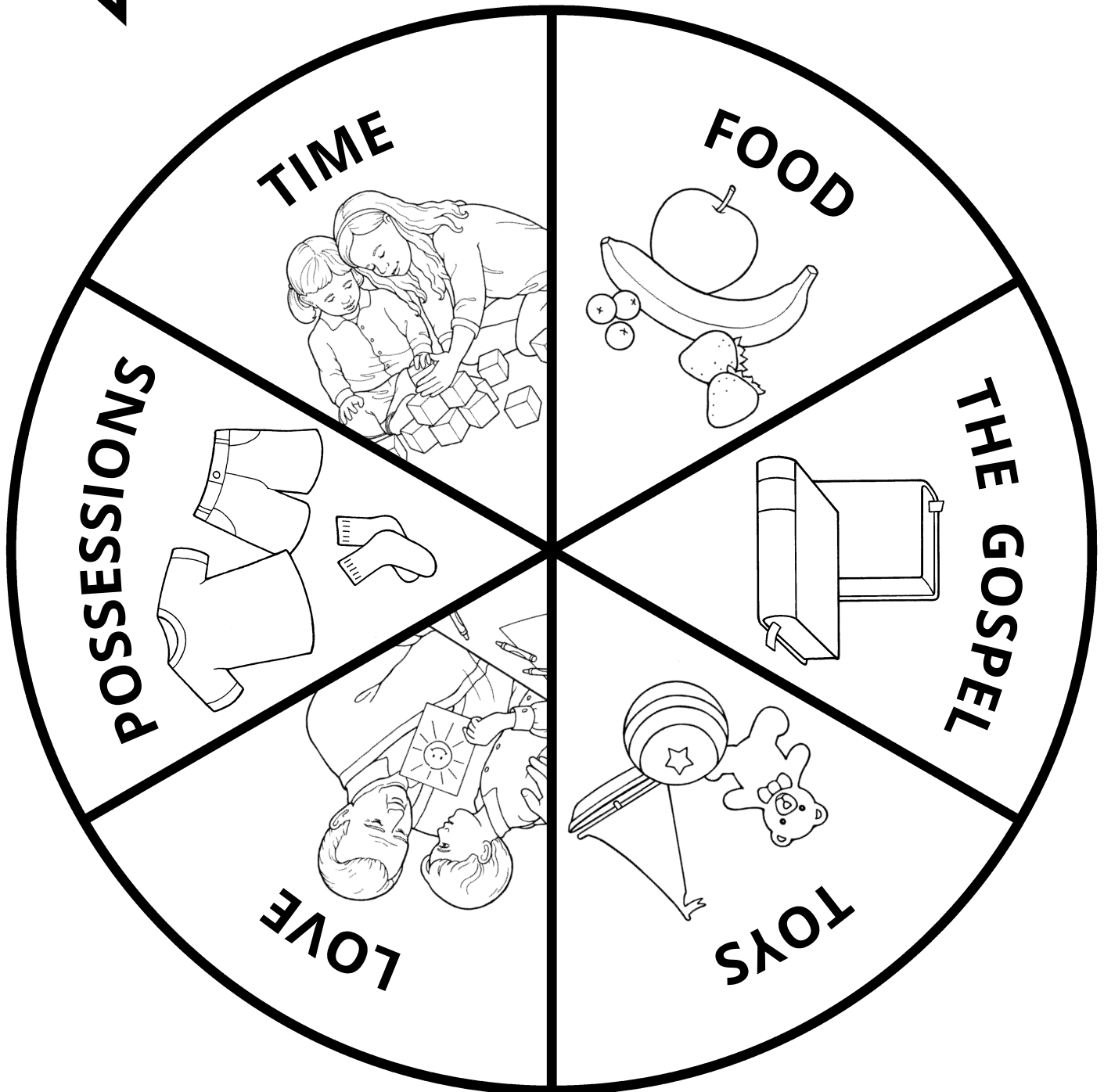
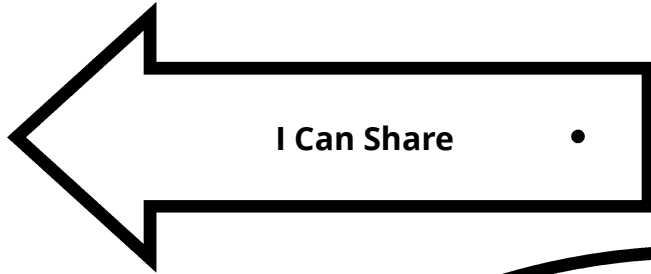



Allegory of the Olive Tree, by Brad Teare

MARCH 16-22

Jacob 5-7

THE LORD LABORS WITH US

Study, ponder, and pray to know how you can best teach the children the truths found in Jacob 5-7. Record any impressions you receive.

RECORD YOUR IMPRESSIONS _____



Invite Sharing

To begin a discussion about the messages found in Jacob 5-7, invite the children to talk about things in their lives that help them feel the love of Heavenly Father and Jesus Christ. How do we show our love for others?



Teach the Doctrine: Younger Children

JACOB 5

Missionaries serve Heavenly Father's children.

Ponder how you can share the allegory of the olive trees in a way that the children can understand.

Possible Activities

- Show a picture of a tree, or take a walk outside to look at a tree, and briefly review the main points of the allegory of the olive trees in Jacob 5. For example: the Lord of the vineyard (who could represent Jesus) worked very hard to look after his olive trees (which could represent the people on earth) because He cared so much about them. He called laborers (who could represent missionaries) to help care for the trees. Pick one or two verses from Jacob 5 to read to the children (such as verses 71-72).
- Ask the children if they know someone who has served a mission, or talk about someone you know. Help the children locate on a map the places where those missionaries are serving. Explain that Jacob compared the world to a group of olive trees. The trees are like the people on earth, and caring for those trees is like what missionaries do for God's children. What do missionaries do to bless Heavenly Father's children? Look together for some answers to this question in a song such as "Called to Serve" (*Children's Songbook*, 174-75). How can we be like missionaries?



Missionary work is one way we can help God's children return to Him.

JACOB 6:5

Heavenly Father loves me.

How can you teach your class that God loves all of His children and extends His “arm of mercy” toward them?

Possible Activities

- Invite the children to give themselves a hug. How do we feel when someone we love gives us a hug? Read Jacob 6:5 to the children, and explain that the phrases “[God] cleaveth unto you” and “his arm of mercy is extended towards you” teach that Heavenly Father loves us and wants us to come back to Him someday.
- Sing together a song about love, such as “I Feel My Savior’s Love” (*Children’s Songbook*, 74–75). Invite the children to name things that help them feel the Savior’s love.

JACOB 7:1–23

I can stand up for what I know is true.

Jacob is an excellent example of someone whose firm testimony helped him defend the truth in the face of opposition.

Possible Activities

- Tell the story of Jacob and Sherem (Jacob 7:1–23) in a way the children can understand. You could

use “Chapter 10: Jacob and Sherem” (*Book of Mormon Stories*, 27–29, or the corresponding video on ChurchofJesusChrist.org). Then tell the story again, but this time allow the children to help fill in details. Ask them what they learn from Jacob. How can we follow his example?

- Invite the children to sing a song about choosing the right, such as “Dare to Do Right” or “Stand for the Right” (*Children’s Songbook*, 158, 159). Ask them to stand whenever they sing words like *right* or *true*.



Teach the Doctrine:
Older Children

JACOB 5

The Lord cares for His people.

Jacob shared the allegory of the olive trees to help invite His people to come unto Christ. It can accomplish this same purpose for the children you teach.

Possible Activities

- Read and explain to the children key verses summarizing the allegory of the olive trees, such as Jacob 5:3–4, 28–29, 47, and 70–72, and invite the children to draw pictures of what these verses describe. What do we learn from these verses about how the Lord feels about His people? Ask the children to pretend to take care of an olive tree as you briefly summarize verses 61–71 (they might act out digging, watering, and so on). Invite a few children to read Jacob 5:11, 41, 47, and 72, looking for things that show how much the Lord of the vineyard (Jesus Christ) cared about the trees. What does the Savior do to show He cares about us? The video “Old Testament Olive Vineyard” (ChurchofJesusChrist.org) can help with this activity.

- List some of the symbols in Jacob 5 on the board, such as the vineyard, the lord of the vineyard, the servant, and the olive trees. Then make another list, in random order, of the things these symbols might represent, such as the world, the Savior, Church leaders or missionaries, and God’s people. Read together verses from Jacob 5 that mention these symbols, and help the children draw lines on the board connecting the symbols with their possible meanings (see, for example, verses 3–4, 28–29, 47, 70–72).

JACOB 6:4-5

Heavenly Father loves me and will forgive me when I repent.

It is important to help the children you teach understand that God loves them and will always forgive them as they sincerely repent.

Possible Activities

- Make a chart on the board with two columns labeled *Heavenly Father* and *Us*. Read together Jacob 6:4–5, and ask half of the class to look for phrases that apply to God and the other half to look for phrases that apply to us. Record what they discover in the appropriate column. Help them define words they do not understand.
- Share Elder Allen D. Haynie’s story about getting dirty in a mud pit in his message “Remembering in Whom We Have Trusted” (*Ensign* or *Liahona*, Nov. 2015, 121–22). What does this story teach us about what we need to do to be saved in the kingdom of God? What else do we learn from Jacob 6:4–5?

JACOB 7:1-23

I can stand up for what I know is true.

How can you inspire the children to stand for truth like Jacob did?

Possible Activities

- Invite the children to act out the interaction between Jacob and Sherem, using Jacob 7:1–23 as a guide. Or show the video “Jacob and Sherem” (ChurchofJesusChrist.org). Ask the children to talk about their favorite parts of the story. How did Jacob stand for what he knew was right? Invite the children to share experiences when they stood for the right, or share your own.
- Invite the children to sing a song about choosing the right, such as “Dare to Do Right” or “Stand for the Right” (*Children’s Songbook*, 158, 159). Divide them into groups, and invite them to create an inspirational banner or poster that represents something that they stand for or believe in.



Encourage Learning at Home

Invite the children to think of a way they can help their families feel the Savior’s love—for example, by explaining what they learned about how the lord of the vineyard cared for his olive trees.

Improving Our Teaching

Children like to share what they are learning.

Although they are young, children can strengthen their family members. Encourage them to share with their families the things they learn in Primary. (See *Teaching in the Savior’s Way*, 30.)

Missionaries serve Heavenly Father's children (Jacob 5).

Missionaries help God's children like laborers who care for trees in a vineyard. Help the missionaries find their way through the maze. How do missionaries help God's children?

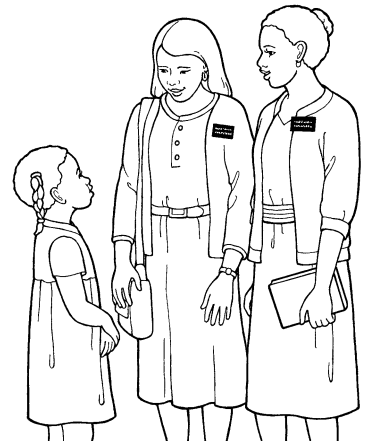
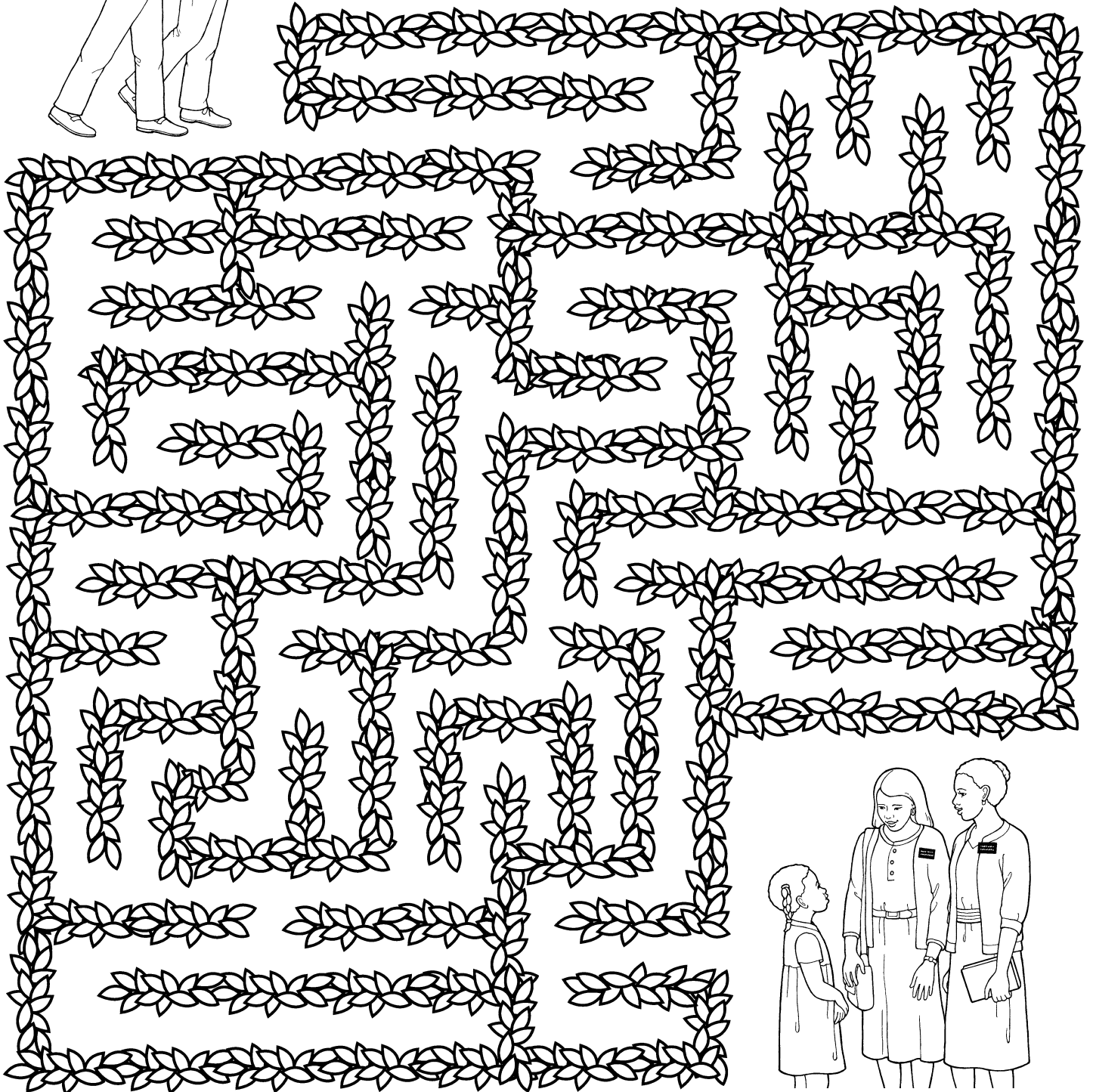
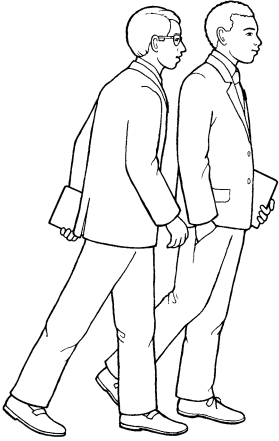



MARCH 23-29

Enos—Words of Mormon

HE WORKS IN ME TO DO HIS WILL

Enos, Jarom, Omni, and Words of Mormon are short books that have many precious lessons for the children you teach. Search for these lessons, and ponder ways you can help the children learn them. The ideas in this outline may help.

RECORD YOUR IMPRESSIONS _____



Invite Sharing

Help the children remember what they learned from last week's lesson. Did they share what they learned with their family or others?



Teach the Doctrine: Younger Children

ENOS 1:1-19

I can talk to Heavenly Father through prayer.

Enos's experience teaches several truths about prayer. How will you inspire the children to follow Enos's example as they pray?

Possible Activities

- Show a picture of Enos; for example, see this week's outline in *Come, Follow Me—For Individuals and Families*, or use the picture Enos Praying (*Gospel Art Book*, no. 72). Ask the children to talk about what is happening in the picture, and then share Enos's experience with them. You could use "Chapter 11: Enos" (*Book of Mormon Stories*, 30–31, or the corresponding video on ChurchofJesusChrist.org).
- Ask the children to share things they like to talk about with their parents. Explain that praying to Heavenly Father is how they can talk to Him. As you read Enos 1:1–4 to the children, invite them to pretend to be Enos by acting out hunting, kneeling to pray, and so on. Explain that Heavenly Father heard Enos's prayer and forgave his sins.
- Sing together a song about prayer, such as "A Child's Prayer" (*Children's Songbook*, 12–13). Invite the children to raise their hands every time they hear the word "prayer" or another repeated word. Testify of the power of prayer in your life.



As children of God, we can pray to our Heavenly Father.

WORDS OF MORMON 1:3–8

I can bless others when I listen to the Holy Ghost.

When he was compiling the Book of Mormon, Mormon was prompted to include the small plates of Nephi. He didn't know why the small plates were needed, but today we are blessed because he followed this prompting. This example can inspire the children to follow the Spirit.

Possible Activities

- Invite the children to share stories they have learned from the Book of Mormon so far this year (pictures from *Come, Follow Me—For Individuals and Families* or the *Gospel Art Book* may help them remember). Explain that we have these stories in the Book of Mormon because Mormon listened when the Holy Ghost told him to include them. Why did Heavenly Father want us to have these stories?
- Share a story from Church magazines or from a general conference message about someone who followed the promptings of the Holy Ghost. Or share one of your own experiences. Invite the children to draw pictures of the story. How were the people in these stories blessed because they followed the Holy Ghost?
- Ask a ward member to visit the class and share an experience when he or she followed a prompting from the Holy Ghost. How did his or her actions

bless others? Explain that Heavenly Father wants us to help and bless others, so He sends the Holy Ghost to guide us.

- Sing together a song about the Holy Ghost, such as “The Still Small Voice” (*Children’s Songbook*, 106–7). Sing it several times in different ways, such as fast, slow, or in a whisper. When you whisper the song, open to Words of Mormon 1:7, and point out that Mormon described the Holy Ghost as a whisper.



Teach the Doctrine: Older Children

ENOS 1:1–19

Heavenly Father hears and answers my sincere prayers.

It can be easy for our prayers to become routine or casual. Enos's experience is a reminder that receiving answers to our prayers sometimes requires a “wrestle” and “many long strugglings” (Enos 1:2, 11).

Possible Activities

- Invite the children to close their eyes and imagine they are talking to Heavenly Father face-to-face. What would they like to talk about with Him? Invite the children to think about talking face-to-face with Heavenly Father each time they pray.
- Invite the children to work in pairs and read Enos 1:1–5. Ask them to search these verses for a word or phrase that describes Enos's prayers and then share what they find with the class. What do these words suggest about Enos and his experience? Let the children share anything else that impresses them about Enos's prayers. Share an experience when your soul “hungred” and

you “cried unto” the Lord (Enos 1:4). Allow the children to ponder one thing they can do to make their prayers more meaningful.

- Ask the children to list some things they typically pray for, either on the board or on this week’s activity page. Then invite them to search Enos 1:2, 9, 13–14, and 16 for the things Enos prayed for, and add those things to the list. Discuss how the children can follow Enos’s example in their prayers; for instance, you could talk about why Enos was willing to pray for the Lamanites—who were his enemies—and invite the children to pray this week for someone who has been unkind to them.

WORDS OF MORMON 1:3–8

I can bless others when I listen to the Holy Ghost.

The Lord knew that the first 116 translated pages of the Book of Mormon would be lost (see D&C 10; *Saints*, volume 1, chapter 5). To replace this loss, He inspired Mormon through the Spirit to include the small plates of Nephi in the Book of Mormon. How can you inspire the children to follow Mormon’s example and listen to the Spirit?

Possible Activities

- Ask the children to take turns reading the verses from Words of Mormon 1:3–8 one at a time, and then help them summarize what they learn from each verse. Explain that Mormon followed the Spirit by including the small plates of Nephi (which we now have as 1 Nephi through Omni) in the Book of Mormon. How are we blessed because Mormon listened to the Spirit? How might the Book of Mormon be different if he hadn’t

listened? Share an experience in which you were prompted by the Holy Ghost to do something that blessed someone. Invite the children to share any similar experiences they may have had.

- Invite one child to read Words of Mormon 1:7 and another to read Doctrine and Covenants 8:2–3. What do these verses teach about how the Holy Ghost speaks to us? Help the children identify times when they have felt promptings from the Holy Ghost. Use Moroni 7:12 to explain that if a thought is good and inspires us to do good things, it comes from Heavenly Father. For an example, consider showing the video “Preparation of Thomas S. Monson: Always Follow the Promptings of the Spirit” (ChurchofJesusChrist.org). Invite the children to listen for promptings to do good and follow them.



Encourage Learning at Home

Encourage the children to ask their family members to share experiences they’ve had with prayer or the Holy Ghost.

Improving Our Teaching

Use music. Primary songs and hymns can help children of all ages understand and remember gospel truths. Singing can also keep children actively engaged in a learning experience. (See *Teaching in the Savior’s Way*, 22.)

I can talk to Heavenly Father through prayer (Enos 1:1-19).

In the first two boxes, write or draw pictures of some of the things Enos prayed for.

In the third box, write or draw something you can pray about.

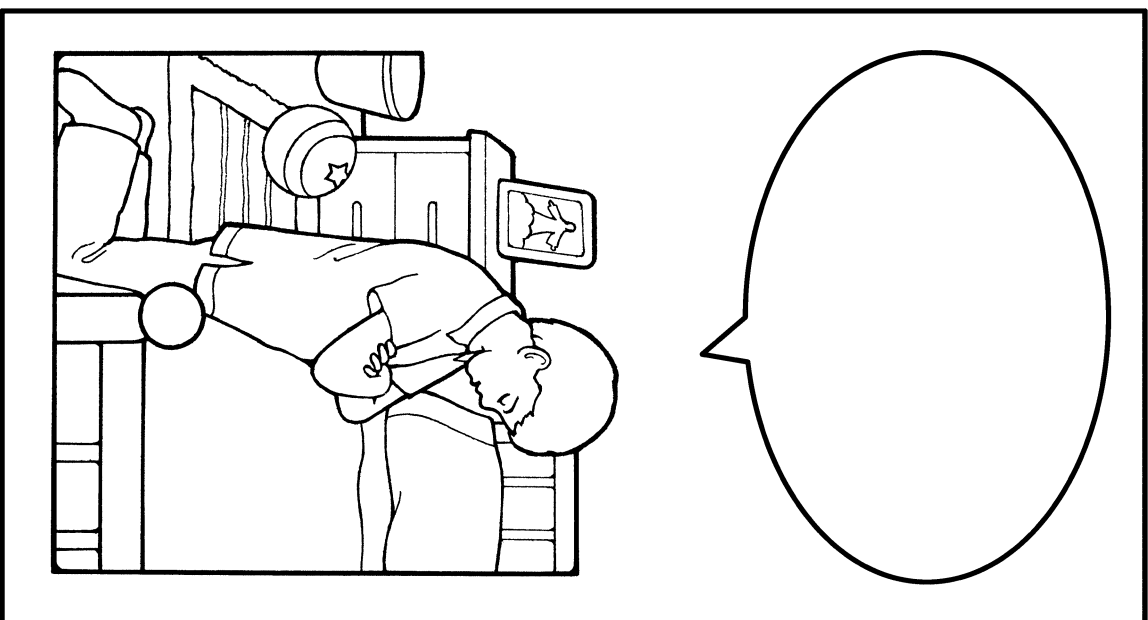
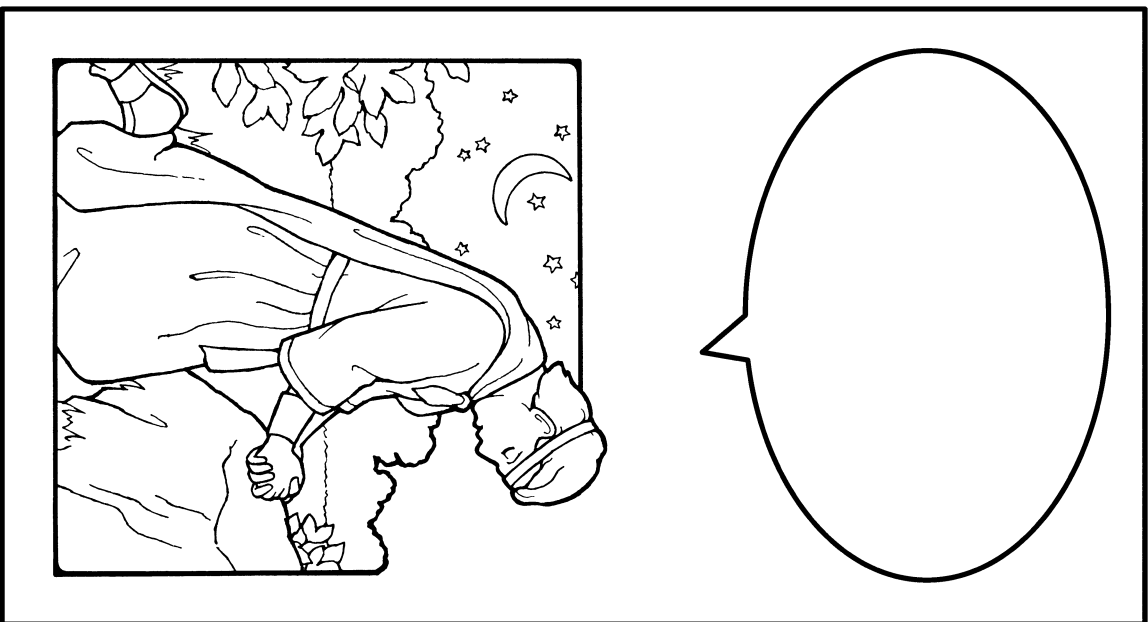
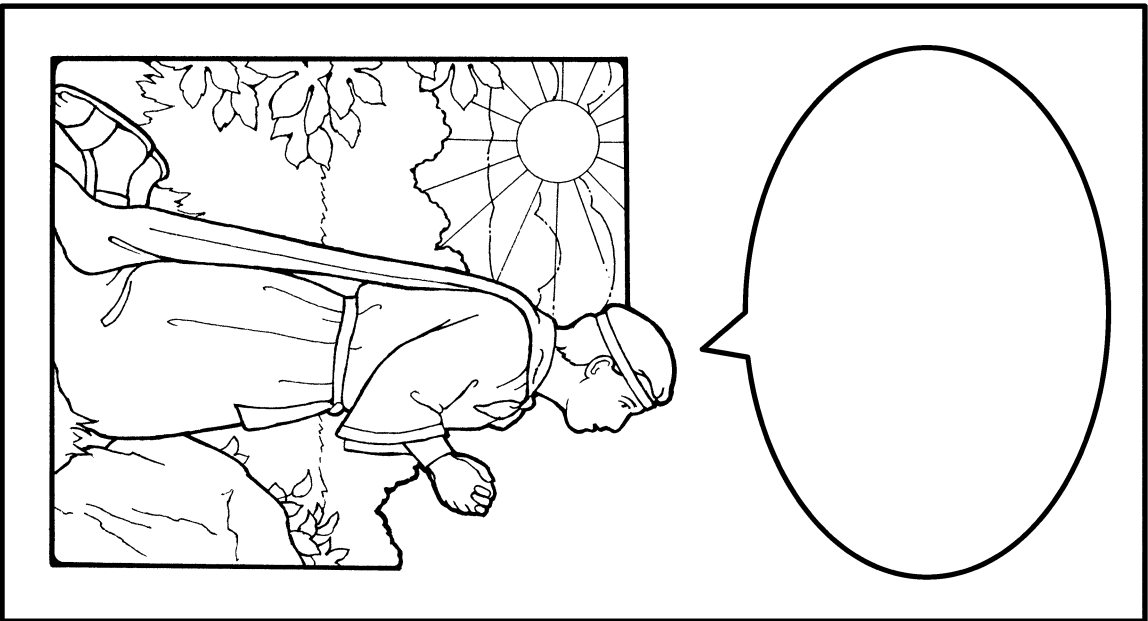



MARCH 30–APRIL 12

Easter

“HE SHALL RISE . . . WITH HEALING IN HIS WINGS”

As you read the scriptures suggested here and in *Come, Follow Me—For Individuals and Families*, the Spirit will help you know what to focus on to help the children feel the Savior’s love on Easter Sunday.

RECORD YOUR IMPRESSIONS _____



Invite Sharing

Talk to the children about things you do to remember the Savior at Easter. Invite them to share what they do.



Teach the Doctrine: Younger Children

1 NEPHI 11:27; MOSIAH 3:5; 15:7; HELAMAN 14:16–17

Book of Mormon prophets knew that Jesus Christ would come.

Learning what the prophets in the Book of Mormon taught about Jesus Christ’s mission and earthly ministry can help strengthen the children’s faith in Him.

Possible Activities

- Display pictures of the Savior being baptized, healing others, being crucified, and as a resurrected being (see this week’s activity page or *Gospel Art Book*, nos. 35, 41, 57, 59). Ask the children to tell you what is happening in each picture. Explain that many years before Jesus came to earth, God revealed to prophets in the Book of Mormon that He would do these things. Read 1 Nephi 11:27; Mosiah 3:5; 15:7; and Helaman 14:16–17, and help the children match these scriptures with the corresponding pictures.
- As the children work on this week’s activity page, talk about the prophets pictured and what they taught about Jesus Christ. Share with the children some of the wonderful things Jesus has done for us.

3 NEPHI 11:1–17

Jesus Christ was resurrected.

Teach the children that in addition to the people who saw the resurrected Savior in Jerusalem, thousands saw Him when He appeared in the Americas.

Possible Activities

- Show pictures of the Savior’s death and Resurrection. Ask the children what they know about these events. As needed, use “Chapter 53: Jesus Is Crucified” and “Chapter 54: Jesus Is Risen” (*New Testament Stories*, 136–38, 139–44, or the corresponding videos on ChurchofJesusChrist.org) to tell the children these stories.
- Using pictures from the *Gospel Art Book* or *Come, Follow Me—For Individuals and Families*, tell the children about the resurrected Savior’s visit to the Americas, as described in 3 Nephi 11:1–17. Repeat the story several times, inviting children to help you. Emphasize details that you feel would be meaningful to the children. In particular, emphasize that even though Jesus had died on the cross, the people could see that He was now resurrected. Let the children take turns retelling the story in their own words.
- Sing together “Easter Hosanna” or the last verse of “Book of Mormon Stories” (*Children’s Songbook*, 68–69, 118–19). Invite the children to draw pictures of something the song describes. Then ask the children to share their drawings and what they think it would have felt like to be there when Jesus visited the Nephites.

MOSIAH 3:7; ALMA 7:11–12

Jesus Christ knows how to comfort me.

Because Jesus Christ suffered “the pains and the sicknesses of his people” (Alma 7:11), He knows how we feel, even when no one else does.

Possible Activities

- Read to the children the first few lines of Mosiah 3:7, and invite them to pretend they are feeling “pain . . . , hunger, thirst, and fatigue [tiredness].” Ask them to share times when they have felt these things. Then tell the children that this

verse describes some things Jesus Christ felt when He suffered in the Garden of Gethsemane. Because of this, He knows how to help us when we feel these things.

- Read Alma 7:11 aloud, and ask the children if they know someone who is sick or in pain. Testify that Jesus Christ felt all of our “pains and sicknesses” so that He could understand how to comfort us (Alma 7:12).



Teach the Doctrine: Older Children

2 NEPHI 9:10–15; ALMA 11:41–45; 40:21–23

Because Jesus Christ was resurrected, I will be resurrected too.

The Book of Mormon clearly describes what resurrection means and who will be resurrected. How can you help the children discover these truths?

Possible Activities

- Ask the children to tell you what they know about the death and Resurrection of Jesus Christ. Write on the board questions like *What does it mean to be resurrected?* and *Who will be resurrected?* Help the children find answers in 2 Nephi 9:10–15; Alma 11:41–45; and Alma 40:21–23 and share with the class what they find.
- Tell the children about someone you know who has died. Ask them to pretend that you don’t know about the Resurrection. How would they help you understand what it is? Encourage them to use 2 Nephi 9:10–15; Alma 11:41–45; or Alma 40:21–23 to teach you about resurrection. Also invite them to bear testimony of the Savior’s Resurrection as part of their answer.



Gethsemane, by Michael T. Malm

ENOS 1:2-8; MOSIAH 27:8-24; ALMA 13:11-12; 24:7-19

The Atonement of Jesus Christ cleanses me and changes me.

The Book of Mormon gives many examples of people who were changed because of the Savior's Atonement. Consider how these experiences might inspire the children to repent and turn to the Savior.

Possible Activities

- Show the children a clean white shirt and a dirty white shirt. Read together Alma 13:11-12. How were the people made clean from their sins? How did this make them feel about sin? Talk about how you feel when you repent and receive forgiveness, and bear your testimony of the Savior's power to cleanse us from sin.
- Invite the children to choose one of the following people to learn about: Enos (see Enos 1:2-8), Alma the Younger (see Mosiah 27:8-24), or the Anti-Nephi-Lehies (see Alma 24:7-19). As you read the story together, invite the children to notice how this person or group changed because of the Atonement of Jesus Christ. How can we follow the examples of these people?

MOSIAH 3:7; 15:5; ALMA 7:11

Jesus Christ took upon Himself my sins, pains, and sicknesses.

In addition to suffering for our sins, the Savior also suffered our pains, sicknesses, and other infirmities so He would know how to comfort us.

Possible Activities

- Assign each child to search one of the following verses to find what Jesus Christ suffered: Mosiah 3:7; Mosiah 15:5; or Alma 7:11. Invite them to list on the board what they found and to think of times when they have felt some of these things. According to Alma 7:12, why did Jesus suffer all of this? Why is it important to know He suffered these things for us?
- Sing together a hymn about the Savior, such as "I Know That My Redeemer Lives" (*Hymns*, no. 136). Invite the children to search the hymn for phrases that describe how the Savior comforts us, and talk about why these phrases are meaningful to them. Share your feelings about Jesus Christ, and invite the children to share theirs.



Encourage Learning at Home

Invite the children to look for someone this week who needs comfort. Encourage them to share with this person what they learned about the Savior taking upon Himself our pain so He could comfort us.

Improving Our Teaching

Invite sharing. Ask the children about their thoughts, feelings, and experiences. You'll find that they often have simple yet profound insights.

**Book of Mormon prophets taught about Jesus Christ's mission.
(1 Nephi 11:27; Mosiah 3:5, 15:7; Helaman 14:16-17).**

Draw a line from the Book of Mormon prophet to what he prophesied.

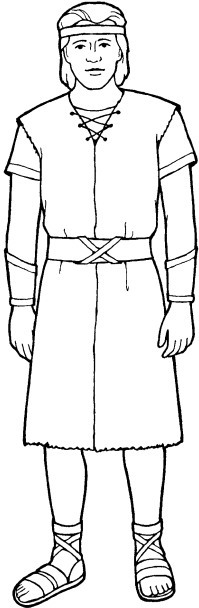

Nephi



Abinadi

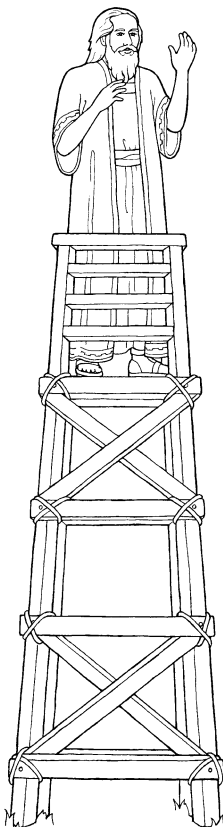
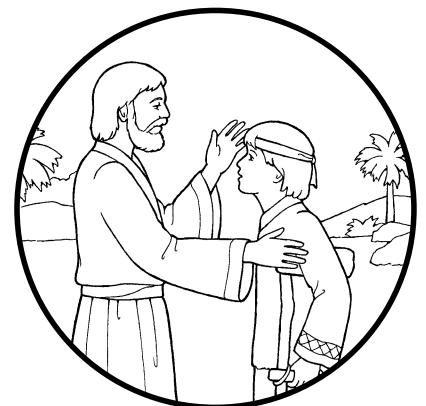
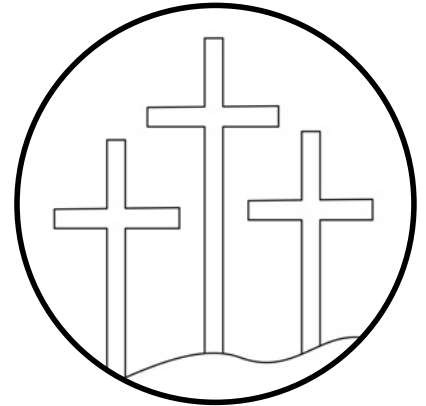
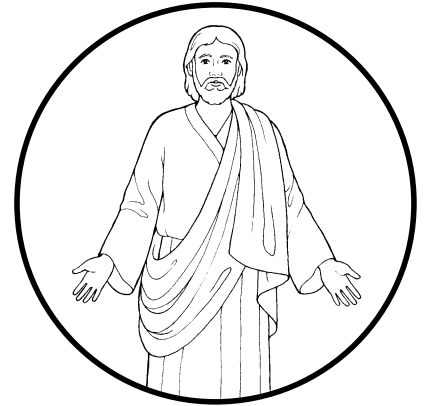

King Benjamin

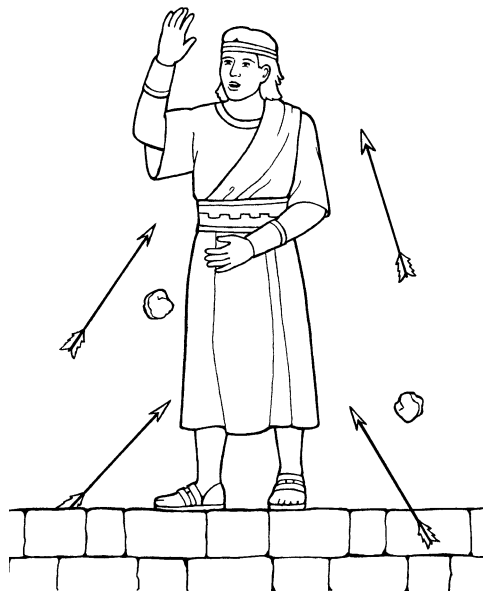

Samuel the Lamanite



Minerva K. Teichert (1888–1976), *King Benjamin's Farewell Address*, 1935, oil on masonite, 36 x 48 inches, Brigham Young University of Art

APRIL 13–19

Mosiah 1–3

“FILLED WITH LOVE TOWARDS GOD AND ALL MEN”

As you read Mosiah 1–3, pray to know how you can help the children you teach understand the important truths King Benjamin taught. Record the insights that come to you from the Holy Ghost.

RECORD YOUR IMPRESSIONS _____



Invite Sharing

Show the picture of King Benjamin teaching, found in this week’s outline in *Come, Follow Me—For Individuals and Families*. Ask the children to share what they know about this picture.



Teach the Doctrine: Younger Children

MOSIAH 2–3

When I serve others, rving God.

What will you do to help the children understand that serving others is also a way to serve God?

Possible Activities

- Let the children take turns wearing a crown (this week’s activity page has an example) and

standing on a chair or stool to pretend to be King Benjamin. They can do this while you share some of the things that King Benjamin taught his people, found in Mosiah 2–3. See also “Chapter 12: King Benjamin” (*Book of Mormon Stories*, 32–35, or the corresponding video on ChurchofJesusChrist.org).

- Invite the children to repeat the following sentence a few words at a time as they clap each syllable with you: “When ye are in the service of your fellow beings ye are only in the service of your God” (Mosiah 2:17). Repeat this until the children have learned some or all of the words. Testify that when we help others, we are also helping Heavenly Father and Jesus and making Them happy. Ask the children to share ways they can help others.
- Help the children trace their hands on a piece of paper and draw something they can do to serve their families. Sing together a song about service, such as “When We’re Helping” (*Children’s Songbook*, 198).



King Benjamin taught that we can serve God by serving others.

MOSIAH 2:19–25

All of my blessings come from Heavenly Father.

As the children recognize God as the source of all their blessings, they will be humble and thankful.

Possible Activities

- Explain that King Benjamin taught that all of our blessings come from Heavenly Father. Invite the children to listen for a blessing Heavenly Father has given us as you read Mosiah 2:21. What other blessings has Heavenly Father given us? How can we show that we are thankful for these things? (see Mosiah 2:22).
- Play a game in which the children pass around an object as they sing a song about gratitude or listen to one (see “Gratitude” in the topics index of the *Children’s Songbook*). Stop singing or stop the music periodically, and invite whoever is holding the object to share a blessing he or she is grateful for.

MOSIAH 3:1–20

I believe in Jesus Christ.

An angel told King Benjamin important truths about the life and ministry of Jesus Christ. Look in these verses for truths about Jesus that you feel are important for the children to learn.

Possible Activities

- Display pictures of some of the events mentioned in Mosiah 3:5–10 (see, for instance, *Gospel Art Book*, nos. 30, 41, 42, 57, 59). Ask the children what is happening in the pictures, and help them as needed. Slowly read Mosiah 3:5–10, and invite the children to raise their hands when you read about something in one of the pictures. Invite the children to share other things that they know Jesus did when He was on earth.
- Draw a sun at the top of the board to represent heaven. Draw several paths that lead to different places around the board but only one path that leads to heaven. Ask the children to find that path and place a picture of Jesus on it. Read Mosiah 3:17, and testify that following Jesus Christ is the only way to return to Heavenly Father.



Teach the Doctrine: Older Children

MOSIAH 2:11–18

When I serve others, I am also serving God.

How can you help the children learn from King Benjamin’s example of service?

Possible Activities

- Show the children a picture of King Benjamin teaching his people (see this week’s outline in *Come, Follow Me—For Individuals and Families or Gospel Art Book*, no. 74). Help the children search Mosiah 2:11–18 to find out what King Benjamin did to serve. Why did he serve his people? Why should we serve each other?
- Write on the board phrases from Mosiah 2:16–17 with some words missing. Invite the children to look in the scriptures for the missing words.

Ask them to explain what these verses mean to them. Invite them to share experiences when others have served them or they have served others. How did these experiences make them feel?

- Give the children strips of paper to write down ways they can serve their family members, and give each child a bag to place the papers in. Encourage the children to pick a strip of paper out of the bag each day and do that act of service for someone.

MOSIAH 2:15-24

I should not boast about my service and my good works.

Think about how you can help the children you teach understand that our service should be inspired by our love for others and for God.

Possible Activities

- Invite the children to share how they would define the word *boast*, or help them find the definition in a dictionary. Help them search Mosiah 2:15-24, looking for reasons why King Benjamin did not boast about his service to others. Why should we serve others? After the children share their ideas, help them understand that we should seek to serve others because we love them and God, not so that we will look good to others.
- Ask the children to share situations in which someone might boast or brag about something. Why is it wrong to boast in those situations? Invite them to use counsel from King Benjamin's speech in Mosiah 2:15-24 to help them with their answers.

MOSIAH 3:19

Jesus Christ cleanses me from sin and helps me become a saint.

In order to become like our Heavenly Father, we need more than cleansing from our sins—our hearts must change. As King Benjamin taught, we need to overcome our sinful desires and become saints through the Savior's Atonement.

Possible Activities

- Draw two people on the board—one to represent the “natural man” and another to represent a “saint.” (You may need to define these terms.) Read together Mosiah 3:19, and invite the children to find changes that the natural man needs to make in order to become a saint. What other words and phrases might the children need help understanding?
- Have the children you teach ever helped their parents prepare food using a recipe? If so, you might invite them to use Mosiah 3:19 to come up with a “recipe” for how we can become like Jesus Christ. Why is the Atonement of Jesus Christ the most important “ingredient”?



Encourage Learning at Home

Invite the children to use this week's activity page to share with their families or friends how they are going to follow King Benjamin's example and serve others.

Improving Our Teaching

Children benefit from repetition. Don't be afraid to repeat activities multiple times, especially with younger children. Repetition will help the children remember what they learn.

When I serve others I serve God (Mosiah 2-3).

In the triangles on the crown, draw ways you can serve others like King Benjamin did.
Cut out the pieces and make a crown that you can wear as you serve others.

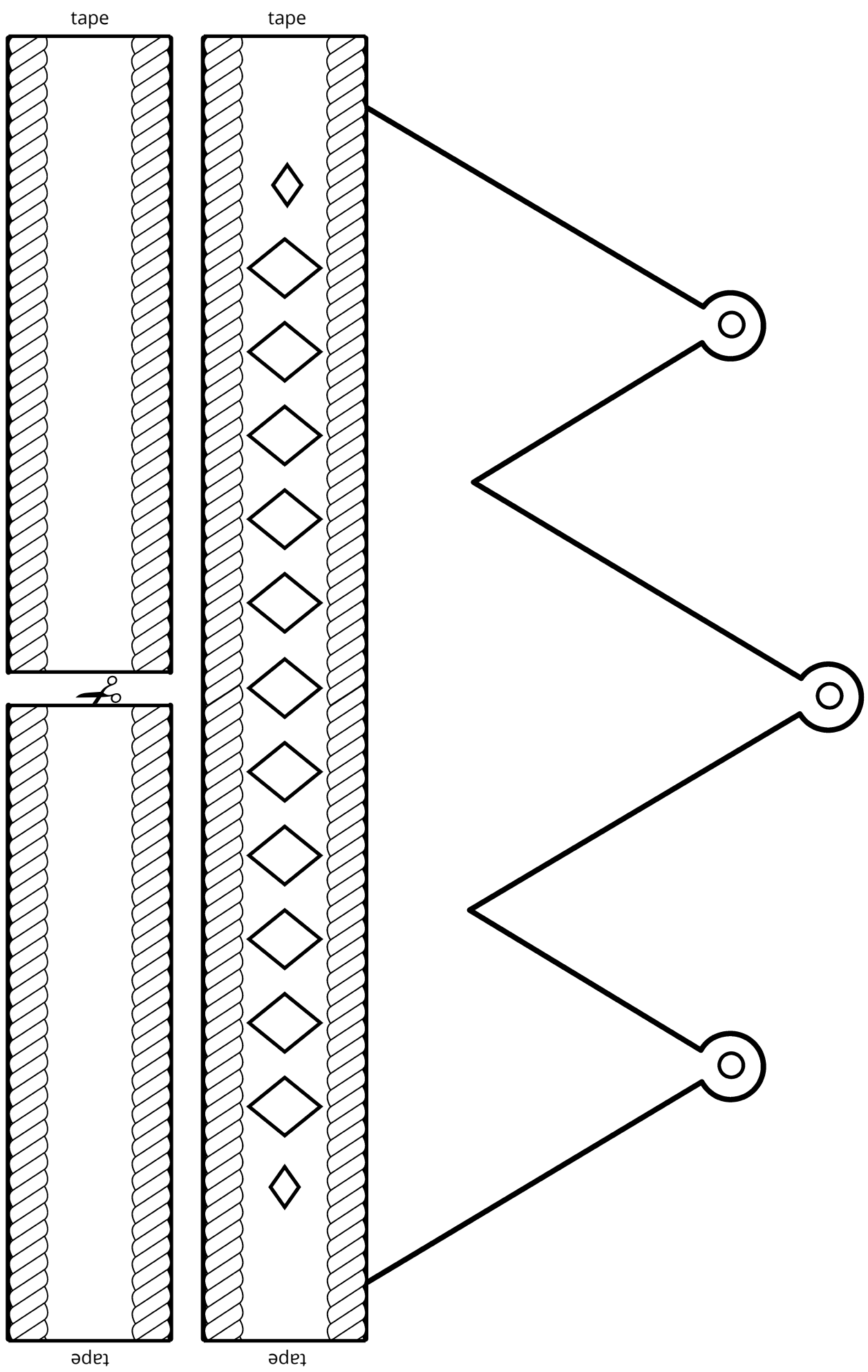



In the Service of Your God, by Walter Rame

APRIL 20–26

Mosiah 4–6

“A MIGHTY CHANGE”

Which of King Benjamin’s teachings in Mosiah 4–6 will best help the children you teach begin to experience “a mighty change” (Mosiah 5:2) in their hearts? Record your impressions as you prayerfully seek guidance.

RECORD YOUR IMPRESSIONS _____



Invite Sharing

Write the name of each child in your class on a strip of paper, and place the strips in a container. As you draw each name from the container, invite that child to share something they remember from last week’s lesson or something they learned from Mosiah 4–6 at home this week.



Teach the Doctrine: Younger Children

MOSIAH 4:1–3, 10

Repentance brings joy.

Help the children learn about the wonderful gift of repentance that is available because of the Atonement of Jesus Christ.

Possible Activities

- Use Mosiah 4:1–3 and 10 to teach the children what it means to repent. For example, help them discover that King Benjamin’s people felt sorry about their sins and asked for forgiveness (verses 1–2), and King Benjamin told them to forsake (or stop doing) their sins (verse 10). Read verse 3 to them, and ask how the people felt when they repented.
- Ask the children how it feels when we get our clothes dirty. How do we feel when we become clean again? Explain that like washing dirty clothes, we can repent when we make a mistake. Show a picture of Jesus Christ, and testify that He has the power to remove our sins and make us clean again if we repent. Sing together the second verse of “Help Me, Dear Father” (*Children’s Songbook*, 99). Ask the children what the song teaches about repentance.

MOSIAH 4:13–26**I should treat others with love and kindness.**

How can you use Mosiah 4:13–26 to teach the children “to love one another, and to serve one another”? (verse 15).

Possible Activities

- Draw a small heart on the board. Invite the children to share ways they can be kind to others. Each time they share, erase the heart and draw a bigger one. Testify that our love for others grows as we are kind to them. Give the children paper hearts, and invite them to draw on the hearts ways they can show love and be kind.
- Help the children come up with actions to do as they sing a song about loving others, such as “Jesus Said Love Everyone” or “Love One Another” (*Children’s Songbook*, 61, 136).

MOSIAH 5:5–15**When I make covenants with God, I take upon myself the name of Christ.**

Ponder how you can help the children you teach prepare to make baptismal covenants with God and to be “called the children of Christ” (Mosiah 5:7).

Possible Activities

- Help the children create badges displaying the name “Jesus Christ” and attach them to their shirts over their hearts (see this week’s activity page). Explain that King Benjamin taught his people that when we make covenants, or promises, with God, it’s like having the name of Christ “written always in [our] hearts” (Mosiah 5:12). What do we promise to do when we are baptized and take the sacrament? (see Mosiah 5:8; D&C 20:37, 77, 79).
- Ask the children what they would do to become friends with someone (for example, talk with them, do things with them, and spend time with

them). Read Mosiah 5:13 to the children. What can we do to come to know Jesus Christ better so He’s not a “stranger” to us?

**Teach the Doctrine:
Older Children****MOSIAH 4:1–11****I can repent.**

How can you help the children understand what it means to repent? Which verses in Mosiah 4:1–11 do you feel will help them?

Possible Activities

- Write the word *forgiveness* on the board. Read together Mosiah 4:1–3, and ask the children to search for words in verse 3 that describe the blessings that come when we repent and receive forgiveness.
- Ask the children to name things we must do in order to fully and sincerely repent. Help them find some of these things in Mosiah 4:10, and discuss the meanings of words and phrases found in that verse. Share a story that illustrates repentance, perhaps from your own life or from a recent Church magazine.
- Help the children find words in Mosiah 4:6, 9, and 11 that describe Heavenly Father. Why is it important to understand what Heavenly Father is like when we need to repent? Share your testimony of how you have felt God’s love as you’ve repented.

MOSIAH 4:12–26**The gospel inspires me to treat others with love and kindness.**

King Benjamin taught that when we come unto Christ and receive a remission of our sins, we are

“filled with the love of God” (Mosiah 4:12), which leads us to be loving and kind toward others.

Possible Activities

- Help the children search Mosiah 4:13–16, 26 and identify phrases that describe how we can serve others. Invite them to act out these things or draw pictures of them, and let the other children guess the phrase. How can we show love and kindness at home, at school, or at church?
- Invite the children to share an experience in which they loved or served someone and how that experience made them feel. What are some reasons people might not want to serve others? Ask the children what they would say to someone to persuade them to help people in need. They can find ideas in Mosiah 4:16–26.



Jesus Christ taught us to be kind to others.

MOSIAH 5:5–15

When I am baptized and take the sacrament, I take upon myself the name of Christ.

Many of the children you teach have probably been baptized and are renewing their covenants through the sacrament. Remind them that an important part of their baptismal covenant is taking upon themselves the name of Jesus Christ.

Possible Activities

- Draw a circle on the board, and place a picture of Jesus Christ in the center of the circle. Invite the children to draw pictures of themselves as you read Mosiah 5:8 together. What does this verse say we should take upon ourselves? What have we “entered into”? Invite the children to write Christ’s name on the pictures of themselves and place the pictures in the circle with the Savior. What covenants do we make when we are baptized and take the sacrament? (see Mosiah 18:8–9; D&C 20:77, 79).
- Talk to the children about why people put their names on things, such as school assignments, sports jerseys, and so on (see Mosiah 5:14–15). How can we show that we have Christ’s name “written always in [our] hearts”? (Mosiah 5:12).
- Invite a young man or woman from the ward to visit your class and explain the covenants we renew by partaking of the sacrament. Read the sacrament prayers in Doctrine and Covenants 20:77 and 79 with the children, inviting them to look for phrases that describe what we covenant to do and what God promises us in return.



Encourage Learning at Home

Invite the children to draw something they learned today and use their drawing to teach their families.

Improving Our Teaching

Teach children to record impressions. Even children can learn the habit of recording spiritual impressions—for example, by marking scriptures, drawing pictures, or writing simple journal entries.

When I make covenants with God, I take upon myself the name of Christ (Mosiah 5:5-15).

Color and write your name on one of the badges. Cut out the badge and wear it as a reminder that you are a disciple of Jesus Christ.

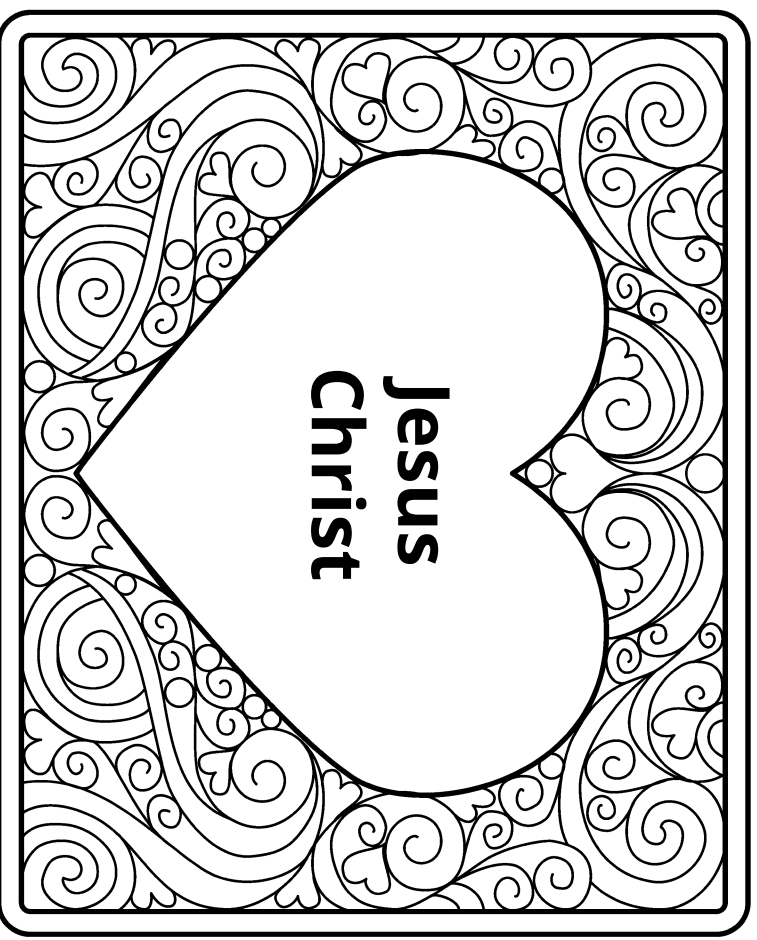
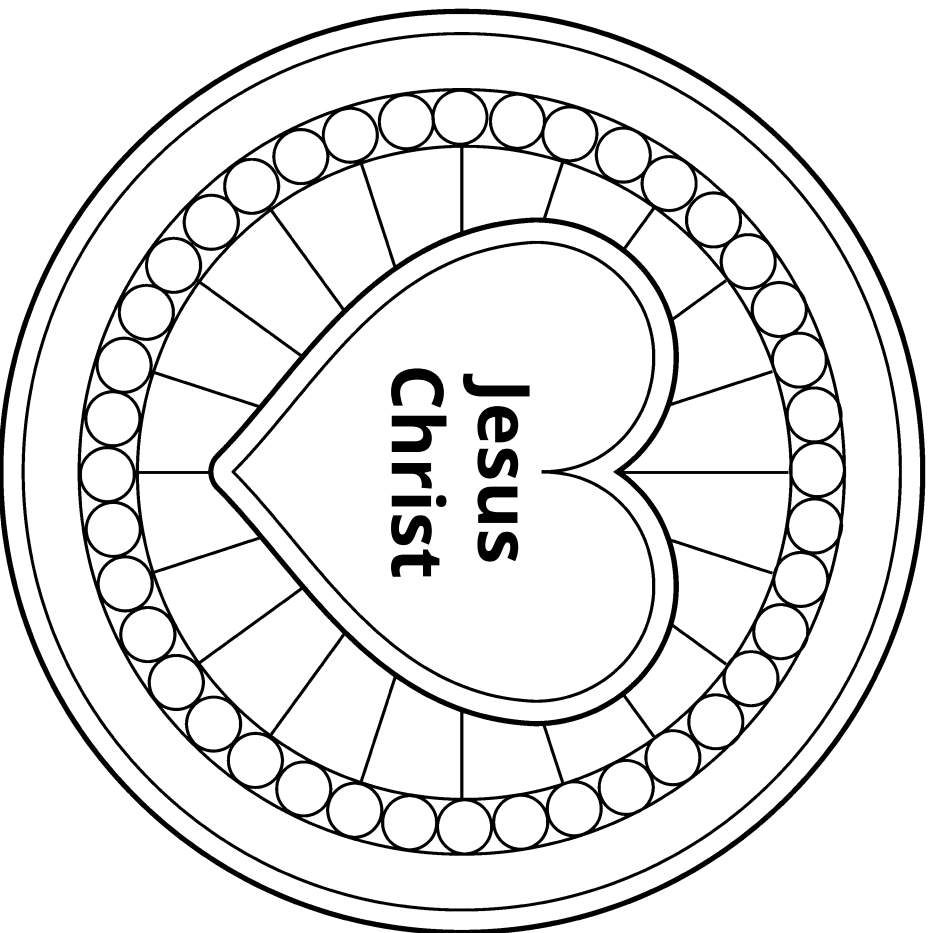



Minerva Teichert (1888–1976), *Ammon Before King Limhi*, 1949–1951, oil on masonite, 35 1/5/16 x 48 inches, Brigham Young University Museum of Art, 1969.

APRIL 27–MAY 3

Mosiah 7–10

“IN THE STRENGTH OF THE LORD”

Prayerfully read Mosiah 7–10, pondering the impressions you receive. How can the truths in these chapters help meet the needs of the children you teach?

RECORD YOUR IMPRESSIONS _____



Invite Sharing

Encourage the children to share anything they might know about the events in these chapters. You might find help in “Chapter 13: Zeniff” (*Book of Mormon Stories*, 36–37, or the corresponding video on ChurchofJesusChrist.org).



Teach the Doctrine: Younger Children

MOSIAH 7:18–20, 33

**God helped people in the scriptures,
and He can help me.**

Limhi’s people, who were in slavery to the Lamanites, needed faith that God would help them, so Limhi reminded them of times when God helped His people.

Possible Activities

- Ask the children to share a time when they needed help. Explain that King Limhi’s people were in trouble, so he shared a story to help them have faith. Read Mosiah 7:19 to the children, and show a picture of the children of Israel crossing the Red Sea (see *Moses Parting the Red Sea*, ChurchofJesusChrist.org). Review this story and the story of the manna, and help the children act out the stories (see chapters 17 and 18 in *Old Testament Stories*, or the corresponding videos on ChurchofJesusChrist.org). How did the Lord help the people? Testify that the Lord can also help us.
- Read Mosiah 7:33 to the children, and help them understand what the verse teaches us to do to receive help from the Lord. Help the children think of actions to represent these things, and repeat the verse while they do the actions. What are some things we need help with? How can we show that we trust the Lord? Share an experience when you trusted the Lord and He helped you.
- Select some verses of “Book of Mormon Stories” or “Nephi’s Courage” (*Children’s Songbook*,

118–19, 120–21) to sing with the children. Help them identify how the Lord helped people in the Book of Mormon. Share other scripture stories that you feel would help the children learn to trust the Lord.

MOSIAH 8:16–17

God has given us prophets, seers, and revelators.

How can you use Mosiah 8:16–17 to teach the children about a prophet’s role as a seer?

Possible Activities

- Show the children how to hold their hands up to their eyes as if they were looking through glasses or binoculars. Read Mosiah 8:17, and ask the children to put on their “glasses” each time they hear the word “seer.” Explain that God has given us prophets and that one of the roles of a prophet is to be a “seer” because he can “see” things to come. Share some examples of things that prophets have seen and revealed to us (including the scriptures), or share an example of when a prophet was acting as a seer (such as 1 Nephi 11:20–21).
- Make paper footprints, and draw on them pictures of things that prophets have counseled us to do. Place these footprints in a path around the room, and describe the pictures. Let the children take turns acting as a prophet and guiding the other children in following these footprints.
- Display the picture in this week’s outline in *Come, Follow Me—For Individuals and Families*, and ask the children to describe what they see. Explain that the Prophet Joseph Smith was a seer. The Lord gave him tools called the Urim and Thummim and a seer stone to use in translating the Book of Mormon.

- Show a short clip of a recent conference message from the President of the Church (or show a picture of him and read something he has taught). Bear your testimony that he is a prophet, seer, and revelator.



Teach the Doctrine: Older Children

MOSIAH 7:18–20, 33; 9:14–19; 10:6–10, 19–21

God helped people in the scriptures, and He can help me.

Zeniff and his people, who had settled in the Lamanites’ land, were being attacked by the Lamanites and needed God’s help. What can the children learn from this story about God helping His children?

Possible Activities

- Divide the children into three groups, and invite each group to study one of the following scripture stories: the Israelites crossing the Red Sea (see Exodus 14:10–14, 21–31), Lehi’s family traveling in the wilderness (see 1 Nephi 16:9–16; 17:1–6), and Zeniff’s people being delivered from the Lamanites (see Mosiah 9:14–19; 10:6–10, 19–21). How did the people in these stories show that they trusted in God? How did God help them? How does He help us when we trust Him?
- Invite three children to write a trial or challenge they face on the board. Ask a child to read Mosiah 7:33, and encourage the other children to erase one of the trials or challenges each time they hear something they can do to receive the Lord’s help. How can trusting in the Lord help us overcome our challenges?

MOSIAH 8:12–19**God provides prophets, seers, and revelators to benefit mankind.**

We sustain the First Presidency and the Twelve Apostles as prophets, seers, and revelators. How can you teach the children about the value of prophets?

Possible Activities

- Select several important words from Mosiah 8:12–19, and write them on the board. Invite a child to read these verses, and ask the other children to raise their hands when they hear each word on the board. Stop the reading and discuss each word as a class.
- Ask the children to review Mosiah 8:16–18 to learn what a seer is. Write this sentence on the board: *A seer is like _____*. Help the children think of ways to complete the sentence to explain why a seer is a blessing to us—for example, a seer is like a life-guard, who warns us of danger.
- Pick a phrase from Mosiah 8:16–17, and write it on the board, replacing each word with a made-up symbol. Give the children a list of the symbols and the words they represent, and let them decode or “translate” the phrase as seers do. What are some other ways that prophets, seers, and revelators are “a great benefit” to us? (Mosiah 8:18).

MOSIAH 9:14–18; 10:10–11**When I am weak, the Lord can strengthen me.**

When children face challenges, they sometimes feel weak and helpless. Use the account of Zeniff’s

people to teach the children that they can receive strength from the Lord.

Possible Activities

- Ask the children to share ways they can become physically strong. What does it mean to have “the strength of men”? (see Mosiah 10:11). What does it mean to have “the strength of the Lord”? (see Mosiah 9:17–18; 10:10). How do we receive the strength of the Lord?
- Invite the children to draw a picture of someone who they feel has the strength of the Lord and share why they drew this person.

**Encourage Learning at Home**

Invite the children to share with their families a story from the scriptures that inspires them to “put [their] trust in God” (Mosiah 7:19).

Improving Our Teaching

Ask inspired questions. Ask questions that invite the children to share their testimonies of gospel truths. For example, if you are discussing prophets, you could ask the children to share how prophets have blessed them.

The Lord provides prophets, seers, and revelators to benefit mankind (Mosiah 8:12-19).

Joseph Smith was a seer. Connect the dots and color the picture.





Abinadi before King Noah, by Andrew Bosley

MAY 4-10

Mosiah 11-17

“A LIGHT . . . THAT CAN NEVER BE DARKENED”

Ponder and pray to know how you can use the story of Abinadi and his teachings in Mosiah 11-17 to help the children you teach. Record the impressions you receive.

RECORD YOUR IMPRESSIONS _____



Invite Sharing

Allow the children to share what they know about the story of Abinadi and King Noah. The picture in this week’s outline in *Come, Follow Me—For Individuals and Families* could help.



Teach the Doctrine: Younger Children

MOSIAH 11-13; 17

I can stand for truth, even when I stand alone.

Both Abinadi and Alma were courageous in defending the truth. How can you use this story to build the children’s courage for moments when they may have to defend their beliefs?

Possible Activities

- Summarize the account of Abinadi, King Noah, and Alma found in Mosiah 11-13 and 17. You might use “Chapter 14: Abinadi and King Noah” (*Book of Mormon Stories*, 38-42, or the corresponding video on ChurchofJesusChrist.org). Invite the children to act out the account, giving them turns to play different roles.
- March in place with the children as they sing a song that inspires courage, such as “I Will Be Valiant” (*Children’s Songbook*, 162). Read the words of the song together, and help the children identify what a valiant or courageous person does. Select a few verses from Mosiah 11-13 and 17 to read to the children to show how Abinadi and Alma were valiant (for example, see Mosiah 13:1-4, 9).

MOSIAH 12:33-36; 13:11-24

I should obey the Ten Commandments.

King Noah’s priests knew the commandments but did not follow them. Abinadi’s words can help the children understand the importance of obeying the commandments.

Possible Activities

- Invite the children to count to 10. Or give them 10 numbered pieces of paper and let them put the papers in order. Explain that Heavenly Father gave us Ten Commandments to help us return to live with Him. Help the children recite with you some of the Ten Commandments from Mosiah 12:33–36 and 13:11–24.
- Show a picture of Moses with the Ten Commandments (such as *Gospel Art Book*, no. 14), and briefly explain how Moses received the commandments from God (see Exodus 19–20). Then show a picture of Abinadi (see this week’s outline in *Come, Follow Me—For Individuals and Families*), and tell the children that Abinadi reminded King Noah and his priests about the Ten Commandments. Choose a few of the commandments from Mosiah 12:33–36 and 13:11–24 that you feel are particularly important for the children you teach, and discuss with them the blessings that come from obeying those commandments.
- Sing together a song about commandments, such as “Keep the Commandments” (*Children’s Songbook*, 146–47). Why do we keep the commandments?

MOSIAH 14:5; 15:7–9

Prophets bravely testify of Jesus Christ.

Abinadi taught King Noah and others about Jesus Christ, even when it was dangerous. How can Abinadi’s account strengthen the children’s testimonies of prophets?

Possible Activities

- Share with the children some of the things Abinadi taught about Jesus Christ in Mosiah 14:5 and 15:7–9. Help the children understand that Abinadi wanted King Noah and his people to follow Jesus so they could be happy. In our day, living prophets teach us about the Savior. Read an excerpt from general conference, or share

a video clip of one of the living prophets sharing his testimony of Jesus Christ (for example, see the “Special Witnesses of Christ” videos on ChurchofJesusChrist.org).

- Show or draw pictures of chains, a jail, and a fire. Teach the children that Abinadi was willing to be tied up, put in jail, and even burned by fire to share his testimony of Jesus Christ. Even though we will probably never face these dangers, how can we be courageous like Abinadi in sharing our testimonies with both our words and our choices?



Teach the Doctrine: Older Children

MOSIAH 11–13; 17

I can stand for the right, even when I stand alone.

How can you prepare the children you teach to courageously stand for the right, even if they must do so alone?

Possible Activities

- Invite the children to draw pictures of different parts of the account of Abinadi, King Noah, and Alma found in Mosiah 11–13 and 17. Help them use their pictures to retell the story, or use “Chapter 14: Abinadi and King Noah” (*Book of Mormon Stories*, 38–42, or the corresponding video on ChurchofJesusChrist.org). How did Abinadi and Alma each stand for the right? Why didn’t King Noah stand for the right? (see Mosiah 17:11–12). Help the children think of times when they stood up for what’s right.
- Help the children think of scenarios in which they could stand for the right, and invite them to role-play some of these situations. For example,

what could they do when someone tries to get them to watch an inappropriate movie or when their friends don't want to include someone in a game they are playing?

- Show the video “Dare to Stand Alone” (ChurchofJesusChrist.org). How was President Thomas S. Monson like Abinadi?

MOSIAH 12:33–36; 13:11–24

I should obey the Ten Commandments.

Abinadi taught King Noah and his wicked priests about the Ten Commandments. Do the children you teach understand why we should love and obey God's commandments?

Possible Activities

- Assign each child to read one of the commandments in Mosiah 12:35 and 13:11–24. Help the children think of creative ways to help each other remember each commandment (such as a rhyming phrase, an action, or an acronym). The song “The Commandments” (*Children's Songbook*, 112–13) can also help. Give the children heart-shaped pieces of paper, and invite them to write one or more of the Ten Commandments on their hearts (see Mosiah 13:11)—perhaps one they feel they should try harder to obey.



The scriptures teach us God's commandments.

- Sing together a song about the commandments, such as “Keep the Commandments” (*Children's Songbook*, 146–47). What blessings come from keeping the commandments?

MOSIAH 14:6; 16:4–9

When I sin, I become lost; because of Jesus Christ, I can be found.

To teach about Jesus Christ, Abinadi quoted the prophet Isaiah, who compared us to lost sheep. How can you use this comparison to teach the children about the Savior?

Possible Activities

- Invite the children to share experiences when they lost something or were lost themselves. How did they feel? What did they do? Read together Mosiah 14:6 and 16:4–9. How do we sometimes go “astray” from God? How does Jesus Christ help us come back?
- Invite the children to imagine a herd of sheep. What are some reasons one of the sheep might get lost? List their answers on the board. How are we like sheep who wander? How might Heavenly Father feel when we are “found” through repentance and the Savior's Atonement? (see D&C 18:10–13). Share your testimony of the Savior and of repentance.



Encourage Learning at Home

Invite the children to ask their family members to share experiences in which they stood for truth, or encourage the children to share their own experiences.

Improving Our Teaching

Repetition is key to learning. Children benefit from hearing a gospel principle or doing an activity more than once. Try repeating activities in a variety of ways.

I can stand for truth, even when I stand alone (Mosiah 11-13; 17).

Use the illustration to make a card in which Abinadi "stands up" when you open it. Draw or write a way you can stand for what is right on the back of the card.

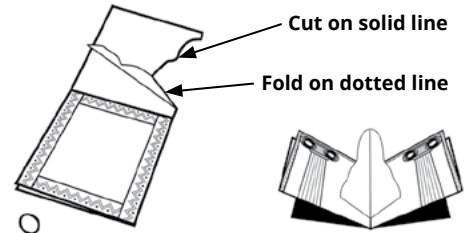

fold in center



fold in center

fold in center

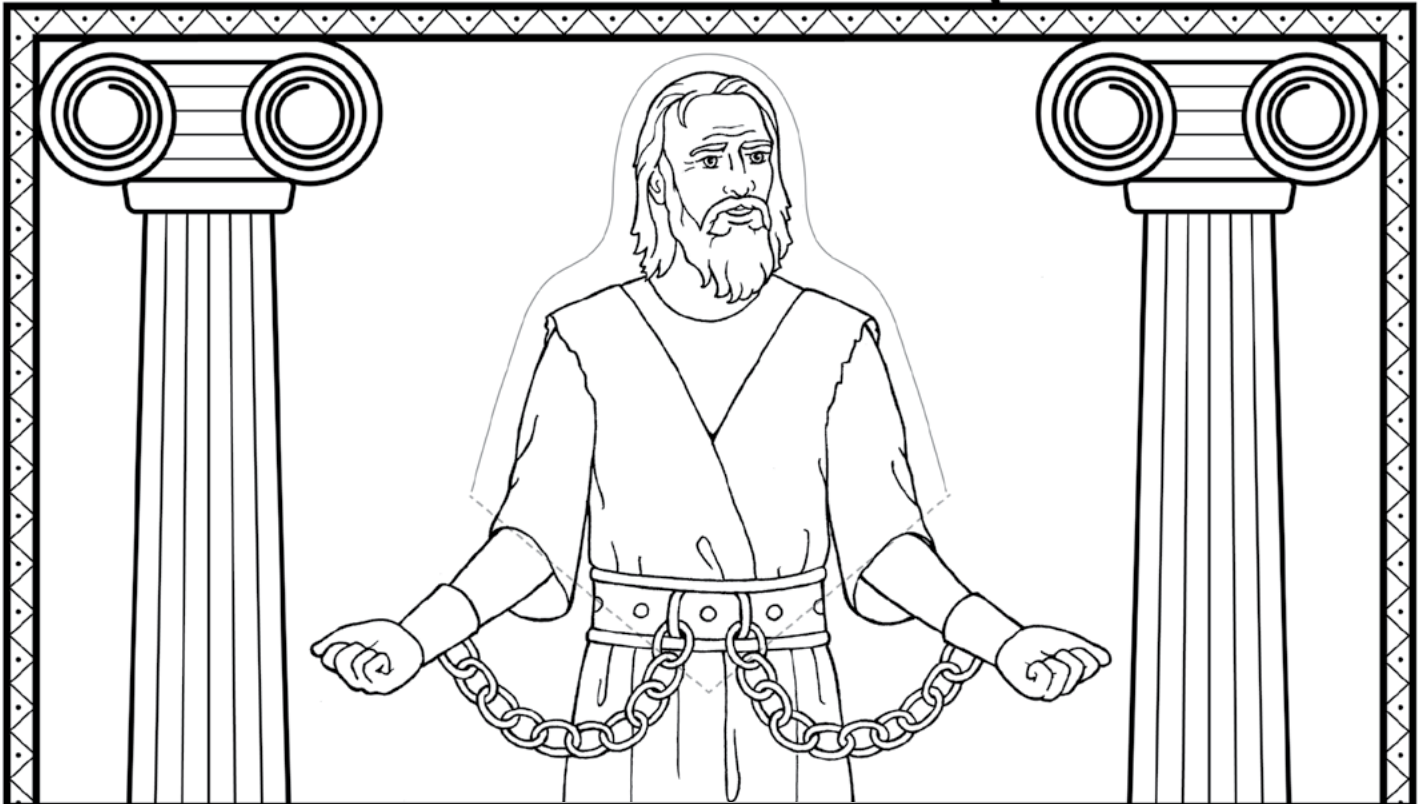

Abinadi!
stood for
what was right.

This is how I can stand
for what is right:

fold in center



Minerva Teichert (1888–1976), *Escape of King Limhi and His People*, 1949–1951, oil on masonite, 35 7/8 x 48 inches. Brigham Young University Museum of Art, 1969.

MAY 11–17

Mosiah 18–24

WE HAVE ENTERED INTO A COVENANT WITH HIM

As you read Mosiah 18–24, think about the children you teach. The Holy Ghost can help you identify truths that will be relevant to them.

RECORD YOUR IMPRESSIONS _____



Invite Sharing

Show a picture of someone being baptized, and invite the children to share something they know about baptism. They could share something they learned while reading Mosiah 18–24 with their families, while attending a baptism, or in another setting.



Teach the Doctrine: Younger Children

MOSIAH 18:7–16

When I am baptized, I make a covenant with God.

One of the most important ways to help children prepare for baptism is to teach them about the covenant they will make when they are baptized.

Possible Activities

- Review the story of Alma and his people at the Waters of Mormon using Mosiah 18:7–16 or “Chapter 15: Alma Teaches and Baptizes” (*Book of Mormon Stories*, 43–44, or the corresponding video on ChurchofJesusChrist.org). Show the picture in this week’s outline in *Come, Follow Me—For Individuals and Families*, and let the children tell you what they know about the story.
- Using Mosiah 18:8–10 as a guide, teach the children in your own words some of the things they will promise to do when they are baptized. For example, they will promise to follow Heavenly Father and Jesus by comforting people who are sad. Share a story of how you or someone you know has kept these promises. (See also D&C 20:77, 79; Carole M. Stephens, “We Have Great Reason to Rejoice,” *Ensign* or *Liahona*, Nov. 2013, 115–17.)
- Explain that when we are baptized, Heavenly Father also makes promises to us. Share these promises, as described in Mosiah 18:9–10.

MOSIAH 18:17–28**When I am baptized, I become a member of Jesus Christ’s Church.**

Help the children understand what it means to become members of the Church through baptism and confirmation.



We make a covenant with God when we are baptized.

Possible Activities

- Invite someone who has recently been baptized to share his or her experience. Read Mosiah 18:17, and explain that when we are baptized we become members of The Church of Jesus Christ of Latter-day Saints and promise to follow Jesus.
- Show the children pictures that represent things described in Mosiah 18:17–28. For example, the picture Ordination to the Priesthood (*Gospel Art Book*, no. 106) might represent verse 18, and the picture Payment of Tithing (*Gospel Art Book*, no. 113) could represent verses 27–28. Let the children describe what they see in the pictures, and use the pictures and the verses to help them see what it means to be a member of the Church.

MOSIAH 24:8–17**God can make my burdens light.**

When has God made your burdens feel light? Think of ways you can share your experiences and testimony with the children.

Possible Activities

- Help the children think of simple actions they can do while you tell what happened to Alma’s people in Mosiah 24:8–17. Point out that because Alma chose to follow Abinadi’s teachings about Jesus, he and his people were treated unkindly, but they never stopped believing in Jesus.
- Read Mosiah 24:14–15 to the children. Fill a bag with heavy objects (to represent burdens), and invite a child to hold the bag. Explain that when we are sad, sick, or have other troubles, it can feel like carrying something heavy. Invite the children to take turns helping the child carry the bag so that it becomes lighter. Explain that Heavenly Father can make our burdens lighter when we seek His help through prayer, serving others, and so on.

**Teach the Doctrine:
Older Children****MOSIAH 18:7–16****When I am baptized, I make a covenant with God.**

How can you help the children you teach understand the covenant we make at baptism?

Possible Activities

- Give each child a piece of paper. Read together Mosiah 18:8–10, and invite the children to write or draw on one side of their paper the promises we make at baptism and, on the other side, the blessings Heavenly Father promises us. Let them share with the class what they find. As they share, ask questions like these: How can we “mourn with those that mourn”? What does it mean to be a witness of God “in all places”? (verse 9). What can we do to keep our covenants?

- Invite several children who have been baptized to share what they remember about their experience. What made that day special? How did they feel? Explain that each Sunday they renew their baptismal covenant when they partake of the sacrament. Help the children compare the baptismal covenant described in Mosiah 18:8–10 with the sacrament prayers (see D&C 20:77, 79). How can we make the sacrament a special, reverent time, just like our baptisms were?
- Ask a recent convert to share how he or she learned about the Church and how it felt to be baptized. Let the children ask questions, such as what helped that person want to make the promises in Mosiah 18:7–16.

MOSIAH 18:17–28

I belong to The Church of Jesus Christ of Latter-day Saints.

How can you inspire the children to be grateful for the blessings of being members of the Church?

Possible Activities

- Invite the children to read Mosiah 18:17–28, looking for teachings of Christ’s Church in Alma’s day that are the same in our day. Write their answers on blocks or cups, and let the children use them to build a structure that represents the Church of Jesus Christ.
- Sing with the children or read the words to “The Church of Jesus Christ” (*Children’s Songbook*, 77), and invite them to listen for things that we promise to do as members of the Church. Help them think of ways they can keep these promises.

MOSIAH 21:1–5, 13–16; 22:1–11; 24:8–22

God can make my burdens light.

The story of Alma’s people can show the children that sometimes God helps by strengthening us to endure our trials instead of taking them away. How can you help them learn from this story?

Possible Activities

- Help the children identify main events from the accounts of Limhi’s people in Mosiah 21:1–5, 13–16; and 22:1–11 and Alma’s people in Mosiah 24:8–22. Then ask each child to draw one of these events. Invite the children to put their drawings in the correct order to tell the story. As they do, emphasize that God helped the people bear their burdens.
- Invite the children to read Mosiah 21:14–15 and 24:13–14. How did the Lord respond to the prayers of Limhi’s people and Alma’s people? Ask the children to share times when they prayed for help with a trial and Heavenly Father helped them, or share your own experience.



Encourage Learning at Home

Invite the children to explain to someone else what they will promise or have promised to do as part of their baptismal covenant.

Improving Our Teaching

Pay attention to the children. If the children seem restless, it may be time to try another activity or to take a short, reverent walk. On the other hand, if they are engaged and learning, don’t feel pressured to move on just to cover more lesson material.

When I am baptized, I make a covenant with God (Mosiah 18:8-10; see also D&C 20:77,79).

I promise

- To take upon myself the name of Jesus Christ.
- To serve God and others.
- To obey the commandments.
- To always remember Jesus.
- To stand as a witness of Jesus.

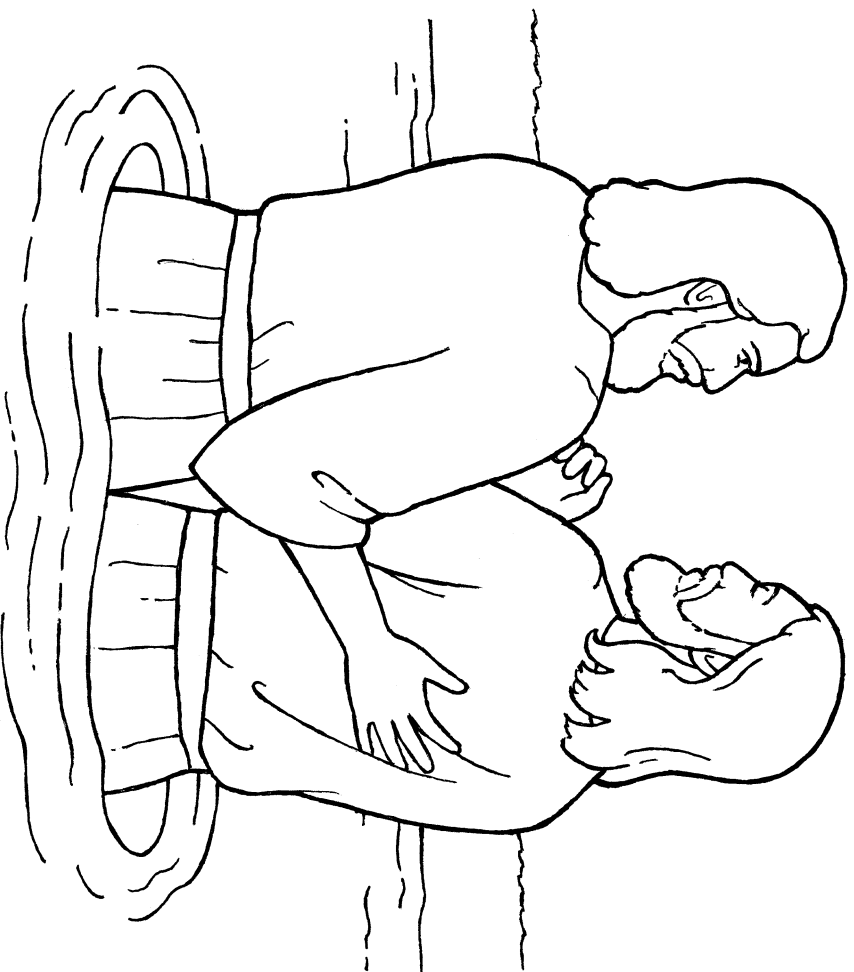

Heavenly Father promises

- To forgive me of my sins when I repent.
- To always have the Holy Ghost to be with me.
- That I can return to live with Him.



Conversion of Alma the Younger, by Gary L. Kapp

MAY 18-24

Mosiah 25-28

“THEY WERE CALLED THE PEOPLE OF GOD”

Heavenly Father knows what the children in your class need to learn and how to reach them. Seek His guidance as you read Mosiah 25-28 and review this outline.

RECORD YOUR IMPRESSIONS _____



Invite Sharing

Show the picture in this week’s outline in *Come, Follow Me—For Individuals and Families*, and ask the children to describe what is happening in the picture. If the children are familiar with the story of Alma the Younger and the sons of Mosiah, let them share what they know.



Teach the Doctrine: Younger Children

MOSIAH 26:30-31

The Lord wants me to forgive.

The Lord taught Alma that He freely forgives those who repent. We should follow His example by forgiving those who sin against us.

Possible Activities

- Read to the children this phrase from Mosiah 26:31: “Ye shall also forgive one another.” Let the children practice saying “I forgive you” a few times, and find out if they know what it means to forgive. Share an experience from your life when you forgave someone or someone forgave you.
- Help the children role-play forgiving one another. Ask one child to pretend that he or she has done something to hurt or offend another child. What can the other child say or do to show forgiveness?
- Invite the children to draw a sad face on one side of a paper and a happy face on the other side. Ask them to hold up the sad face while they tell about an experience when a sibling or friend made them upset. Ask them to hold up the happy face while they tell how they have forgiven or will forgive that person.

MOSIAH 27:8-37

The gospel helps people change and become more like Jesus.

The conversion of Alma the Younger and the sons of Mosiah demonstrates that because of Jesus Christ

and His gospel, anyone can change and become more like Jesus.

Possible Activities

- Briefly tell about the conversion of Alma the Younger and the sons of Mosiah, as described in Mosiah 27:8–37. For help, see “Chapter 18: Alma the Younger Repents” (*Book of Mormon Stories*, 49–52, or the corresponding video on ChurchofJesusChrist.org). Then tell the story again, allowing the children to share the details they remember. Let them act out the story, and help them see the differences between what Alma and the sons of Mosiah were like before they repented and afterward.
- Help the children use this week’s activity page to tell the story of Alma and the sons of Mosiah. Read Mosiah 27:24, and help the children understand that Alma and the sons of Mosiah changed because they repented of their sins and accepted the gospel of Jesus Christ.



His Father Rejoiced, by Walter Rane

MOSIAH 28:1–8

I can share the gospel.

After their conversion, the sons of Mosiah were eager to share the gospel with everyone, including their enemies, the Lamanites.

Possible Activities

- Use Mosiah 28:1–8 to tell the children about the sons of Mosiah deciding to preach the gospel to

the Lamanites. For help, see “Chapter 19: The Sons of Mosiah Become Missionaries” (*Book of Mormon Stories*, 53, or the corresponding video on ChurchofJesusChrist.org). Why did they want to share the gospel? (see verse 3).

- Help each child think of someone who needs to know more about the gospel. Help the children plan what they will say to the people they thought of.
- Sing together a song about sharing the gospel, such as “I Want to Be a Missionary Now” (*Children’s Songbook*, 168). Point out phrases in the song that suggest how we can share the gospel with others.



Teach the Doctrine: Older Children

MOSIAH 26:22–23, 29–30; 27:8–37

God freely forgives those who repent.

If anyone in your class wonders if he or she can truly be forgiven, God’s words to Alma the Elder and the experience of Alma the Younger can help.

Possible Activities

- Ask the children to pretend they are talking to someone who doesn’t think God will ever forgive him or her. Invite them to review God’s words to Alma the Elder in Mosiah 26:22–23, 29–30. What do they find that would help that person?
- Before class, ask one of the children to read about the conversion of Alma the Younger, found in Mosiah 27:8–37, and come prepared to tell the story to the class as if he or she were Alma the Younger. (If needed, suggest that he or she ask a parent to help.) As the child tells the story, ask

questions such as “How did you feel when . . . ?” or “What happened next?”

- Invite the children to make a list of words from Mosiah 27:8–10 that describe what Alma and the sons of Mosiah were like before their conversion. Then ask them to make another list from Mosiah 27:32–37 that describe what they were like afterward. According to verses 24–29, what caused this great change in Alma?

MOSIAH 26:29–31

To be forgiven, I must forgive.

Help the children see the connection between the forgiveness they extend to others and the forgiveness they hope for themselves.

Possible Activities

- Invite the children to read Mosiah 26:29–31 and count how many times the word “forgive” appears. What do these verses teach us about forgiving others? How does forgiveness help both the person who has done something wrong and the person who forgives?
- Ask a child to draw a bridge on the board, and share this statement quoted by President Thomas S. Monson: “He that cannot forgive others breaks the bridge over which he himself must pass if he would ever reach heaven, for everyone has need of forgiveness” (George Herbert, quoted in “Hidden Wedges,” *Ensign*, May 2002, 19). Erase part of the bridge, and ask the children to help you rebuild it, piece by piece, as they share ways they can extend forgiveness to others. Invite them to think of someone they need to forgive.

MOSIAH 27:8–24

I can pray and fast for God to bless those I love.

Consider how you can help the children understand that fasting can strengthen their faith as they pray for people they love.

Possible Activities

- Read together Mosiah 27:8–24, and ask the children to identify what Alma and his people did to help Alma the Younger. Share an experience in which you fasted and prayed for someone, and encourage the children to share their own experiences.
- Invite the children to think of someone they know who needs God’s help in his or her life. Bear your testimony that the children can pray and fast with faith for God to bless this person. Invite the children to pray for the person they thought of and, if they are able, fast for them too.



Encourage Learning at Home

Ask the children to pick one thing they learned from the experience of Alma the Younger and the sons of Mosiah that they would like to share with their families.

Improving Our Teaching

Support parents. “Parents are the most important gospel teachers for their children—they have both the main responsibility and the greatest power to influence their children (see Deuteronomy 6:6–7). As you teach children at church, prayerfully seek ways to support their parents” (*Teaching in the Savior’s Way*, 25).

The gospel helps people change and become more like Jesus (Mosiah 27:8-37).

Color the pictures and cut out the figure around the edges. Make a pyramid by folding the figure on the solid lines and taping or gluing the flap inside the pyramid. Use the pyramid to tell the story of how Alma changed.

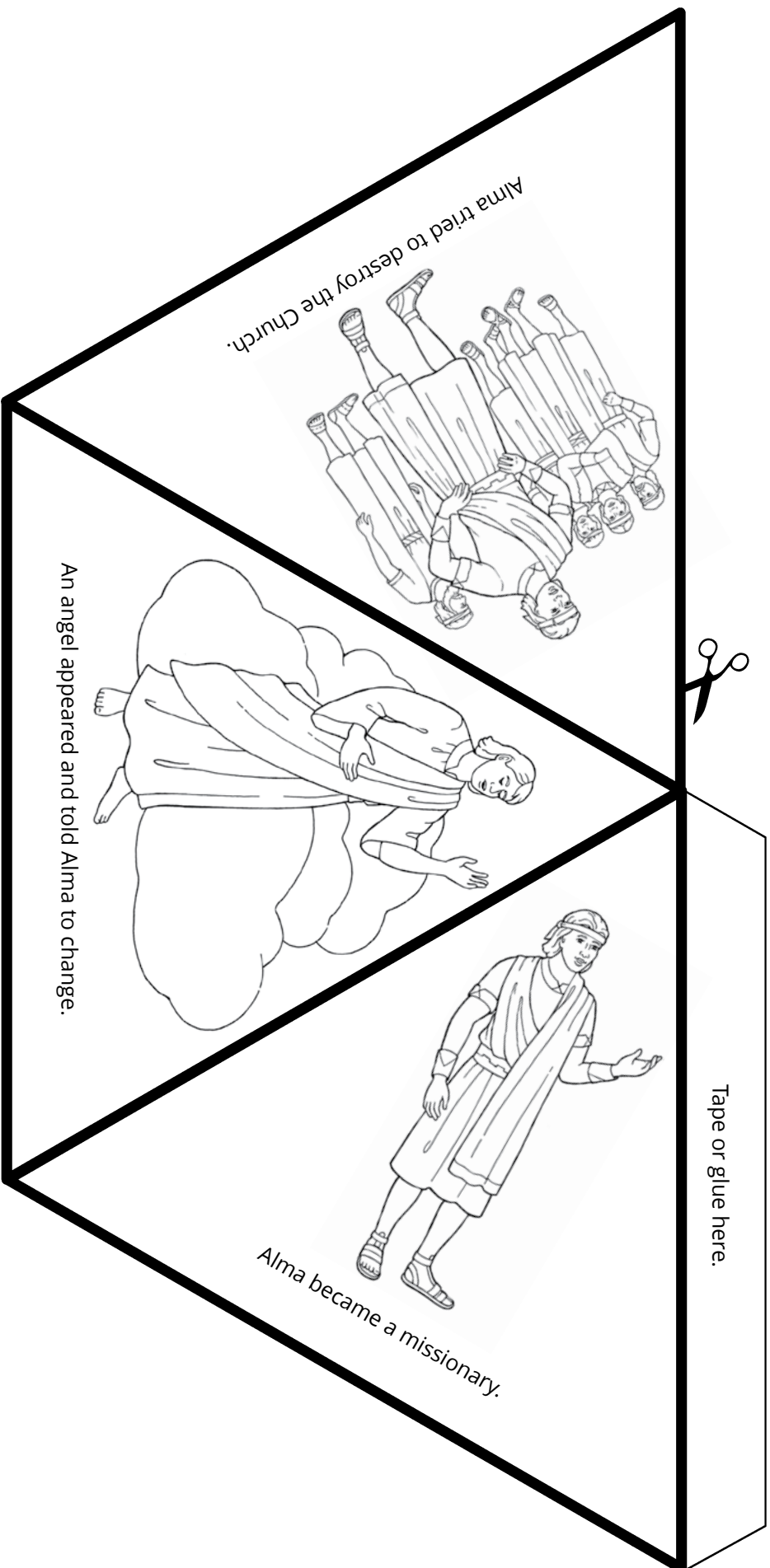



Alma the Younger Preaching, by Gary L. Kapp

MAY 25-31

Mosiah 29–Alma 4

“THEY WERE STEADFAST AND IMMOVABLE”

The children you teach can learn a lot in your class, but they’ll learn even more if they develop a habit of studying the scriptures at home. Consider how you can encourage and support gospel learning in the home.

RECORD YOUR IMPRESSIONS _____



Invite Sharing

Invite the children to sit on the floor in a circle, and roll a ball to one of them. Ask that child to share something he or she has learned recently about the gospel at home or in Primary. Then invite the child to roll the ball to someone else. Repeat until every child has had a chance to share something.



Teach the Doctrine: Younger Children

ALMA 1:2-9, 26-30

As a member of the Church, I should love and serve others.

You may not choose to tell the children much about Nehor’s teachings, but they might benefit

from knowing that in the Church we serve because we love others, not because we want to become rich or popular.

Possible Activities

- Share with the children, in simple terms, the story of Alma and Nehor (see Alma 1; “Chapter 20: Alma and Nehor,” *Book of Mormon Stories*, 54–55, or the corresponding video on ChurchofJesusChrist.org). Emphasize that even though Nehor’s followers were mean to the Church members, many of the Church members remained kind and loving.
- Read Alma 1:30 to the children, and help them understand that the people of the Church shared what they had with people who needed help. Help the children think of things they could share and people they could share them with. Encourage the children to draw pictures of their plans.
- Sing together a song about love and service, such as “Kindness Begins with Me” (*Children’s Songbook*, 145), and help the children think of actions that could go with the song.

ALMA 2:28–30**God will answer my prayers.**

When Alma and the Nephites felt “much fear” (Alma 2:23), they prayed for help and were strengthened. Help the children learn from their example.

Possible Activities

- Using pictures in this week’s outline in *Come, Follow Me—For Individuals and Families* or in “Chapter 21: The Amlicites” (*Book of Mormon Stories*, 56–57, or the corresponding video on ChurchofJesusChrist.org), tell the children how the Nephites gained strength to defeat the Amlicites. Ask the children about things that are scary or hard for them, and testify that they can pray to Heavenly Father for help with these things.
- Share an experience when God helped you after you prayed to Him. Invite the children to share experiences they have had with prayer.

ALMA 4:19**My testimony can strengthen others.**

Often the “pure testimony” (Alma 4:19) of a child can have a strong influence on others. How can you help the children find ways to share their testimonies?

Possible Activities

- Open the scriptures to Alma 4:19, and explain that when Alma saw how wicked the people were, he decided the best way to help them was to bear “pure testimony” to them. Use this week’s activity page to teach the children what a testimony is and what it includes. Encourage them to share their testimonies.
- Pour some clean water into a clear glass, and explain that the water is like our testimonies because we can share it with others. Pour the glass of water into a small cup for each child, and tell the children that when we share our testimonies, we help others have stronger testimonies too.

- If the children would like to, let them practice bearing their testimonies. Suggest several ways they can show they know the gospel is true, including through their actions.

**Teach the Doctrine:
Older Children****ALMA 1:2–9****I can learn to recognize false teachings.**

At some point in our lives, we all have to face people like Nehor—those who try to deceive us with messages that sound appealing but are false and harmful. Sharing the account in Alma 1:2–9 could help the children prepare for such encounters in their lives.

Possible Activities

- Help the children read Alma 1:2–4 to review some of the things that Nehor, a false teacher, taught. Help them create a true-or-false quiz using statements from these verses. Why does Satan sometimes combine truths with falsehoods? Help the children think of some examples.
- After reviewing Alma 1:2–9 together, ask each of the children to read one of the following scriptures: Matthew 7:21–23; 2 Nephi 26:29–31; Mosiah 18:24–26; and Helaman 12:23–26. How do these scriptures refute Nehor’s teachings? How can we use the scriptures to fortify our own testimonies of the gospel?

ALMA 1:26–30; 4:6–13**As a member of the Church, I should love and serve others.**

Sometimes the Church members in Alma’s day were generous and giving, and other times they were

unkind and prideful. Help the children you teach learn from their experiences.

Possible Activities

- Help the children read Alma 4:6–13, and define words like “scornful,” “persecute,” and “despising” (use a dictionary if necessary). How do we feel when people treat us in these ways? Invite the children to find words in Alma 1:26–30 that describe how Heavenly Father wants us to treat each other.
- Ask the children to read Alma 1:27, 30 and make a list of the kinds of people Church members helped. Invite the children to think of people in their neighborhoods or schools who might “[stand] in need” (Alma 1:30) of their love and help. To reinforce this principle, sing together a song about kindness, such as “I’ll Walk with You” (*Children’s Songbook*, 140–41).

ALMA 4:8–20

My testimony can strengthen others.

Alma gave up his position as chief judge so he could spend more time sharing his testimony and helping people repent. His example might inspire the children to share their testimonies more often.

Possible Activities

- Read Alma 4:8–12, 15 with the children, and ask them to identify the problems that were happening in the Church, as described in these verses. Invite the children to suggest some things Alma

could do to solve these problems. Help them find out, in Alma 4:16–20, what Alma decided to do. Why is testimony so powerful?

- To help the children understand what a testimony is and what it includes, show the video “Apostle Testimony Montage” (ChurchofJesusChrist.org); sing together a song about the topic, such as “Testimony” (*Hymns*, no. 137); or use this week’s activity page. Ask the children to share what they learn about testimonies from these resources.



Encourage Learning at Home

Help the children think of someone they can share their testimonies with next week. Encourage them to write a plan to help them accomplish their goal.

Improving Our Teaching

Ask questions that invite testimony. “Asking questions that encourage learners to bear testimony of the principles being taught can be a powerful way to invite the Spirit” (*Teaching in the Savior’s Way*, 32). To invite children to bear testimony, ask questions that prompt them to think about and share how they feel about the Savior or His gospel. You could also ask about experiences they have had with prayer, service, ordinances such as baptism, or feeling the influence of the Holy Ghost.

I can bear testimony of the gospel of Jesus Christ (Alma 4:19).

Color the border around the pictures that are part of a testimony one color and the things that are not part of a testimony another color.

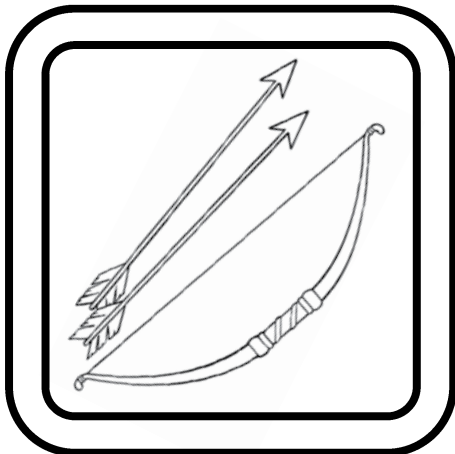
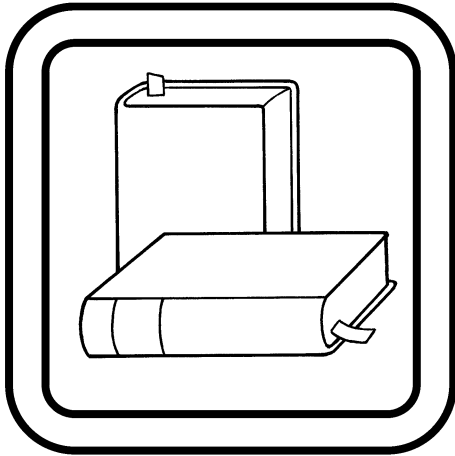



Ye Are Not Forgotten, by Jon McNaughton

JUNE 1-7

Alma 5-7

“HAVE YE EXPERIENCED THIS MIGHTY CHANGE IN YOUR HEARTS?”

Prayerfully consider principles in Alma 5-7 that you feel are especially relevant to the children you teach.

RECORD YOUR IMPRESSIONS _____



Invite Sharing

Invite the children to share what they remember learning about Alma the Younger a few weeks ago. Explain that after Alma was converted, he taught the people important things about the gospel. Let the children share what they know about the things he taught.



Teach the Doctrine: Younger Children

ALMA 5:44-48

I can gain my own testimony through the Holy Ghost.

The children you teach can develop their own strong testimonies, even while they are young.

Possible Activities

- Use a picture of Alma the Younger (see *Gospel Art Book*, no. 77) to review the account of the angel visiting him (see Mosiah 27). Then ask the children to describe what a testimony is, and help them as necessary. Explain that Alma worked to gain a testimony after the angel visited him. Slowly read Alma 5:46 a few times, and invite the children to listen for what Alma did and how he knew the truth. (You may need to explain that fasting means going without food and water.)



When we accept the gospel, it's like starting a new life.

- Display pictures of things that grow gradually and need constant care, like a plant or a baby animal. Ask the children to share how we

take care of these things and help them grow. Remind them that we must also take constant care of our testimonies.

- Use an empty balloon to represent a testimony and blow air into it each time you share something that helps testimonies grow. Tie the balloon and pass it around, asking the children to share one thing they can do to help their testimonies grow. Invite the children to draw themselves doing things that will strengthen their testimonies.

ALMA 7:10-13

The Savior took upon Himself my sins, pains, and afflictions.

The truths in Alma 7:10-13 can help the children know that Jesus Christ cares about them and can help them.

Possible Activities

- Show the children a picture of Jesus. Explain that He knows what it’s like to be hurt, sad, or scared. Read some of the words in Alma 7:11-13 that describe what the Savior suffered, and explain words the children might not understand. Point out that Jesus can help and comfort us when we are sad. Share how the Savior has helped and comforted you.
- Ask the children to share experiences when they were sick or in pain or had another problem that made them sad. Bear your testimony that the Savior has suffered those things too and knows how to help us.

ALMA 7:19-20

The path back to Heavenly Father and Jesus Christ is straight.

How can you use Alma’s description of the path back to Heavenly Father to help the children learn to make good choices?

Possible Activities

- Read Alma 7:19 to the children, and explain that when we make good choices, we are in the path that leads back to Heavenly Father. Give the children a series of choices or actions (such as being unkind to family members or serving them). Ask them to tell you if each choice is good and leads back to God or if it is evil and leads away from Him.
- Read Alma 7:20 and help the children understand the words in these verses that describe the path back to God. Draw on the board a straight path from us to Heavenly Father. Then draw a crooked path that includes dead ends that lead away from God. Invite the children to trace both paths with their fingers. Which path is better? Help them think of good choices that will help them stay on the straight path.



Teach the Doctrine:
Older Children

ALMA 5:12-14, 27-28, 57; 7:14-24

I must be born again and then follow the path that leads back to God.

How can you help the children understand what it means to be born again?

Possible Activities

- Show the children a picture of a baby, and invite them to talk about what a baby is like when he or she is first born. Invite a child to read Alma 5:14. To help the children understand what it means to be “spiritually . . . born of God,” ask them to think about what Alma the Younger was like before he was converted. What was he like afterward? (See Mosiah 27:23-32 and Alma 36:12-24.)

Explain that when we have faith in Jesus Christ and live His gospel, it is like we have started a new life, as a baby does.

- Read together Alma 7:19, and explain that after we are born again, we must follow “the path which leads to the kingdom of God.” Hide papers around the room with the following scripture references written on them: Alma 5:12–13, 27–28, 57; 7:14–16, 23–24. Invite the children to find the papers, look up the scriptures, and share what each scripture teaches we must do to return to God’s presence.

ALMA 5:14, 44–48

I can gain my own testimony through the Holy Ghost.

Alma was visited by an angel, but his testimony was “made known unto [him] by the Holy Spirit” (Alma 5:46).

Possible Activities

- Read with the children Alma 5:44–46. What did Alma do to gain his own testimony of the gospel? Give each child a piece of paper and invite them to make a plan to do one thing this week to strengthen their testimonies.
- Pass around a mirror and let children look at their reflections as you read Alma 5:14. What does it mean to have the Savior’s image in our countenance? Share times when someone said or did something that reminded you of the Savior, and ask the children to do the same.

ALMA 7:10–13

The Savior took upon Himself my sins, pains, and afflictions.

As you study Alma 7, ponder how you can build the children’s faith in Jesus Christ so that they will turn to Him in their trials.

Possible Activities

- Invite the children to read Alma 7:11–13, looking for the things Jesus Christ suffered. They may be willing to share experiences when they felt pain, sickness, or afflictions. According to these verses, why was the Savior willing to suffer all of this? (Explain that “succor” means “to help.”)
- Tell the children about an illness, injury, or other affliction you have had, and ask if they have felt something similar. Read together Alma 7:11–13, and point out what Jesus suffered for us. Help the children think of times when the Savior experienced these things, such as when He was tempted (see Matthew 4:1–11) or when He was suffering in Gethsemane. How does it help us to know that Jesus understands our struggles? Share your testimony of Jesus’s power to comfort, help, and heal us.



Encourage Learning at Home

Invite the children to hang a picture of Jesus in a place where they will see it often to remind them of what they learned about Him today.

Improving Our Teaching

Improve as a Christlike teacher. As a teacher, it is important to ponder ways you can increase your ability to help the children build their faith in Heavenly Father and Jesus Christ. Consider using the personal evaluation questions on page 37 of *Teaching in the Savior’s Way*.

**I can have the Savior's
image in my countenance
(see Alma 5:14).**

Color the mirror and cut it out.
Glue a craft stick or thick piece
of paper to the back to make it
sturdy. Hold the mirror and look
into it. As you do, tell someone
some things you can do that will
help others think of the Savior
when they see you.

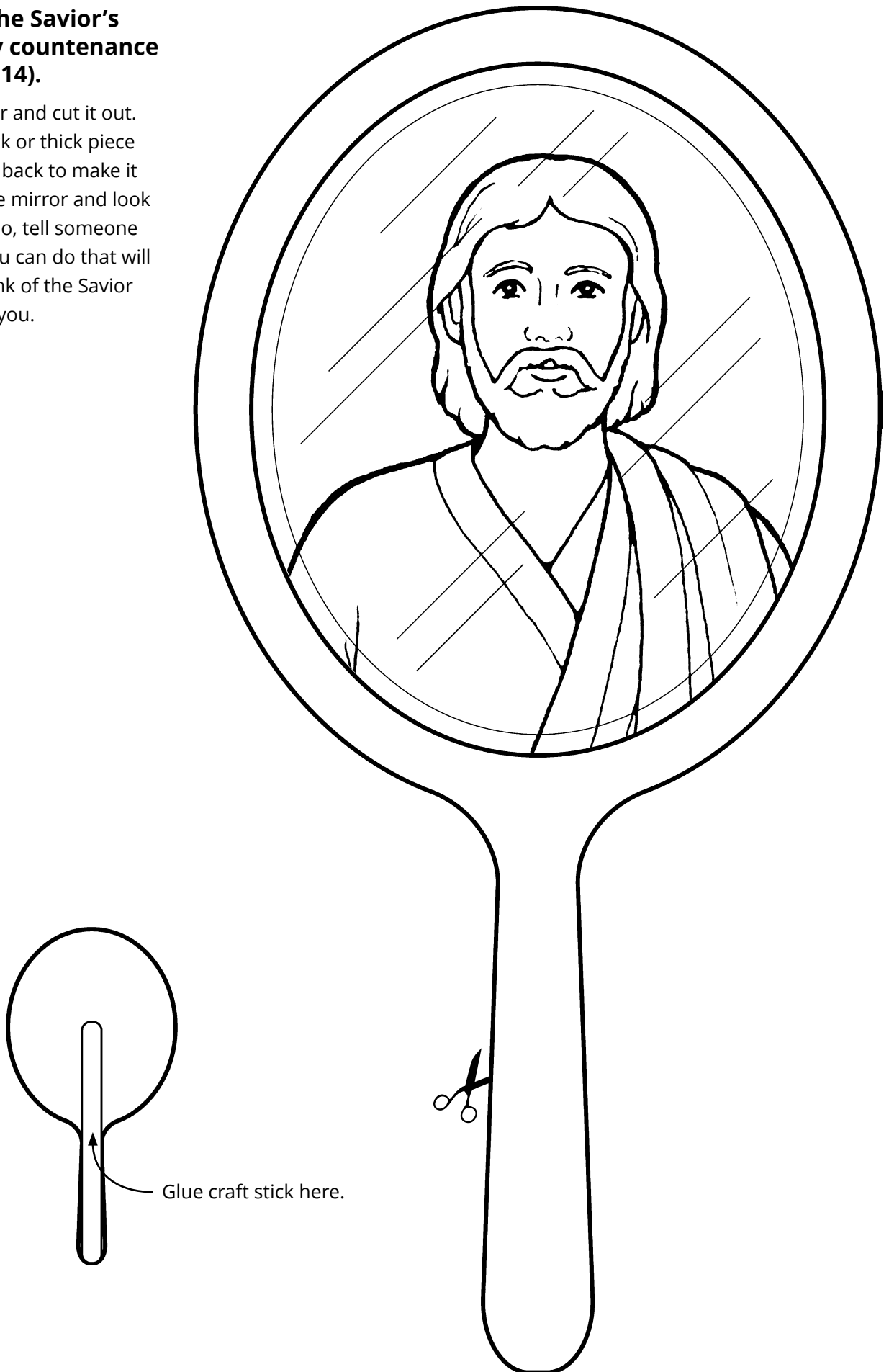



Teaching True Doctrine, by Michael T. Malm

JUNE 8-14

Alma 8-12

“JESUS CHRIST WILL COME TO REDEEM HIS PEOPLE”

As you read what Alma and Amulek taught the people of Ammonihah, what feels especially relevant to the children you teach?

RECORD YOUR IMPRESSIONS _____



Invite Sharing

Invite the children to describe what missionaries do and to tell you about anyone they know who is serving a mission. What do missionaries teach people? Help the children see that Alma and Amulek were missionaries who shared the gospel with the people of Ammonihah.



Teach the Doctrine: Younger Children

ALMA 8

I can share the gospel.

Alma traveled all over the land to preach the gospel, and Amulek preached in his own city to his friends and neighbors. How can you inspire the children

to follow their example and share the gospel with others?

Possible Activities

- Read together the first half of “Chapter 22: Alma’s Mission to Ammonihah” (*Book of Mormon Stories*, 58–63; see also the corresponding video on ChurchofJesusChrist.org). Invite the children to link arms in pairs and pretend to be Amulek and Alma, who taught the gospel together, as they sing a song about missionary work, such as “I Want to Be a Missionary Now” (*Children’s Songbook*, 168).
- Help the children repeat a gospel truth several times, such as “The Book of Mormon testifies of Christ” or “I know Jesus loves me.” Then invite each child to practice sharing this truth with someone else in the class. As part of this activity, you could help the children complete this week’s activity page.
- Ask the children to tell you about something they have shared with a family member or a friend—such as a toy or candy. Help them list some important things we can share with others about

Jesus Christ. Explain that because the gospel is so important, Alma went to share it with the people in many other cities so they could learn how to be happy.

ALMA 8:18-22

I can be a good friend.

Amulek’s service to Alma is a good example to the children of how they can love and serve others.



We can be good friends to others.

Possible Activities

- Invite one child to pretend to be Amulek and another child to pretend to be Alma as you tell the story in Alma 8:18–22. Let the children help tell the story, and invite different children to be Alma and Amulek. How was Amulek a good friend to Alma? Ask the children to talk about how someone has been a friend to them. How did that experience make them feel? Why does God want us to be good friends to others?
- Find or draw a picture representing friendship (like two people hugging or a heart), and cut it into puzzle pieces. On the back of each puzzle piece, write something that Alma and Amulek did to be good friends or things we can do to be a good friend. Invite the children to take turns selecting a piece and adding it to the puzzle as you read what is written on the back of it. Help them think of people they can be a friend to. Testify that Jesus Christ is the greatest friend we can have.

ALMA 11:43-44

After death, I will be resurrected.

Amulek taught the people of Ammonihah about the Resurrection. How can you help the children you teach understand what it means to be resurrected?

Possible Activities

- Use your hand to represent a spirit, and use a glove to represent a body. Take your hand out of the glove to show the children that our spirits and bodies will be separated at death. Then place your hand back in the glove to show that our spirits and bodies will be joined together again at the Resurrection. Let the children take turns putting the glove on and taking it off as you read Alma 11:43 to them. Display the picture Mary and the Resurrected Jesus Christ (*Gospel Art Book*, no. 59), and testify that Jesus Christ made it possible for everyone to be resurrected.
- Invite the children to draw pictures of their friends or family members, including extended family members. As the children share their pictures, point to each friend or family member they drew and explain that he or she will be resurrected. Testify that Jesus made it possible for us to be with our families forever.



Teach the Doctrine:
Older Children

ALMA 8-10

I can share the gospel.

Alma and Amulek shared the gospel, even when it wasn’t easy. How might their courage and faith inspire the children you teach?

Possible Activities

- In your own words, summarize the events in Alma 8–10. Select several principles from these events that could help the children share the gospel, such as perseverance (see Alma 8:8–13), testifying of Christ (see Alma 9:26–27), and having a companion (see Alma 10:7–11). Invite the children to read selected verses and tell what they learn about sharing the gospel. Why is it important to tell others about the gospel?
- Invite the children to share experiences when they shared the gospel with someone, or share your own experience. Invite the children to listen for ways they can prepare to share the gospel as they sing a song about missionary work, such as “We’ll Bring the World His Truth” (*Children’s Songbook*, 172). Why does Heavenly Father want us to share the gospel? Help the children plan ways to share the gospel with their friends, such as giving them a copy of the Book of Mormon or inviting them to a Church activity. Give them time to role-play what they might say or do in these situations.

ALMA 11–12

God’s plan is a plan of redemption.

How will you use Alma 11–12 to “[make] known unto [the children] the plan of redemption”? (Alma 12:30).

Possible Activity

- Write on the board some of the principles related to the plan of redemption that are found in Alma 11–12, such as the Fall of Adam and Eve, the Atonement of Jesus Christ, repentance, death, resurrection, and judgment. Read a few verses from Alma 11 or 12 that teach about the principles, and give the children time to draw a

picture representing each principle. What is the Savior’s role in this plan? Then invite the children to use their pictures to role-play teaching a friend about God’s plan.

ALMA 12:10

If I don’t harden my heart, I can receive more of the word of God.

When it comes to learning spiritual truths, the condition of our hearts is just as important as the abilities of our minds.

Possible Activities

- Read together Alma 12:10, and discuss what it means to “harden” our hearts. Why does a hard heart make it more difficult to learn from God?
- To illustrate this principle, show the children a sponge and a rock and ask them which will absorb water better. How can we show the Lord that we want our hearts to be soft like the sponge?



Encourage Learning at Home

Invite the children to look for opportunities to share the gospel or to help someone else this week.

Improving Our Teaching

Bear testimony to your class. A testimony can be as simple as “I know that Heavenly Father loves each of you” or “I feel good inside as I learn about Jesus Christ.” (See also *Teaching in the Savior’s Way*, 11.)

Sharing the gospel can require persistence and patience (Alma 8-12).

Color the pictures and draw yourself in the space. In the blank space, write your name and a way you can share the gospel. Then cut out the rectangle. Fold the rectangle in half along Fold 1. Then fold the paper again along Fold 2 and then along Fold 3. Cut along the dotted line, and unfold the paper doll chain.

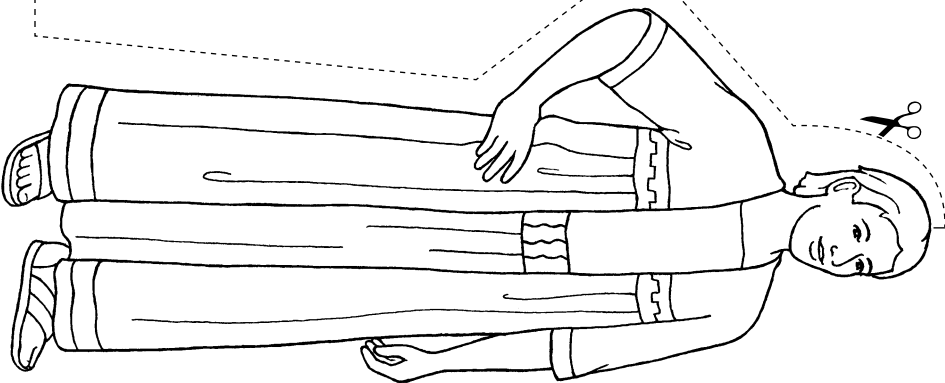
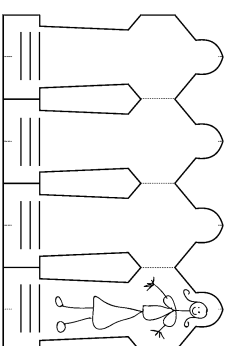

Alma
went back to a wicked city to teach the gospel (see Alma 8:14-18).

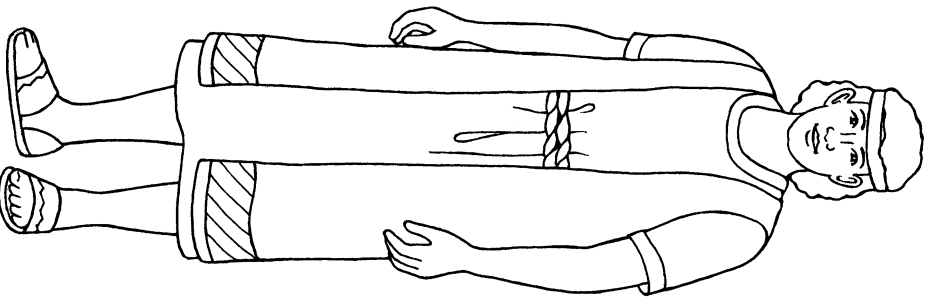

Amulek
shared his testimony (see Alma 10:1-12).

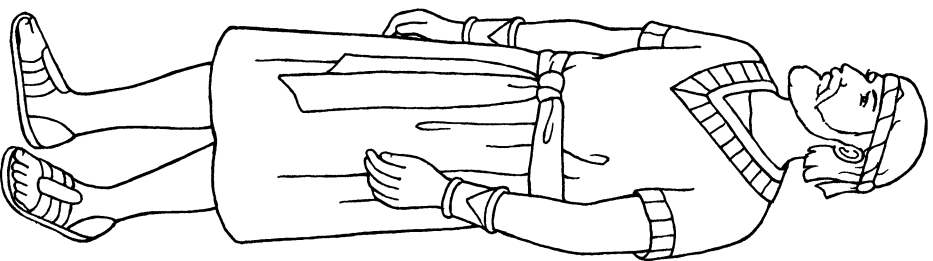

Zezrom
was converted and later became a missionary (see Alma 31:5-6).

Fold 3

Fold 2

Fold 1



Illustration of Alma and Amulek being delivered from prison, by Andrew Bosley

JUNE 15–21

Alma 13–16

“ENTER INTO THE REST OF THE LORD”

You are with the children in your class for only a short time each week. You will bless their lives profoundly if you can inspire them to continue learning from the Book of Mormon outside of class—especially with their families.

RECORD YOUR IMPRESSIONS _____



Invite Sharing

Give the children opportunities to share what they already know about the stories in Alma 13–16. To help them, show pictures such as those in *Come, Follow Me—For Individuals and Families* or “Chapter 22: Alma’s Mission to Ammonihah” (*Book of Mormon Stories*, 58–63).



Teach the Doctrine: Younger Children

ALMA 13:1–2, 6, 16

The priesthood helps me come unto Christ.

Prayerfully ponder what the children in your class need to understand from what Alma taught about the priesthood in these verses.



Priesthood ordinances help us look to Jesus Christ for redemption.

Possible Activities

- Ask the children to repeat with you a simple definition of the priesthood, such as “the priesthood is the power of God.”
- Open the scriptures to Alma 13:2, and tell the children that God calls priesthood holders “that thereby the people might . . . look forward to his Son.” To illustrate how priesthood holders do this, show pictures of ways priesthood holders serve (see *Gospel Art Book*, nos. 38–41, 103–9), and then share stories about ways Jesus served (see Matthew 26:26–28; Mark 5:22–24, 35–43).
- Turn to Alma 13:6, and explain that priesthood holders “teach [God’s] commandments unto

the children of men.” Help the children think of priesthood holders they know of. How do they teach the commandments? Invite the children to draw a picture of a priesthood holder they know teaching someone God’s commandments.

ALMA 14:18–29

Heavenly Father strengthens me according to my faith.

The account of Alma and Amulek being delivered from prison can inspire the children to turn to the Lord when they need help.

Possible Activities

- Display the figures of Alma and Amulek on this week’s activity page as you tell the story in Alma 14:18–29. You could also refer to “Chapter 22: Alma’s Mission to Ammonihah” (*Book of Mormon Stories*, 58–63, or the corresponding video on ChurchofJesusChrist.org). Let the children take turns using the figures to tell the story. Emphasize that Alma and Amulek were given strength to escape the prison “according to [their] faith which is in Christ” (Alma 14:26).
- Help the children imagine how Alma and Amulek might have felt while in prison, and invite them to act out these feelings (see verse 22). Explain that Alma asked the Lord for help (see verse 26). Testify that God will strengthen us when we pray with faith.
- Use this week’s activity page to teach the children about some ways God strengthens those who have faith. While the children are coloring the activity page, tell about a time when God gave you strength.

ALMA 16:1–8

I am blessed when I follow the prophet.

Zoram, the chief captain of the Nephite armies, knew that Alma was a prophet and sought his guidance. Because of this, Zoram was successful.

Possible Activities

- Share in your own words the account in Alma 16:1–8. Emphasize that because Zoram and the Nephite armies followed the prophet Alma, the Nephites were able to rescue their friends who were being held as prisoners by the Lamanites. Share an experience when you were blessed because you followed the prophet.
- Show a picture of the President of the Church, and share a few things he has taught us to do. Help the children think of ways they can follow Jesus by doing what His prophet teaches us.
- Show pictures of prophets (see *Gospel Art Book*, nos. 6–9, 14, 18, 26–27) as you sing with the children a song about prophets, such as “Follow the Prophet” (*Children’s Songbook*, 110–11). Emphasize phrases in the song that teach why we should follow the prophet.



Teach the Doctrine: Older Children

ALMA 13:1–19

The priesthood helps me come unto Christ.

As you read Alma 13:1–19, what do you find that deepens your reverence for the priesthood? What do you feel inspired to share with the children you teach? The following ideas might help.

Possible Activities

- Read with the children Alma 13:10 and 13, searching for traits a priesthood holder should have. Ask them to think of people they know who are good examples of these traits.
- Help the children make a list of ordinances we receive through the priesthood (see “Ordinances” in *True to the Faith*, 109–10). Ask

someone to read Alma 13:16. How do these ordinances help us “look forward to [Jesus Christ] for a remission of [our] sins”?

- Ask the children if they know how the Melchizedek Priesthood got its name. Help them find the answer in Alma 13:14–19 and Doctrine and Covenants 107:1–4. What do we learn from Melchizedek about how the priesthood should be used?

ALMA 14:18–29

Heavenly Father strengthens me according to my faith.

Alma and Amulek were in prison for many days before the Lord freed them. This story can help the children learn that their trials may not have quick or easy solutions, but the Lord will strengthen them “according to [their] faith” (Alma 14:26).

Possible Activities

- Write questions on the board to help the children search for details from Alma 14:18–29, such as *What did the judges do to Alma and Amulek in prison?* or *How did they show their faith in Jesus Christ?* Give each child a verse or two to read, looking for answers to the questions.
- Invite the children to draw pictures of scenes from Alma 14:18–29, and then let them use their pictures to tell the story. How can we be like Alma and Amulek?
- Share an experience in which you showed faith in the Lord and He gave you strength to overcome or endure a trial. Encourage the children to share similar experiences they’ve had.

ALMA 15:3–12

The gospel can change hearts.

Zeezrom actively opposed Alma and Amulek at first, but their testimonies touched his heart and inspired him to repent. As you study these verses, consider how Zeezrom’s experience might inspire the children you teach.

Possible Activities

- Review with the children what they learned last week about Zeezrom. Read together Alma 15:3–12 to discover how he changed.
- Invite the children to imagine they met Zeezrom before he repented. What would they say to help him believe the gospel? They could compare what they would say with what Alma and Amulek taught Zeezrom (see Alma 11:40–46; 15:6–11). Why might knowing these truths help someone want to change?



Encourage Learning at Home

Invite the children to think of something they can do this week to show their faith in the Lord. Encourage them to share their plans and experiences with their families.

Improving Our Teaching

Learn to recognize revelation. “Revelation often comes ‘line upon line’ (2 Nephi 28:30), not all at once. . . . As you ponder how the gospel principles you are teaching will bless your class members, ideas and impressions will come throughout your daily life—as you travel to work, do household chores, or interact with family and friends” (*Teaching in the Savior’s Way*, 12).

Heavenly Father strengthens those who have faith (Alma 14:18-29).

Cut out the rectangle around the outer edge. Punch out the circles, and thread yarn through them to make prison bars. Tape the yarn in place on the back, as shown. Fold the paper and use it to tell the story of Alma and Amulek to someone.

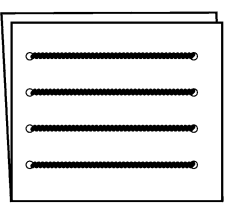
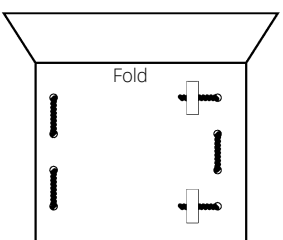

Alma and Amulek were cast into prison.

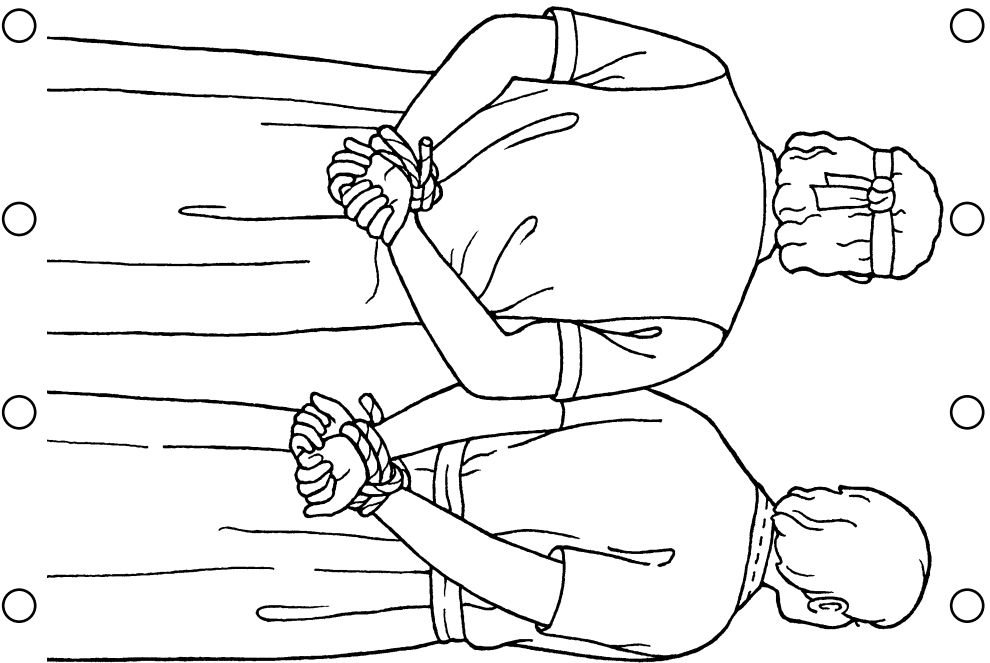

Because of their faith, God gave them power to escape.

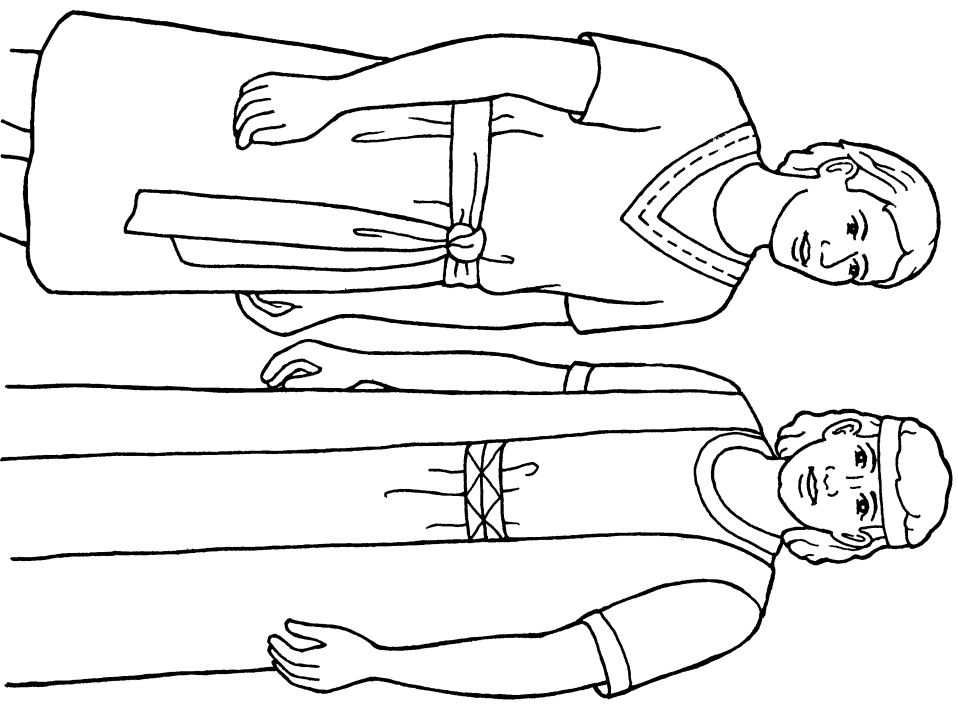



Ammon and King Lamoni, by Scott M. Snow

JUNE 22-28

Alma 17-22

“I WILL MAKE AN INSTRUMENT OF THEE”

Just as Lamoni and others in this account had life-changing spiritual experiences, the children you teach can have spiritual experiences with the scriptures that will influence their lives for years to come. Keep this in mind as you ponder how you will teach them.

RECORD YOUR IMPRESSIONS _____



Invite Sharing

Show a picture depicting an event in Alma 17-22 (see this week’s outline in *Come, Follow Me—For Individuals and Families*). Ask the children to tell you about what they see in the picture.



Teach the Doctrine: Younger Children

ALMA 17-19

I can share the gospel with others.

How can the example of the sons of Mosiah inspire your class to share their testimonies with others?

Possible Activities

- Help the children act out Ammon’s story in Alma 17-19. You could refer to “Chapter 23: Ammon: A Great Servant” (*Book of Mormon Stories*, 64-68, or the corresponding video on ChurchofJesusChrist.org). If you think the children would enjoy it, bring simple costumes and props. Tell the children what you learn from the story, and invite them to do the same.
- Display an instrument or tool, and talk to the children about what it is used for. What other tools do the children know of? Invite them to pretend to use a tool. Explain that just as we use instruments or tools to get things done, Heavenly Father can use us to do His work. Read Alma 17:11, and explain that Ammon and his brothers were Heavenly Father’s instruments to help the Lamanites learn the gospel.
- Invite the children to run in place and pretend to knock on doors as you tell the story of Abish going from house to house telling people about

God’s power (see Alma 19:16–34). Help the children think of ways they can be like Abish and share the gospel with others.

- Invite the children to draw a picture of themselves sharing the gospel with someone. Help them think of specific things they can share. Sing together a song about sharing the gospel, such as “I Want to Be a Missionary Now” (*Children’s Songbook*, 168). Give them an opportunity to share their feelings about the things Ammon taught.

ALMA 17:21-25; 20:9-27; 22:1-3

I can help others come unto Christ by showing my love for them.

Ammon’s love and service softened the hearts of King Lamoni and his father. What can the children learn from these accounts?

Possible Activities

- Summarize Alma 17:21–25 for the children, emphasizing that Ammon wanted to serve Lamoni. Invite the children to share experiences when they served someone. Remind the children that Ammon’s great service helped King Lamoni want to learn about the gospel (see Alma 18:15–23). Invite the children to think of someone they can serve today, and discuss how they can serve that person.
- Tell the children the account in Alma 20:8–27. You can use “Chapter 24: Ammon Meets King Lamoni’s Father” (*Book of Mormon Stories*, 69–70, or the corresponding video on ChurchofJesusChrist.org). Ask the children to think of different actions they can do each time you mention Ammon, Lamoni, or Lamoni’s father. Point out that one reason the heart of Lamoni’s father changed was because Ammon loved Lamoni so much. Invite the children to draw a picture of something they can do to show love for someone.



Teach the Doctrine:
Older Children

ALMA 17:1-4

My testimony grows when I read the scriptures, pray, and fast.

Mosiah’s sons grew strong in the gospel and became mighty missionaries because they diligently studied the scriptures, prayed, and fasted. These same things can also help the children you teach.

Possible Activities

- Bring to class items that represent scriptures, prayer, and fasting, such as a set of scriptures, a picture of someone praying, and a picture of food, and explain what each item represents. Read Alma 17:1–4, and ask the children how these things helped the sons of Mosiah. How does reading the scriptures, praying, and fasting help us come closer to Heavenly Father?
- Use the topics index of the *Children’s Songbook* to help the children find songs about scripture study and prayer. Sing some of these songs together, and help the children identify what the songs teach about how doing these things blesses us.

ALMA 17-18; 22:1-3

I can help others come unto Christ by showing my love for them.

Ammon’s desire to be Lamoni’s servant eventually led to the opportunity to teach Lamoni when his heart was open and ready to receive the gospel.

Possible Activities

- Help the children read verses from Alma 17:21–39 that tell the account of Ammon’s service to King Lamoni. Invite them to draw pictures of

people or events in the story and then to tell the story in their own words. Help the children see how Ammon’s service influenced the king (see Alma 18:9–23). What can we learn from this account about how to help others want to learn more about the gospel?



Minerva K. Teichert (1888–1976), *Ammon Saves the King's Flocks*, 1935–1945, oil on masonite, 35 x 48 inches. Brigham Young University Museum of Art.

- Read Alma 22:1–3, and ask the children to listen for how Ammon’s good example affected King Lamoni’s father. Invite them to think of someone they know who needs to know about the gospel. Suggest to the children that their love and good example might help this person see how great the gospel is. Help the children think of ways they can be good examples and show love to the people they thought of.
- Invite full-time missionaries or a recently returned missionary to share the story of Ammon in Alma 17–18. Ask them to share what they learned about missionary work from Ammon and the role service played in their efforts. Discuss with the children ways they can follow Ammon’s example.
- As a class, write a list on the board of things the children can do to serve their family members. How will doing these acts of service bless the entire family?

ALMA 18:24–43; 19:16–34

I can share the gospel with others.

How can you use the accounts in these verses to inspire the children to be missionaries like Ammon and Abish were?

Possible Activities

- Show pictures representing some of the truths Ammon shared with King Lamoni, found in Alma 18:24–40 (see this week’s activity page). Invite the children to pretend to be missionaries and share what they know about these truths with one another.
- Read the account of Abish with the children (see Alma 19:16–20, 28–29). Invite the children to take turns pretending to be like Abish by knocking on the classroom door and testifying of what happened in Alma 19:1–17. How can we be like Abish and testify of the truths we know?



Encourage Learning at Home

Invite the children to prayerfully make a goal with their family to share the gospel with someone.

Improving Our Teaching

Follow up on invitations to act. When you invite the children to act on what they are learning, follow up on that invitation during the next class. This shows the children that you care about how the gospel is blessing their lives. As they share their experiences, they will be strengthened and will help one another live the gospel (see *Teaching in the Savior’s Way*, 35).

I can share the gospel with others (Alma 18:24-49).

Cut out the ten cards to make a matching game. Mix up the cards and lay them face down. Turn over two cards. If they match, share what you could teach a friend about the truth in the picture (ask for help if needed). If they don't match, turn the cards back over and try again.

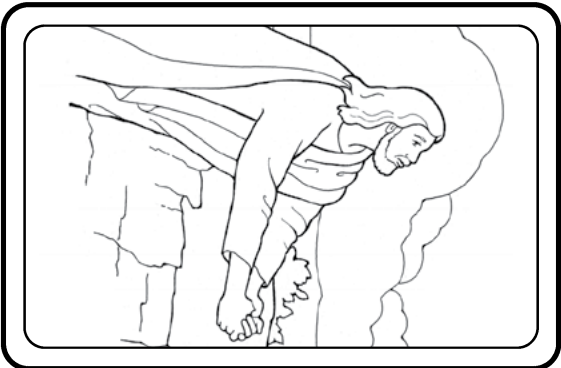
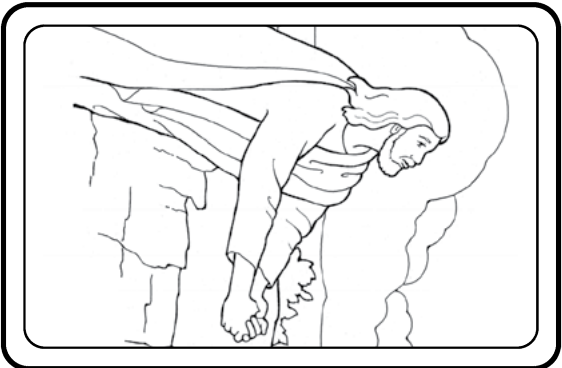
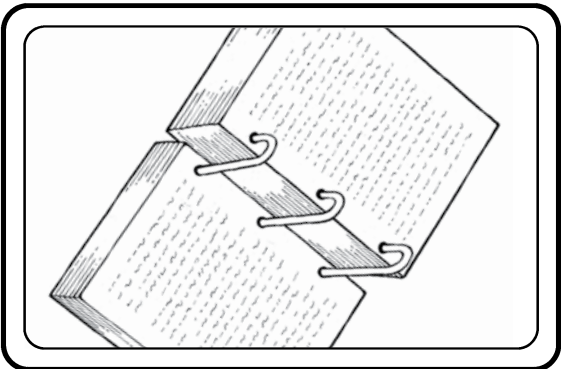
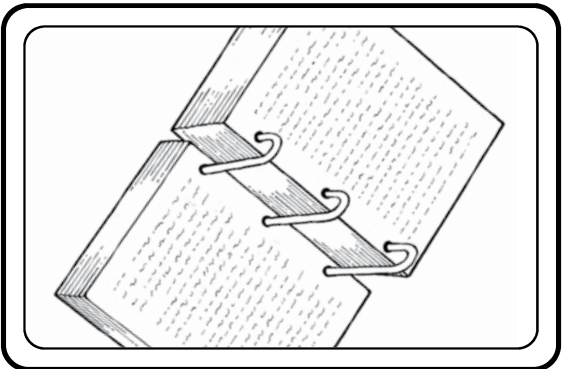
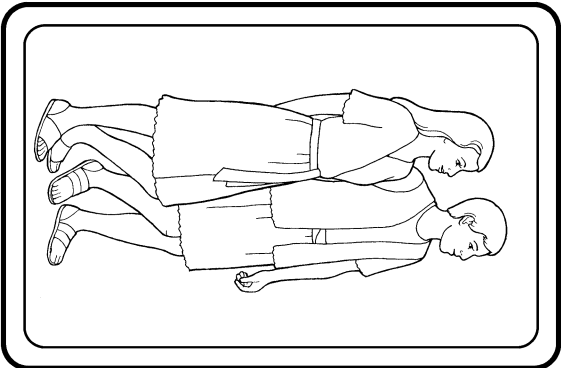
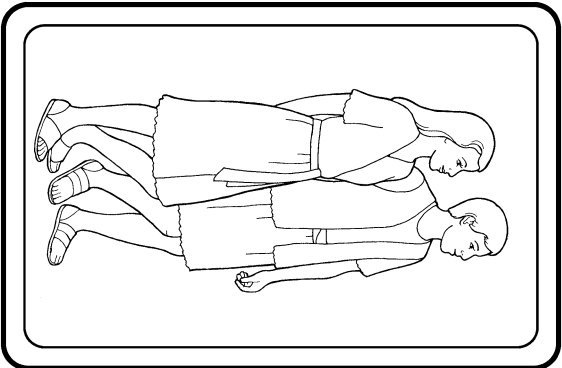
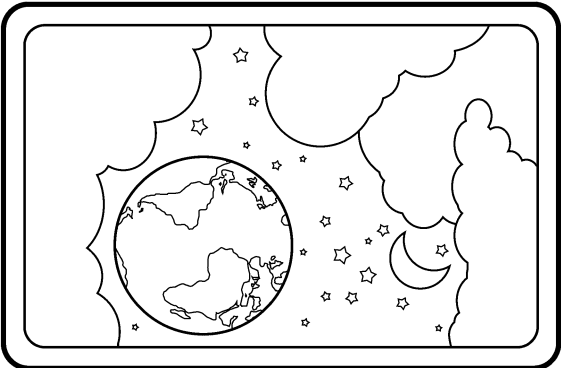
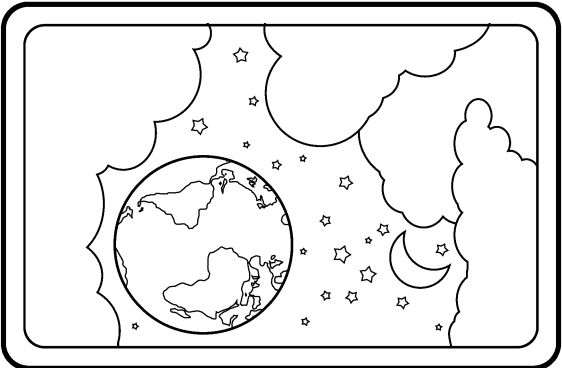
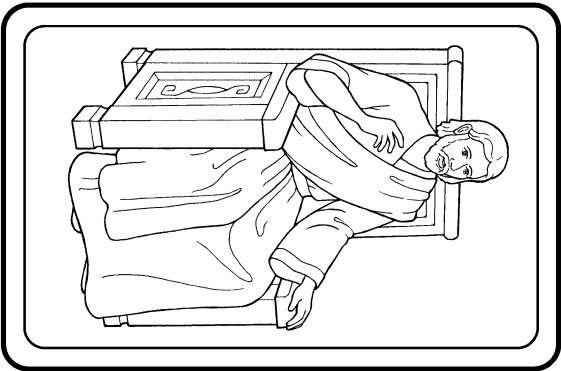
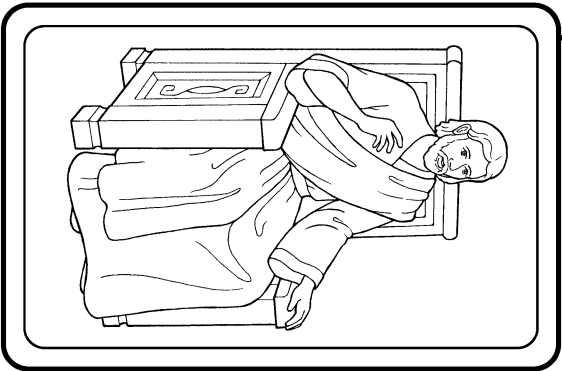



Anti-Nephi-Lehies Bury Their Weapons of War, by Jody Livingston

JUNE 29–JULY 5

Alma 23–29

THEY “NEVER DID FALL AWAY”

Prayerfully study Alma 23–29, seeking inspiration about what the children need and how to help them.

RECORD YOUR IMPRESSIONS _____



Invite Sharing

Draw a happy face on a piece of paper, and allow individual children to hold it. As they hold the paper, invite them to name something they are learning from the Book of Mormon that brings them joy.



Teach the Doctrine: Younger Children

ALMA 24:6–24

I am blessed when I keep my promises.

What did you learn in your study of Alma 24:6–24 that can help the children understand the importance of keeping a righteous promise?

Possible Activities

- Read some verses or phrases from Alma 24:6–24 to teach the children about the Anti-Nephi-Lehies, the promise they made, and how they kept the promise. You could also use the picture in this week’s outline in *Come, Follow Me—For Individuals and Families* or “Chapter 26: The People of Ammon” (*Book of Mormon Stories*, 73–74, or the corresponding video on ChurchofJesusChrist.org).
- Describe how the Anti-Nephi-Lehies kept their promise by burying their weapons. Invite the children to draw a sword and then pretend to dig a hole and bury their sword. Help the children think of promises they make. Why is it important to keep promises? Explain that when we are baptized, we make promises with God and He makes promises with us. These are called covenants. Testify that we are blessed when we keep our promises with God.

ALMA 26; 29

The gospel brings me joy, and I can share this joy with others.

Ammon, who helped to teach the gospel to the Anti-Nephi-Lehies, received great joy from preaching the gospel. Alma, who also taught the gospel to many people, received this same joy. We can experience similar joy when we share our testimonies with others.

Possible Activities

- Select a few phrases from Alma 26 or 29 that speak of joy, and read them to the children (see, for example, Alma 26:11, 13 or Alma 29:13–14). Invite the children to stand every time they hear the words “joy” or “rejoice.” Help the children understand that sharing the gospel made Alma and Ammon happy. Share an experience when sharing the gospel brought you joy.
- Invite the children to draw pictures of things that bring them joy. Invite each child to give his or her drawing to another classmate and explain it. Point out that when something brings us joy—such as the gospel—our joy grows when we share it.
- Give a child a copy of the Book of Mormon, and let him or her practice sharing it with another class member. Encourage the children to explain how they feel about the Book of Mormon. Why do we share the Book of Mormon with others?

ALMA 27:20–30

I can help my friends live the gospel.

The Nephites protected the Anti-Nephi-Lehies from their enemies and helped them keep the covenants they had made with the Lord.

Possible Activities

- Tell the children the story of the Anti-Nephi-Lehies making a promise not to fight anymore (see Alma 27:20–30). Explain that because of

the Anti-Nephi-Lehies’ promise, they could not defend themselves from their enemies. Read Alma 27:23, and explain that their friends among the Nephites chose to protect the Anti-Nephi-Lehies so they could keep their promise. How can we help our friends keep their promises? Tell about a time when a friend helped you keep your promises with God.

- Role-play with the children situations in which they can, in a kind way, help others choose the right. For example, what can we say to a friend who wants to lie or be mean?



**Teach the Doctrine:
Older Children**

ALMA 24

Covenants are promises I make with God and He makes with me.

The Anti-Nephi-Lehies buried their weapons and promised never to kill again. Similarly, the children you teach can keep their covenants.

Possible Activities

- Give all the children small rocks, and invite them to write the word *covenant* on their rock. Explain that a covenant is a promise between Heavenly Father and His children. How do our covenants make us strong or “firm” like a rock? (Alma 24:19). Read together Alma 24:16–25 to learn what covenant the people of Ammon made and how they honored their covenant. Invite the children to take the rocks home as a reminder to keep their covenants.
- Read with the children Alma 24:16–19, and discuss what the Anti-Nephi-Lehies did to show God they had repented. What did they covenant not

to do? Explain that the covenants we make are “a testimony to God” that we want to follow God’s commandments (verse 18). What covenants have the children made?

- Invite the children to draw pictures of the Anti-Nephi-Lehies’ weapons. Then invite them to write, on the back of the weapons, something they feel they should change in order to follow Jesus Christ more fully. Let them pretend to bury their weapons and make a plan to act on what they wrote.

ALMA 24:7–10; 26:23–34; 27:27–30

Because Heavenly Father is merciful, we can repent and change.

Recently the children have been learning about Alma, Ammon, and the Anti-Nephi-Lehies. How can you use these accounts to illustrate that Heavenly Father is merciful to those who sincerely repent?

Possible Activities

- Write *Before* and *After* on the board. Ask some of the children to read the following verses to find out what the Lamanites were like before Ammon and his brothers taught them: Alma 17:14–15; 26:23–24. Ask other children to read the following verses to find out how the Lamanites changed: Alma 26:31–34; 27:27–30. Invite the children to list under the headings what they found. Then invite them to discover, in Alma 24:7–10, how these Lamanites were able to change so completely. Bear your testimony of God’s power to forgive us and help us repent and change.
- Invite the children to read together Alma 26:21–22, looking for the blessings that come to those who repent. Invite the children to describe some of these blessings in their own words.

ALMA 26; 29

The gospel brings me joy, and I can share this joy with others.

These chapters are full of examples of the joy that comes from living and sharing the gospel. How can you use Alma 26 and 29 to inspire the children to seek this joy?

Possible Activities

- Help the children find the words “joy” and “re-joyce” in Alma 26 and 29. Read together some of the verses they find, and discuss what these verses teach about joy. What brought Ammon and Alma joy? Share an experience when you felt joy from living or sharing the gospel, or invite the children to share their own experiences.
- Invite two children to face each other and see who can make the other child smile first. What are some ways we can spread joy to others? How does sharing the gospel spread joy? Help the children think of ways they can share the joy of the gospel with their friends and families.



Encourage Learning at Home

Invite the children to keep their promises as the Anti-Nephi-Lehies did.

Improving Our Teaching

Learn a scripture. Select a scripture phrase or short passage that you think could help the children in your class, and help them memorize it. Visual aids and hand gestures can also help.

I am blessed when I keep my promises (Alma 24:6-24).

The people of Ammon promised not to fight anymore, and they buried their weapons. Write on each line something you could change so you can follow Jesus Christ more fully. For example, you could try to not say mean things to others.

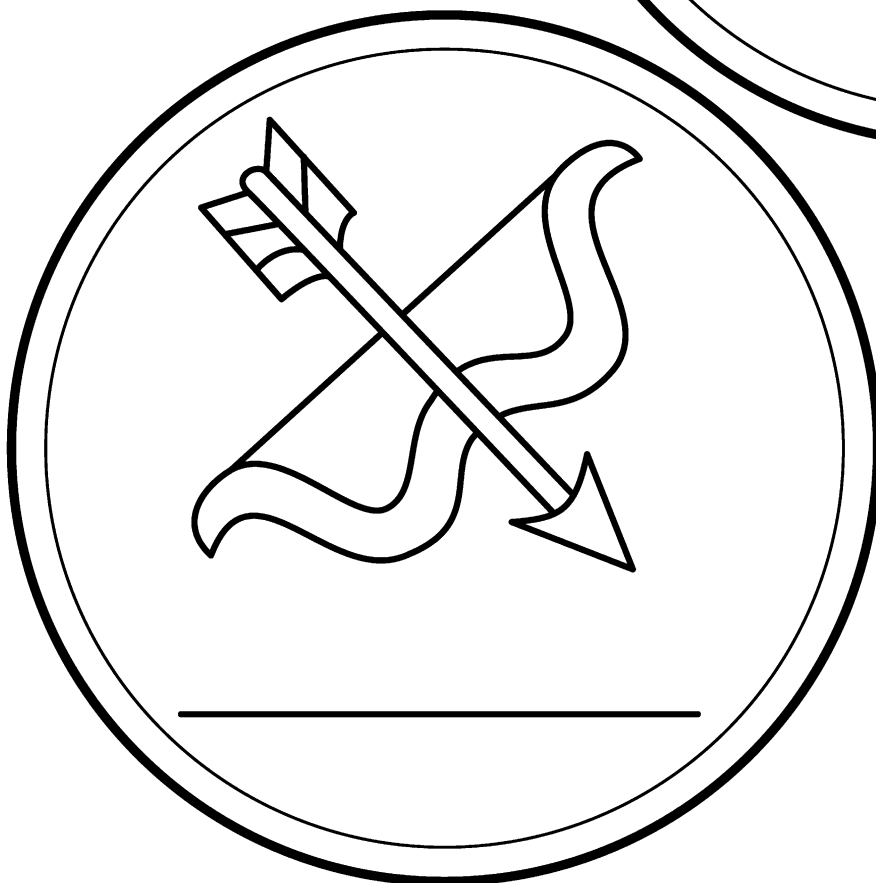
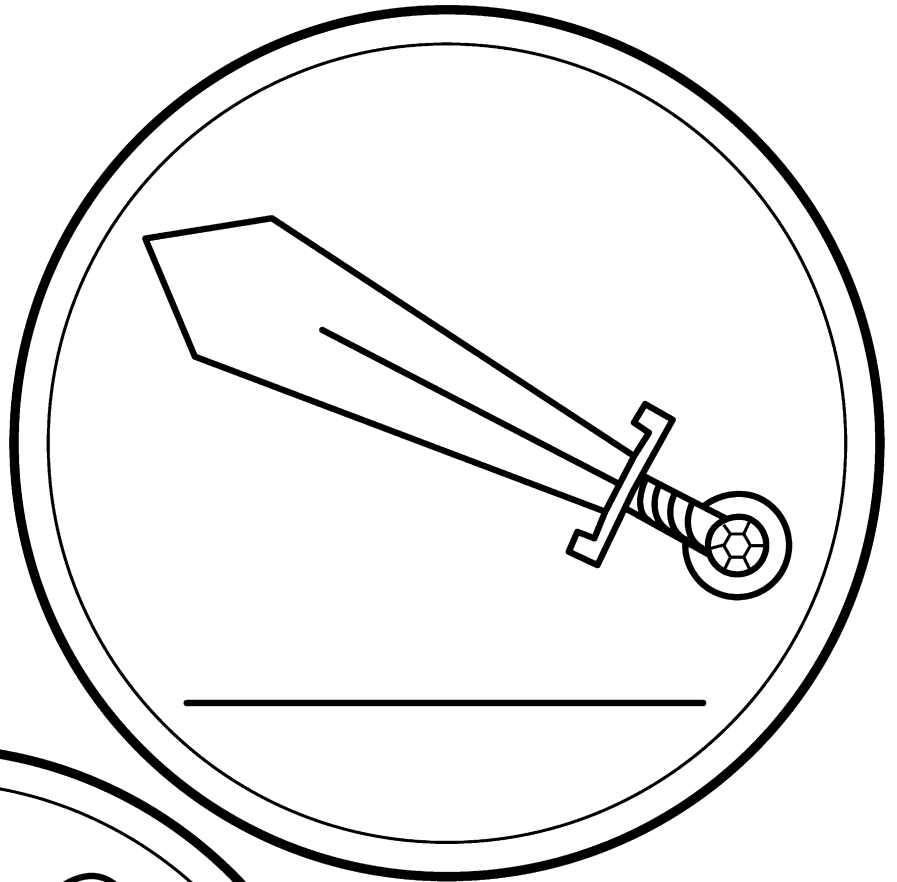



All Things Denote There Is a God (Alma and Korihor) by Walter Rane

JULY 6-12

Alma 30-31

“THE VIRTUE OF THE WORD OF GOD”

Study Alma 30–31 with the children you teach in mind. As you ponder their strengths and needs, the Holy Ghost will help you know how to teach them.

RECORD YOUR IMPRESSIONS _____



Invite Sharing

Invite the children to share answers to questions like the following: When should we pray? What do we say when we pray? Can someone share about how the Zoramites prayed or how Alma prayed?



Teach the Doctrine: Younger Children

ALMA 30:44

All things testify of God.

Alma pointed to things in the sky and on the earth to testify that God lives and directs the universe. What things can you help the children see around them that testify of God?

Possible Activities

- Read Alma 30:44 to the children, and ask them to listen for things that Alma said help us know God is real. Display pictures of some of these things, and ask the children to point to the pictures when you read about them in the verse. Invite the children to draw pictures of things that help them believe in God.
- If possible, take a walk outside with the children or ask them to stand at a window as you read Alma 30:44. Ask them to point out things they see that help them know God is real. This week’s activity page can also help.
- Ask the children to sit in a circle and sing together a song about God’s creations, such as “My Heavenly Father Loves Me” (*Children’s Songbook*, 228–29). While the children sing, invite them to pass around an object such as a ball. When the music stops, ask the child holding the object to share one thing Heavenly Father created that he or she is grateful for.

ALMA 31:5

The word of God is powerful.

When children think of power, they may think of things like superheroes, queens, or kings. You can help them understand that the word of God is more powerful than “anything else” (Alma 31:5).

Possible Activities

- Draw a sword on the board. Read Alma 31:5 to the children, and invite them to listen for what Alma says is more powerful than a sword. Share an experience when the word of God had a powerful influence on you.
- Sing together a song about the scriptures, such as “Scripture Power” (music.ChurchofJesusChrist.org), and ask the children to listen for how the scriptures help us. Repeat the phrase “The word of God is more powerful than . . .” several times, and ask the children to help you complete the phrase.

ALMA 31:8–35

Heavenly Father hears my prayers.

Alma felt sad when he saw how the Zoramites prayed (see Alma 31:24)—they didn’t believe in Jesus Christ and they always said the same prayers in a place where everyone could see them (Alma 31:27). But Alma’s prayer was humble and showed faith in Christ.

Possible Activities

- Briefly summarize the story of Alma and the Zoramites for the children using verses from Alma 31:8–35. You could also use “Chapter 28: The Zoramites and the Rameumptom” (*Book of Mormon Stories*, 78–80, or the corresponding video on ChurchofJesusChrist.org). Point out differences between the Zoramites’ prayer and

Alma’s prayer. Invite the children to imagine they met one of the Zoramite children. What would they say to teach him or her how to pray?

- Help the children identify things the Zoramites said in their prayer (see Alma 31:15–18) as they help you build a Rameumptom tower with blocks or rocks. Explain that this is not how we should pray. Ask the children how we should pray, and let them remove a block or rock for each thing they mention.



**Teach the Doctrine:
Older Children**

ALMA 30

The Book of Mormon warns me against false teachings.

Korihor’s false teachings are described in the Book of Mormon to help us recognize and reject similar teachings in our day.

Possible Activities

- Display some items (such as money or food) and toy imitations of these items. Which would the children rather have? Help the children search Alma 30:12–18 for lies or false teachings that Korihor taught about God.
- Help the children identify the lies Korihor taught and write them on strips of paper to put on the board (see Alma 30:12–18, 24). Ask the children to search Alma 30:32–35, looking for ways Alma responded to Korihor’s lies. Ask the children how they can know that the things Alma taught are true.

ALMA 31:5**The word of God is more powerful than anything else.**

When have you felt the power of the word of God? Consider how your experiences might inspire the children you teach.

Possible Activities

- Invite the children to think of something or someone powerful, or show pictures of a few powerful things. What makes these things powerful? Read Alma 31:5 together, and ask the children what they think this verse means. How is God’s word more powerful than a sword? What does it have the power to do?
- Contact several children in advance, and ask them to think of an experience to share in class when the scriptures or a talk from a Church leader helped them do something good. Why did the word of God make them want to do good things?
- Sing a song with the children about the word of God, such as “Search, Ponder, and Pray” or “Follow the Prophet” (*Children’s Songbook*, 109, 110–11). They could also sing “Scripture Power” (music.ChurchofJesusChrist.org).

ALMA 31:8–35**I can be humble.**

Of all of the mistakes that the Zoramites made, it was their pride that seemed to make Alma especially sad. This could be an opportunity to teach the children the importance of humility.

Possible Activities

- Help the children understand the difference between *pride* and *humility* (see “Pride” and “Humble,

Humility” in the Guide to the Scriptures). Ask the children to take turns reading Alma 31:24–28. Or read together “Chapter 28: The Zoramites and the Rameumptom” (*Book of Mormon Stories*, 78–90). As they read, ask them to notice how the Zoramites showed that they were prideful. How did Alma show he was humble? (see Alma 31:30–33).

- Divide the children into groups, and ask each group to decide on an answer to questions like these: What did the Zoramites set their hearts on? (see Alma 31:24, 28). What are some worldly things that people set their hearts on today? Why might people think they are better than others? When each group shares an answer, let them draw part of a Rameumptom tower on the board. Then ask them to erase parts of the tower each time they think of a way they can show humility.

**Encourage Learning at Home**

Invite the children to teach their families something they learned about the power of the word of God today.

Improving Our Teaching**Help children learn from the scriptures.**

Young children may not be able to read much, but you can still engage them in learning from the scriptures. For example, you could read a passage and invite them to stand up or raise their hand when they hear a specific word or phrase. Then help them understand the word or phrase. (See *Teaching in the Savior’s Way*, 20–21.)

All things testify of God (Alma 30:44).

Color the pictures of things that help us know God is real.
Draw something in the circle that helps you believe in God.

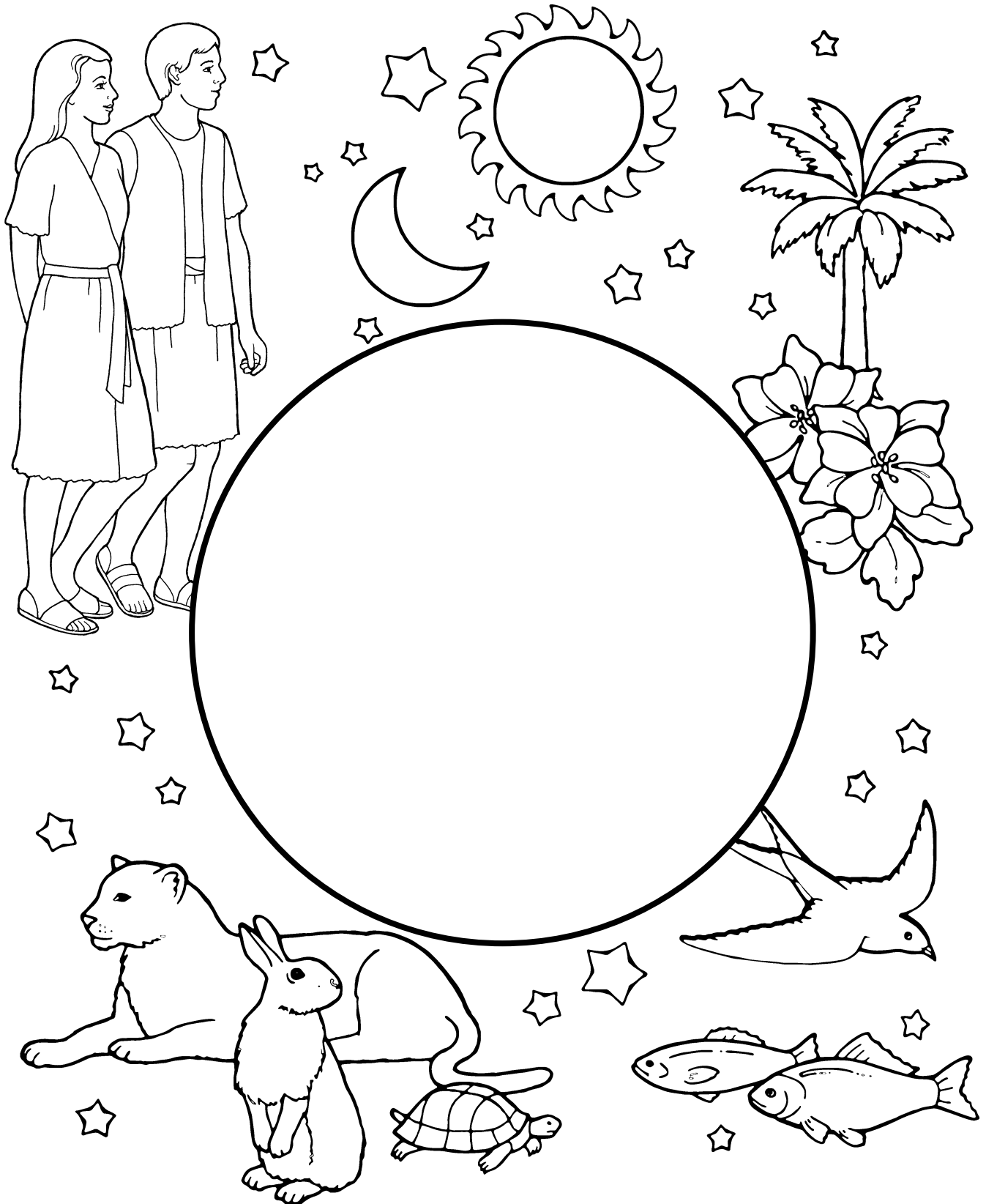



JULY 13-19

Alma 32-35

“PLANT THIS WORD IN YOUR HEARTS”

Keep the children you teach in mind while you prayerfully study Alma 32–35. As you do, thoughts and impressions will come about how to teach them. Record and act on these impressions.

RECORD YOUR IMPRESSIONS _____



Invite Sharing

Place each child’s name in a container. Ask someone to pick one of the names, and invite that child to share something he or she has learned from the Book of Mormon recently. Continue until everyone has had an opportunity, but don’t pressure anyone to share.



Teach the Doctrine: Younger Children

ALMA 32:28-43

I can help my faith in Jesus Christ grow.

Seeds, trees, and fruit are familiar objects that can help children understand abstract principles like faith and testimony. Ponder how you can use Alma’s analogy to teach the children.

Possible Activities

- Summarize Alma 32:28–43; you might use “Chapter 29: Alma Teaches about Faith and the Word of God” (*Book of Mormon Stories*, 81, or the corresponding video on ChurchofJesusChrist.org). Show pictures of a plant in various stages of growth, and ask the children to help you put the pictures in the

correct order (see the pictures in this week’s activity page). Explain that as we live the gospel, our testimony grows—it starts small like a seed but can become big like a tree.

- Show the children a seed, and read to them the first few lines of Alma 32:28. Tell the children that the word of God is like a seed. Ask how we help a seed grow. Let the children pretend to plant a seed, water it, and help it grow. Point out that we can’t see the seed after we plant it, but we know it’s there and growing; we also can’t see Heavenly Father and Jesus Christ, but we know They are real and They love us. Help the children think of things they can do to help their faith in Jesus Christ grow.
- Draw a tree on the board, and let the children add a leaf or a fruit every time they think of something they can do to help their faith in Jesus Christ grow. Invite them to do simple actions to represent the things they thought of.

ALMA 33:2–11; 34:17–27

Heavenly Father hears me when I pray.

The Zoramites prayed only once a week, using the same words every time (see Alma 31:22–23). Alma and Amulek taught that we can pray anytime about any of our spiritual or physical needs.

Possible Activities

- Read phrases you have selected from Alma 33:4–11 that describe places we can pray, and help the children think of places they can pray. Then invite them to draw pictures of themselves praying in those places. Testify that they can pray anywhere, even if they are praying silently.
- Select phrases from Alma 34:17–27 that describe things we can pray about, and read them to the children. Help them think of things they can say to Heavenly Father when they pray, and invite them to draw pictures of these things. Testify that

they can talk to Heavenly Father about anything they are thinking or feeling. Share an experience in which Heavenly Father heard your prayers.

- Sing a song that teaches the children about prayer, such as “A Child’s Prayer” or “We Bow Our Heads” (*Children’s Songbook*, 12–13, 25). Help them notice what the song teaches about prayer.



Teach the Doctrine: Older Children

ALMA 32:1–13, 27–28

If I am humble, the Lord can teach me.

Alma and Amulek had success teaching the Zoramites who were humble and ready to hear the word of God. Consider how you can encourage the children to choose to be humble.

Possible Activities

- Ask the children what they remember learning last week about the Zoramites (see Alma 31:8–24). Remind them that one reason Alma was worried about them was their pride (see Alma 31:24–28). Read together Alma 32:1–5, and ask the children to summarize what had happened to the Zoramites who were poor. Then invite the children to read verses 12–13 to find out why Alma felt that being cast out of their synagogues (or churches) was a good thing for these Zoramites. What are some of the blessings that come from being humble?
- Help the children find a definition of *humble* or *humility* in the Guide to the Scriptures or a dictionary. What other clues about the meaning of these words can they find in Alma 32:13–16? Invite them to think of various ways to complete a sentence like “I am being humble when I _____.”

ALMA 32:26–43**My testimony of Jesus Christ grows as I nourish it.**

Help the children you teach discover what they can do to “plant” the word of God in their hearts.

Possible Activities

- Display a hard, solid object (like a stone) to represent a hard or prideful heart and something soft (like soil) to represent a soft or humble heart. Let the children feel both objects. Then show the children a seed to represent the word of God. Invite them to try to push the seed into the hard object and the soft object. Read together Alma 32:27–28, and talk about what it might mean to “give place” (verse 27) for the word of God in our hearts.
- As you read Alma 32:26–43 together, stop occasionally and invite the children to draw a picture of the seed or plant being described—for example, a seed and a seedling (verse 28), a growing plant (verse 30), and a mature plant bearing fruit (verse 37). Encourage them to label their pictures with references from Alma 32. How is nourishing a seed like nourishing our testimonies of Jesus Christ? How do we nourish our testimonies? Invite the children to silently think about how their testimonies are growing and what they will do to nourish them.

ALMA 33:2–11; 34:17–29**Heavenly Father hears me when I pray.**

The Zoramites had misconceptions about prayer, some of which we still see today. Alma and

Amulek taught powerful truths to overcome these misconceptions.

Possible Activities

- Help the children search Alma 33:2–11 for important words and phrases related to prayer that are repeated. What do these words and phrases teach us about prayer?
- Help the children make a list of situations in which they can pray, including those mentioned in Alma 33:4–10 and 34:17–27 as well as situations in their lives. Invite the children to think about or share experiences when they prayed and felt that God answered their prayers.

**Encourage Learning at Home**

If possible, give each of the children seeds to take home and plant to remind them to help their testimonies of Jesus Christ to grow. Encourage them to tell their families what they learned about exercising their faith in Jesus Christ.

Improving Our Teaching

Testify of promised blessings. When you invite the children to live a gospel principle, tell them about God’s promises to those who live that principle (see *Teaching in the Savior’s Way*, 35).

My faith grows as I nourish it (Alma 32:28-43).

Cut out the picture strip and square. Cut two slits along the dotted lines in the heart. Insert the picture strip and move it upward to see what you can do to plant and nourish the word of God in your heart.

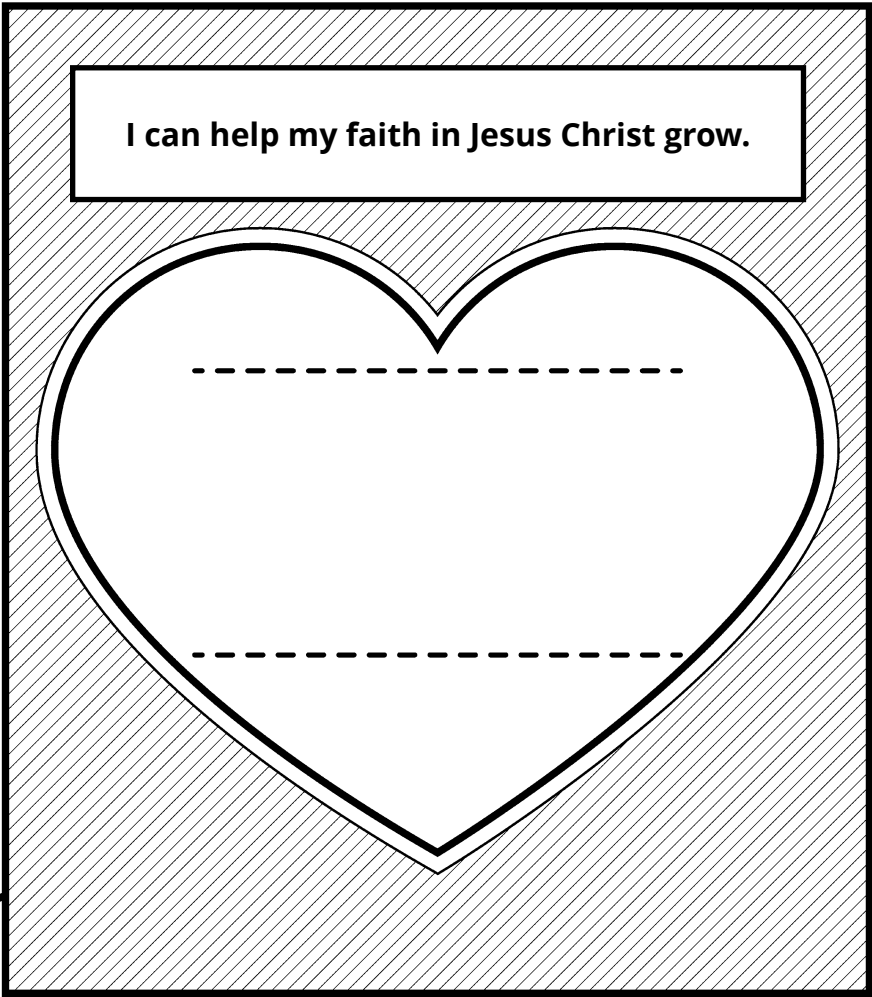
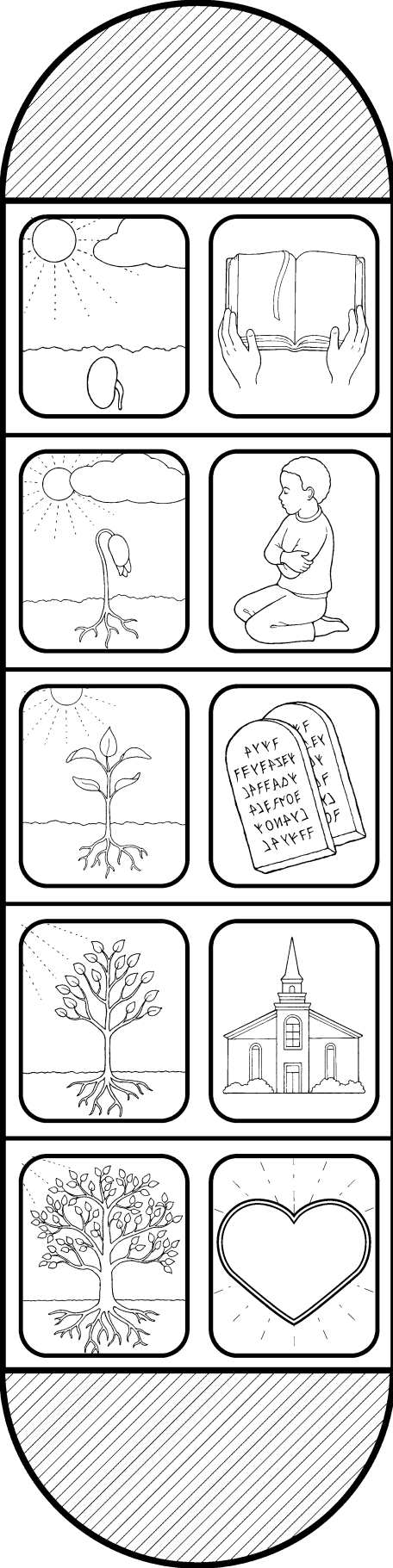
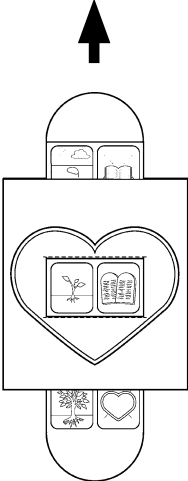



Illustration of a man praying by Joshua Dennis

JULY 20-26

Alma 36-38

“LOOK TO GOD AND LIVE”

As you prayerfully study Alma 36-38, impressions may come to you about the children you teach. Record these impressions; they might spark ideas for learning activities.

RECORD YOUR IMPRESSIONS _____



Invite Sharing

Invite all the children to share something that their parents have taught them. Ask them if they know what Alma taught his sons.



Teach the Doctrine: Younger Children

ALMA 36:6, 20, 24

Repentance brings me joy.

Teaching children about the joy of repentance when they are young can inspire them to repent as they get older.

Possible Activities

- Read Alma 36:20 to the children, and ask them to listen for how Alma felt. Invite them to name some things that bring them joy. Show a picture of the Savior, and explain that Alma felt joy because Jesus Christ forgave his sins.
- Give each of the children a piece of paper with a happy face on one side and a sad face on the other. Ask them to listen while you read Alma 36:6 and to choose which face they should hold up. Explain that Alma repented and felt joy because Jesus Christ forgave him for making bad choices. Ask the children to listen while you read Alma 36:24 about the good choices he made later and to hold up the correct face.
- Sing together a song about Jesus Christ, such as “He Sent His Son” (*Children’s Songbook*, 34-35). Bear your testimony that Jesus came to earth to save us from sin and bring us joy.

ALMA 37:6-7

“By small and simple things are great things brought to pass.”

How can you teach the children to recognize that the Lord uses small or simple things to accomplish His work?

Possible Activities

- Read Alma 37:6-7, and invite the children to crouch down every time you read the word “small.” Show them a few small things that can make big things happen or move big things, such as a battery or a car key. What big things happen or move because of these small things? Help the children think of some small or simple things God wants us to do. What big things can happen because of these small or simple commandments?
- Show a picture or two of small things that accumulate into big things, such as a blade of grass and a field, or a raindrop and a lake. Testify that even small, simple actions can make a big difference in our lives and in the lives of others. Encourage the children to talk about some simple, good things they do every day, or share your own examples. Invite the children to pick one simple, good thing they can do this week and to draw a picture of themselves doing it. Invite them to take their drawings home and share them with their families.

ALMA 37:38-47

The scriptures can help us every day.

Though many young children can’t read, you can help them gain a testimony of the power of the scriptures to guide their everyday lives.

Possible Activities

- Display a picture of the Liahona (such as *Gospel Art Book*, no. 68), or invite the children to draw one while they share what they remember about it (see 1 Nephi 16:10, 28-29). Hold up the scriptures, and ask the children to share how

the scriptures are like the Liahona. Use Alma 37:38-47 and this week’s activity page to add to this discussion.

- Sing together a song about scripture study, such as “Search, Ponder, and Pray” or “As I Search the Holy Scriptures” (*Children’s Songbook*, 109; *Hymns*, no. 277). What blessings of scripture study are mentioned in the song?



The scriptures teach us how to follow God.



**Teach the Doctrine:
Older Children**

ALMA 36

I can be “born of God” when I follow Jesus and repent of my sins.

“Conversion . . . is a change in our very nature. It is such a significant change that the Lord and His prophets refer to it as a rebirth” (“Conversion,” *Gospel Topics*, topics.ChurchofJesusChrist.org).

Possible Activities

- Review with the children the story of the conversion of Alma the Younger in Alma 36:6-21. Write on slips of paper words and phrases from these verses that describe how Alma felt, and put them on the board. Ask the children to sort the slips of paper into two groups: things Alma felt before

he remembered what his father taught about the Savior and things he felt after he remembered. Read together Alma 36:17–20, and testify to the children that Jesus Christ forgives us when we repent.

- Write *Born of God* and the following scripture references on the board: *1 John 4:7; Mosiah 5:7; 27:25–26; Alma 5:14; 22:15*. Help the children read the verses and look for phrases that describe what it means to be born of God. How does a person act after being born of God? How can we show that we have been born of God?

ALMA 37:6–9, 38–47

“By small and simple things are great things brought to pass.”

Help the children you teach see that reading the scriptures for even a short time each day can bring them great blessings.

Possible Activities

- Draw or display a bucket. How many drops of water would it take to fill the bucket? Help the children recognize that many small drops will be needed to fill the bucket. How does this relate to Alma 37:6–7? How is reading the scriptures like adding little drops of water to a bucket?
- Invite the children to look in Alma 37:6–9 for blessings that come from the “records,” or scriptures. As a class, make a list of what they

find. How has reading the scriptures blessed our lives? Share your testimony of the scriptures, and encourage the children to do the same.

- Show or display a picture of the Liahona (such as *Gospel Art Book*, no. 68), and ask the children to review what they remember about the Liahona from 1 Nephi 16:10, 28. Help the children read Alma 37:38–42. How did the Liahona work? How is this similar to the way the scriptures work? Read together verses 43–47 to help answer this question. Invite the children to complete the activity page as part of this activity.



Encourage Learning at Home

Encourage the children to share one reason they are grateful for the scriptures and to invite members of their families to do the same.

Improving Our Teaching

Help children become better learners.













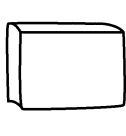
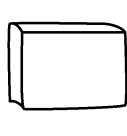



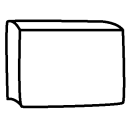

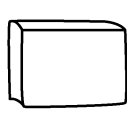



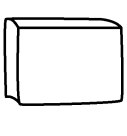

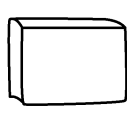



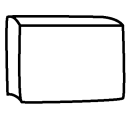

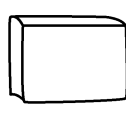



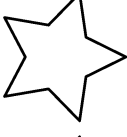
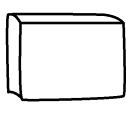

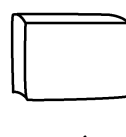

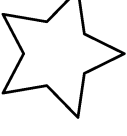
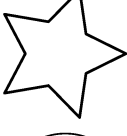
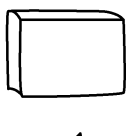



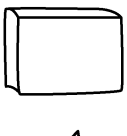

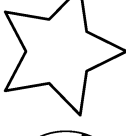
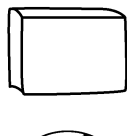
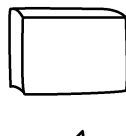

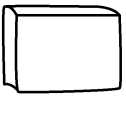

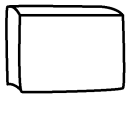



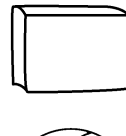
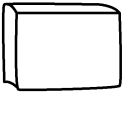

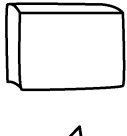



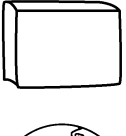

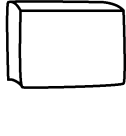

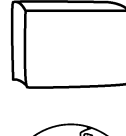

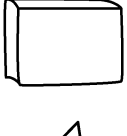

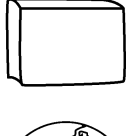

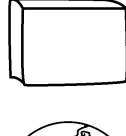

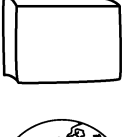

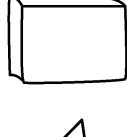

Your purpose in teaching children is not just to impart truth to them. You should also help them become self-reliant seekers of truth. For instance, instead of simply telling the children truths found in the story of Alma’s conversion, you could plan activities during which they can discover truths in the story for themselves.

The scriptures can lead us day by day (Alma 37:38-47).

Color the scriptures to see how they can lead us day by day to the Savior. Ask someone to share with you how the scriptures have led him or her to the Savior, and share how they have led you to Him.



Start
→

| | | | | | | |
|---|--|---|---|---|---|---|
|  |  |  |  |  |  |  |
|  |  |  |  |  |  |  |
|  |  |  |  |  |  |  |
|  |  |  |  |  |  |  |
|  |  |  |  |  |  |  |
|  |  |  |  |  |  |  |
|  |  |  |  |  |  |  |
|  |  |  |  |  |  |  |
|  |  |  |  |  |  |  |
|  |  |  |  |  |  |  |
|  |  |  |  |  |  |  |
|  |  |  |  |  |  |  |
|  |  |  |  |  |  |  |



Woman, Why Weepst Thou? by Mark R. Pugh

JULY 27–AUGUST 2

Alma 39–42

“THE GREAT PLAN OF HAPPINESS”

After prayerfully studying Alma 39–42, plan activities to help the children learn. You may find ideas among the following activities that can be adapted to any age-group.

RECORD YOUR IMPRESSIONS _____



Invite Sharing

Invite each child to stand up and share something about the gospel he or she has learned recently at home or at church.



Teach the Doctrine: Younger Children

ALMA 39:1, 10–11

I can be a good example.

Alma encouraged Corianton to learn from the good example of his brothers and warned Corianton not to be a negative example for others.

Possible Activities

- Explain that Shiblon and Corianton were brothers and that Shiblon was a good example for Corianton. Invite the children to repeat this question with you: “Has he not set a good example for thee?” (Alma 39:1). Ask the children to talk about someone who is a good example for them.
- Play a game or sing a song in which the children follow or imitate you, such as “Do as I’m Doing” (*Children’s Songbook*, 276). Let each child have a turn being the leader or example. Ask the children how they can be a good example to someone.
- Show pictures of Jesus doing good things, and explain that He is our perfect example. Explain that we can be good examples, like Jesus was. Invite the children to draw pictures of themselves being good examples.

ALMA 39:9, 13

Heavenly Father and Jesus Christ can help me correct my mistakes.

Even though young children do not need to repent, telling them about Corianton could help them begin to understand what repentance means.

Possible Activities

- Without going into detail about the nature of his sins, explain that Corianton made a wrong choice. What could we say to help him? Read to the children what Alma, Corianton’s father, said to him: “Ye should repent and forsake your sins” (Alma 39:9). Tell them that “repent” means that we ask Heavenly Father and Jesus Christ to forgive us and help us correct our mistakes and that we then try to be more like Them.
- Give a child something heavy to hold while you tell a story about someone who did something wrong and felt bad. Tell the children that the object is like the bad feelings we may have when we make a mistake. Take the heavy object from the child as you testify that Heavenly Father and Jesus Christ can take away the heavy, bad feelings and help us correct our mistakes when we repent. Sing together a song about repentance, such as “Repentance” (*Children’s Songbook*, 98).

ALMA 40:23

I will be resurrected.

Help the children look forward to the day when they and their loved ones will be resurrected.

Possible Activities

- While you read Alma 40:23 aloud, have the children use this week’s activity page to help them visualize what this verse is teaching. Invite each child to use the activity page to teach another child what resurrection is.

- Show a picture of the resurrected Savior, and teach the children a song about the Resurrection, such as “Did Jesus Really Live Again?” or “He Is Risen” (*Children’s Songbook*, 64; *Hymns*, no. 199). Pause periodically to explain the meaning and significance of the words and phrases.
- Ask the children if someone they know has died. Bear your testimony that someday that person and everyone else will be resurrected because of Jesus Christ. If needed, use this week’s activity page to explain what it means to be resurrected.



Mary and the Resurrected Lord, by Harry Anderson



**Teach the Doctrine:
Older Children**

ALMA 39:1, 10–11

I can be a good example.

Alma’s counsel to Corianton can help the children understand the importance of following and being good examples.

Possible Activities

- Explain that Alma’s son Corianton committed a serious sin while he should have been preaching the gospel. Read the last half of Alma 39:11 with the children, and ask them to listen for how Corianton’s sin affected the Zoramites. Help the

children think of people who may be influenced by their actions. How can they be good examples for these people?

- Read together Alma 39:1. How was Corianton’s brother Shiblon a good example? Ask the children to find additional answers to this question in Alma 38:2–4. Tell about some good examples in your life, and invite the children to do the same. Show the video “Lessons I Learned as a Boy” (ChurchofJesusChrist.org), and ask the children how the older boy was a good example.
- Bring a flashlight or a picture of the sun, and compare light to the power of a righteous example. Just as the light from a flashlight or the sun can help us see a path we need to follow, a righteous example shows us what to do in order to follow Heavenly Father. Share an experience when someone’s good example helped you. What can the children do to be a good example to others? Testify that Jesus Christ is our perfect example.

ALMA 39:9–13

I can repent when I make mistakes.

Just like all of us, the children you teach sin and make mistakes. How can you inspire them to “forsake [their] sins” and repent? (Alma 39:9).

Possible Activities

- Ask the children to share an experience when they got hurt. What did they do to help their injury heal? Explain that sin injures our spirits, but the Savior can heal us when we repent.
- Ask the children to find the phrase “repent and forsake your sins” in Alma 39:9, and help them understand what “repent” and “forsake” mean. Testify that repentance is possible through Jesus Christ and His Atonement. Read together Alma 39:10–14 to find other things we can do that will help us repent and avoid sin.

ALMA 40:6–7, 11–14, 21–23

After death, our spirits go to the spirit world until the Resurrection and Judgment.

It’s natural to wonder what happens to us after we die. Alma’s words can help the children find inspired answers.

Possible Activities

- Write *death*, *spirit world*, *resurrection*, and *judgment* on separate pieces of paper, and place them on the board in random order. Help the children understand what these terms mean. Read Alma 40:6–7, 11–14, and 21–23 with the children, and ask them to put the words on the board in the order in which they occur.
- Write on the board a list of questions that can be answered by Alma 40:6–7, 11–14, and 21–23, and invite the children to match each question with the verses that answer it. For example, “What will my body be like when I am resurrected?” can be answered by Alma 40:23. If necessary, explain difficult words to the children while they read. Encourage the children to share why they are grateful for Heavenly Father’s plan.



Encourage Learning at Home

Encourage the children to thank a family member who has been a good example to them and to think of one way they can be good examples this week.

Improving Our Teaching

Involve the senses. “Most children (and adults) learn best when multiple senses are involved. Find ways to help the children use their senses of sight, hearing, and touch as they learn” (*Teaching in the Savior’s Way*, 25).

I will be resurrected (Alma 40:23).

Cut out the physical body and the spirit body. Use a paper clip to show how our spirits join our physical bodies at birth, are separated at death, and reunite when we are resurrected.

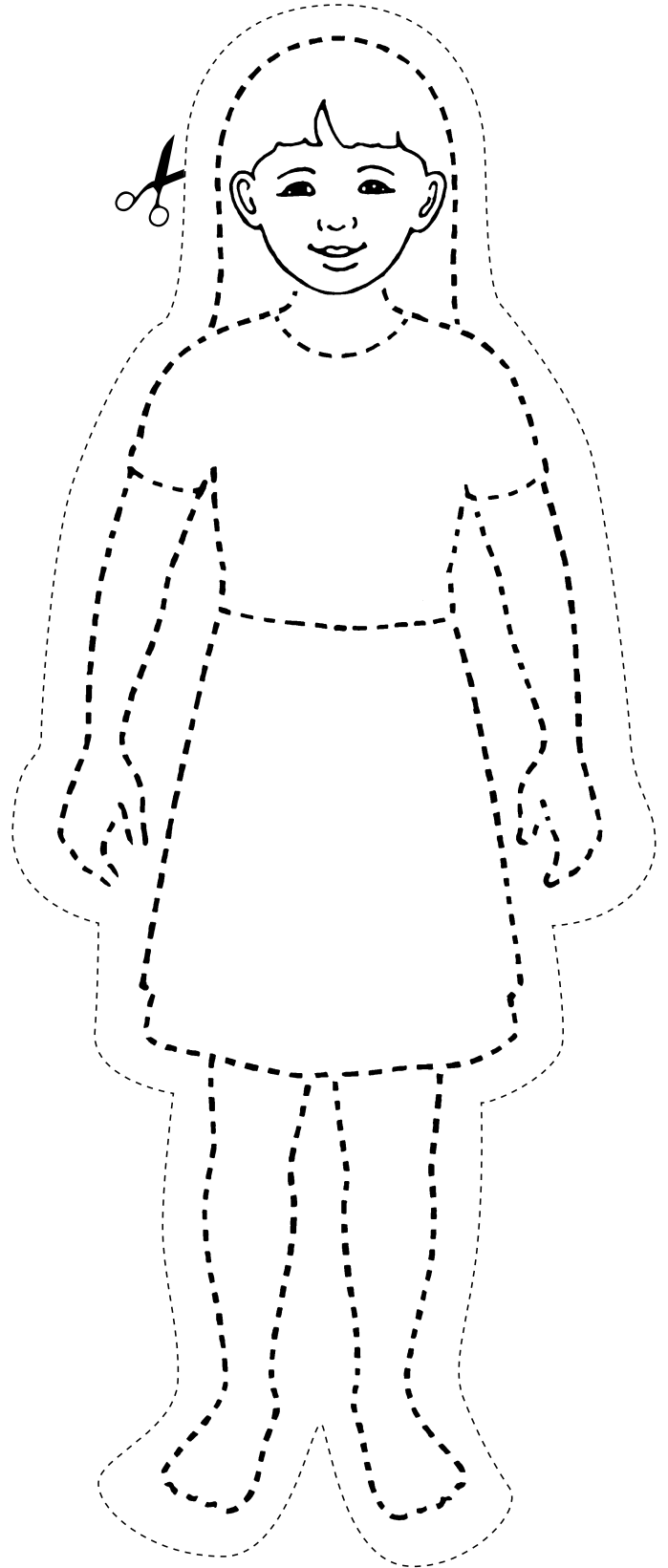
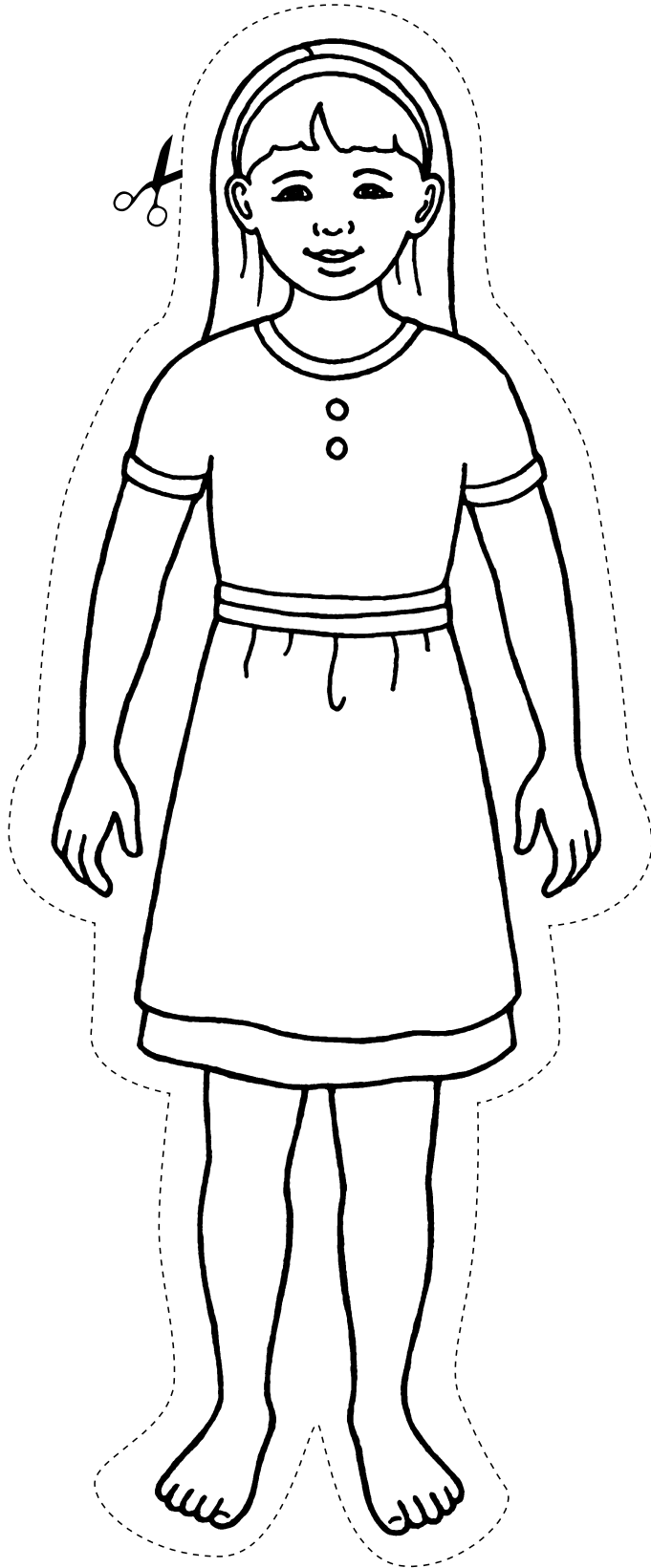



For the Blessings of Liberty, by Scott M. Snow

AUGUST 3-9

Alma 43-52

“STAND FAST IN THE FAITH OF CHRIST”

As you plan activities, you may find ideas here in the suggestions for teaching both younger children and older children.

RECORD YOUR IMPRESSIONS _____



Invite Sharing

Ask the children to share what they remember about some of the people and stories in Alma 43–52, such as Captain Moroni or the title of liberty. To help them remember, show pictures from *Book of Mormon Stories*, the *Gospel Art Book*, or *Come, Follow Me—For Individuals and Families*.



Teach the Doctrine: Younger Children

ALMA 43:17-21; 48:7-8; 49:1-5; 50:1-6

I can find spiritual protection in the gospel.

To defend the Nephites against the Lamanites, Moroni prepared his people with armor and

fortifications. His efforts teach us how we can find spiritual safety.

Possible Activities

- Tell the children a little about the war between the Nephites and the Lamanites (see Alma 43), emphasizing that the Nephites wore armor to protect themselves. You could use “Chapter 31: Captain Moroni Defeats Zerahemnah” (*Book of Mormon Stories*, 85–88, or the corresponding video on ChurchofJesusChrist.org). Read Alma 43:19, and invite the children to point to parts of their bodies as they hear them in the scripture.
- Explain that just as the Nephites were in a physical war, we are in a spiritual war against Satan, who doesn’t want us to keep God’s commandments. Draw a child on the board, and help the children think of things that protect us spiritually as armor protects our bodies (for example, prayer, scripture reading, or keeping the commandments). Each time something is mentioned, draw a piece of armor on the child on the board.



Minerva K. Teichert (1888–1976), *Defense of a Nephite City*, 1935, oil on masonite, 36 x 48 inches. Brigham Young University Museum of Art

ALMA 46:11–16; 48:11–13, 16–17

I can be faithful like Captain Moroni.

Moroni is a great example of faith, courage, and service. Consider how you can inspire the children to follow his example.

Possible Activities

- Show the picture of Moroni in this week’s outline in *Come, Follow Me—For Individuals and Families*. Tell the children about the title of liberty and what was written on it, using phrases from Alma 46:11–16. You could refer to “Chapter 32: Captain Moroni and the Title of Liberty” (*Book of Mormon Stories*, 89–90, or the corresponding video on ChurchofJesusChrist.org). Let the children help tell the story as much as possible. Point out that Moroni used the title of liberty to help the Nephites remember what was important to them.
- Help the children create a title of liberty for themselves or for your class. Begin by helping them think of things they believe in or things Heavenly Father wants them to remember. Let them draw pictures of these things on a large piece of paper, or you could bring pictures for them to attach to the paper.
- Ask the children to tell you about some people they want to be like and why they want to be like them. Then share with them some words from

Alma 48:11–13 that describe Moroni, and invite them to guess who these words are describing. Show a picture of Moroni, and talk about ways we can be like him.



Teach the Doctrine: Older Children

ALMA 43:17–21; 48:7–8; 49:1–5; 50:1–6

I can find spiritual protection in the gospel.

The world has many spiritual dangers, but there is much that the children can learn from the Nephites about how to protect themselves.

Possible Activities

- Invite each child to read silently one of the following verses that describe how the Nephites prepared for battle against the Lamanites: Alma 43:19; 48:8; 49:1–5; and 50:2–4. Ask the children to share what they learned (offer help if needed). Explain that we are in a spiritual war against Satan, and we must protect ourselves spiritually, just as the Nephites protected themselves physically from the Lamanites. What kinds of spiritual armor or fortifications can we build to protect ourselves in our spiritual battles?
- Help the children make a shield out of a large piece of paper or cardboard, and ask them to write on it things that protect us spiritually. Give each child a piece of paper, and invite the children to write something bad that Satan might tempt us to do (such as lie, steal, or be unkind). Ask them to crumple their papers into balls and throw them at the shield to illustrate how the gospel can keep us safe from Satan (see also Ephesians 6:16).

ALMA 46:11-16; 48:11-13, 16-17

I can be faithful like Captain Moroni.

Moroni was a faithful and strong disciple of Jesus Christ, who inspired the Nephites to live the gospel (see Alma 48:17). What can the children in your class learn from his example?

Possible Activities

- Read together Alma 46:11–16. What did Moroni want the Nephites to remember? (see verse 12). How did he help them remember these things? Ask the children to list some things Heavenly Father wants us to remember. Let the children design their own “titles of liberty” with phrases or pictures that will help them remember these things.
- Ask a child to read Alma 48:17. To help the children understand why we are invited to be like Moroni, invite them to study Alma 48:11–13, 16. Ask them to find words and phrases that help us understand why Moroni was such a great disciple of Jesus Christ. As they share what they find, encourage them to think of specific things they can do to be more like Moroni.

ALMA 47:4-19

Satan tempts and deceives us little by little.

Children need to know that Satan will try to tempt us to commit small sins so that he can lead us into greater sin.

Possible Activities

- Read together selected verses from Alma 47:4–19, and explain to the children how Amalickiah gained control of Lehonti’s army, even though

the members of the army were “fixed in their minds” that they would not be forced to fight the Nephites. What would have happened if Amalickiah had told Lehonti what he planned to do from the beginning? What do these verses teach us about how Satan tries to deceive us?

- Show a picture of a house that is well maintained and a house that has been neglected, or show a picture of a healthy garden and a garden full of weeds. Let the children talk about what they see in the pictures and how these changes might have happened over time. What could the owner of the house or garden have done to prevent this? Explain that people can gradually become sinful if they do not resist Satan’s temptations to commit small sins (such as being dishonest or looking at pornography) and then bigger sins. What are some bad things that we need to resist doing in our lives?



Encourage Learning at Home

Ask each child to name one thing he or she heard or felt today and wants to share with a family member. Encourage them to follow through with their plans.

Improving Our Teaching

Help the children build confidence. Some children may not feel capable of learning the gospel on their own. One way to build their confidence is to praise them when they participate in class.

I can find spiritual protection in the gospel (Alma 48:7-8; 49:1-5; 50:1-6).

Color the picture of the Nephite fort, and cut the picture into pieces along the solid lines. Put the picture together with someone, and talk about ways you can protect yourself from spiritual danger.

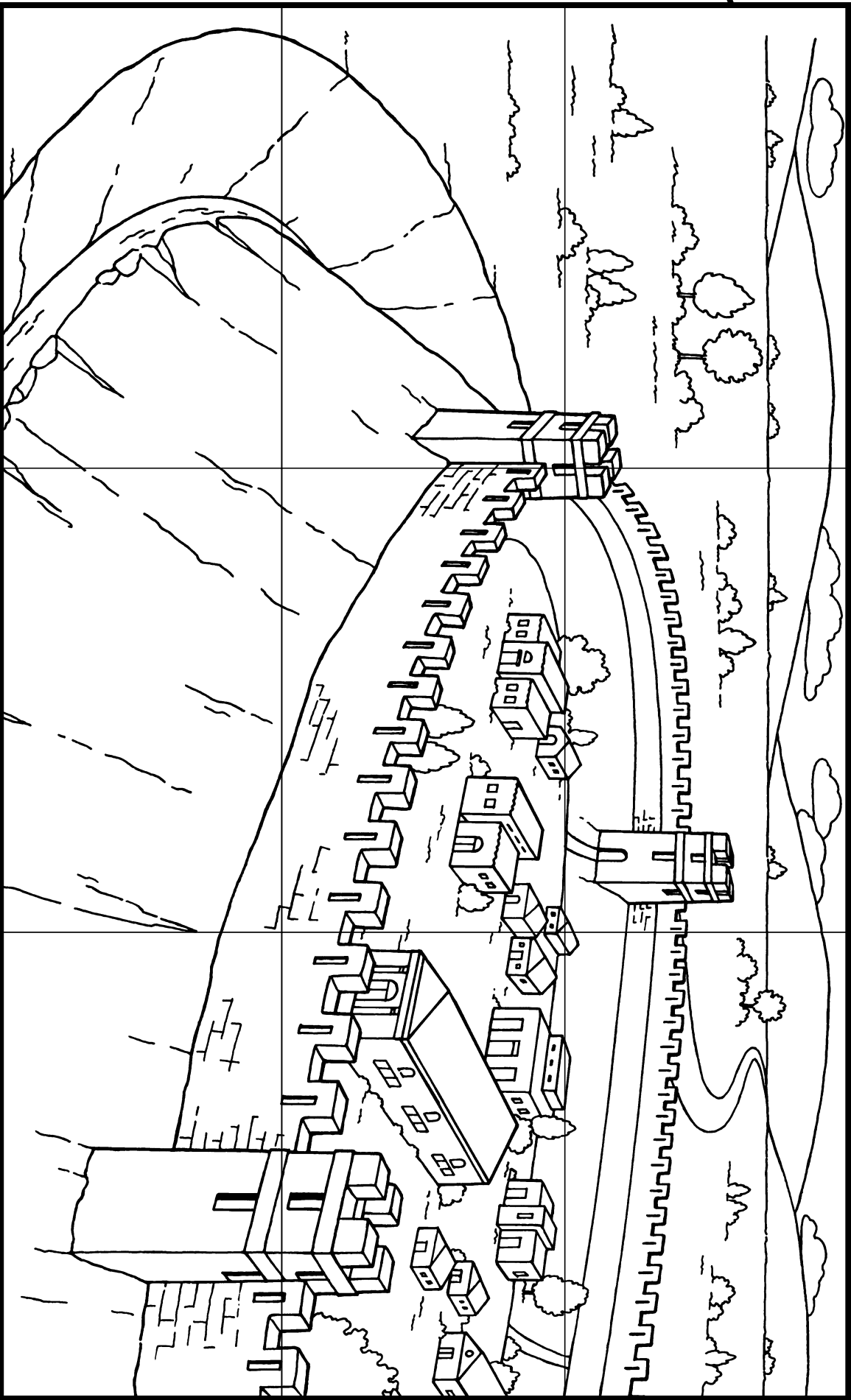



Two Thousand Young Warriors, by Arnold Friberg

AUGUST 10-16

Alma 53-63

“PRESERVED BY HIS MARVELOUS POWER”

As you read Alma 53-63, think about how you might bring the stories in these chapters to life for the children and help them learn the gospel principles that the stories teach.

RECORD YOUR IMPRESSIONS _____



Invite Sharing

To prepare the children to learn from Alma 53-63, invite them to share what they remember about the Anti-Nephi-Lehies (see Alma 23-24). To help, show a picture you used to teach the story, or remind them of an activity they did in class.



Teach the Doctrine: Younger Children

ALMA 53:20-21; 56:27, 47-48

I can be faithful to God like the stripling warriors.

Helaman’s stripling (meaning “young”) warriors can be a great example for the children in your class. Encourage the children to try to become like them.

Possible Activities

- Invite a child to hold up the picture in this week’s outline in *Come, Follow Me—For Individuals and Families* as you summarize the story of Helaman’s stripling warriors. You might also use “Chapter 34: Helaman and the 2,000 Young Warriors” (*Book of Mormon Stories*, 93-94, or the corresponding video on ChurchofJesusChrist.org). Let the children share what they know and like about the story of the 2,000 stripling warriors.
- Invite a girl and a boy to represent the mothers and fathers of the stripling warriors. As you read Alma 56:27 and 47-48, give these children items to hold that represent how the mothers and fathers helped the warriors, such as a sack of food to represent the “provisions” the fathers sent and scriptures to represent the mothers’ teachings. Ask the children to share things their parents provide for them or teach them.
- Read Alma 53:20-21, and help the children understand what words like *valiant*, *courage*, *strength*, and *true* mean. Describe how the stripling warriors showed these qualities. Make simple name tags for the children that read, “When I am _____, I am

like a stripling warrior!” Help the children fill in the blank with a quality they choose from Alma 53:20–21.

- Invite the children to complete this week’s activity page. Help them think of ways they can be like the army of Helaman. Sing together “We’ll Bring the World His Truth” (*Children’s Songbook*, 172–73).



Seed of Faith, by Jay Ward

ALMA 58:32–41

When I am worried, I can trust God.

When he and his armies faced hard times, Helaman trusted the Lord. What can the children you teach learn from his example?

Possible Activities

- Draw a frowning face on the board, and talk about how Helaman was worried because his army didn’t have enough food or enough men to keep fighting (see Alma 58:32–41). Ask the children to share times when they were worried. Read Alma 58:37 (or help a child read it), and help the children change the face on the board to a smiling face to show how Helaman felt because he trusted God. What can we do when we feel worried? Sing together “Smiles” (*Children’s Songbook*, 267).
- Write on some slips of paper a few things that children might worry about. Let the children take turns choosing a paper for you to read, and invite

the children to share how God could help them with each of these worries. Share an experience in which God helped you when you were worried.



Teach the Doctrine: Older Children

ALMA 56:45–48; 57:21, 25–27; 58:39–40

I can be faithful to God like the stripling warriors.

What truths from the story of Helaman’s stripling (meaning “young”) warriors can help the children with the challenges they are facing?

Possible Activities

- Invite the children to share what they know about the stripling warriors. You could also use “Chapter 34: Helaman and the 2,000 Young Warriors” (*Book of Mormon Stories*, 93–94, or the corresponding video on ChurchofJesusChrist.org). Let the children share what they admire about the warriors.
- Read together Alma 56:45–48; 57:21, 25–27; and 58:39–40. Invite the children to find words and phrases from these verses that describe the stripling warriors. What do these words and phrases mean? How can we be like the stripling warriors?
- Read Alma 56:46–48 to the children, and invite them to listen for what the mothers of the stripling warriors taught their children about faith. How do parents today help their children to have faith? Why is it important for children to follow the righteous teachings of their parents and Church leaders with “exactness”? (Alma 57:21).

ALMA 53:10–17; 56:27**I can keep my covenants.**

The stripling warriors and their parents made covenants that they fulfilled faithfully. You could use this account to teach the children about the importance of covenants.

Possible Activities

- Divide the children into three groups: one to represent Helaman, another to represent the people of Ammon, and the third to represent the sons of the people of Ammon. Read Alma 53:10–17 together, and let the groups share how the people they represent made and kept covenants. Share your testimony that Heavenly Father blesses us when we keep our covenants.
- Write on the board phrases from Mosiah 18:8–10 or Doctrine and Covenants 20:37 that describe things we covenant to do when we are baptized. Also write some other phrases not related to covenants. Ask the children to circle the things we covenant to do (let them use the scriptures if needed). How are we blessed when we keep our covenants? Encourage the children to write down what they have covenanted with God to do and display their list where they can see it often.
- Invite a child to read Alma 56:27. How did the fathers help their sons without breaking their covenant not to fight? Who supports us in keeping our covenants?

ALMA 61:3–14**I can choose to not be angry.**

Moroni falsely accused Pahoran, but instead of getting angry, Pahoran said, “I . . . rejoice in the greatness of your heart” (Alma 61:9).

Possible Activities

- Invite the children to think about a time when they were accused of doing something they didn’t do. Tell them about how this happened to Pahoran (see Alma 60–61). You might use “Chapter 35: Captain Moroni and Pahoran” (*Book of Mormon Stories*, 95–97, or the corresponding video on ChurchofJesusChrist.org). To learn about how Pahoran reacted, take turns reading verses from Alma 61:3–14. What did Pahoran do when Moroni accused him? What do we learn about forgiveness from Pahoran’s example? How can we be like him?
- Write on the board *What should I do when someone gets angry with me?* Invite the children to take turns writing some answers on the board. How might Pahoran have answered this question? Ask the children to write these answers in a letter to themselves that they can read when someone gets angry at them.

**Encourage Learning at Home**

Encourage the children to share with their families one way they want to be like the stripling warriors. They could also thank their parents for teaching them like the stripling warriors’ mothers did.

Improving Our Teaching**Engage children in gospel discussions.**

Altering the classroom setting can sometimes help children better engage in gospel discussions. For example, you could occasionally invite the children to sit in a circle on the floor rather than on their chairs.

I can be faithful to God, as the stripling warriors were (Alma 53:20-21).

Draw yourself as one of the stripling warriors. Share with someone how you can show your faith in Heavenly Father and Jesus Christ.

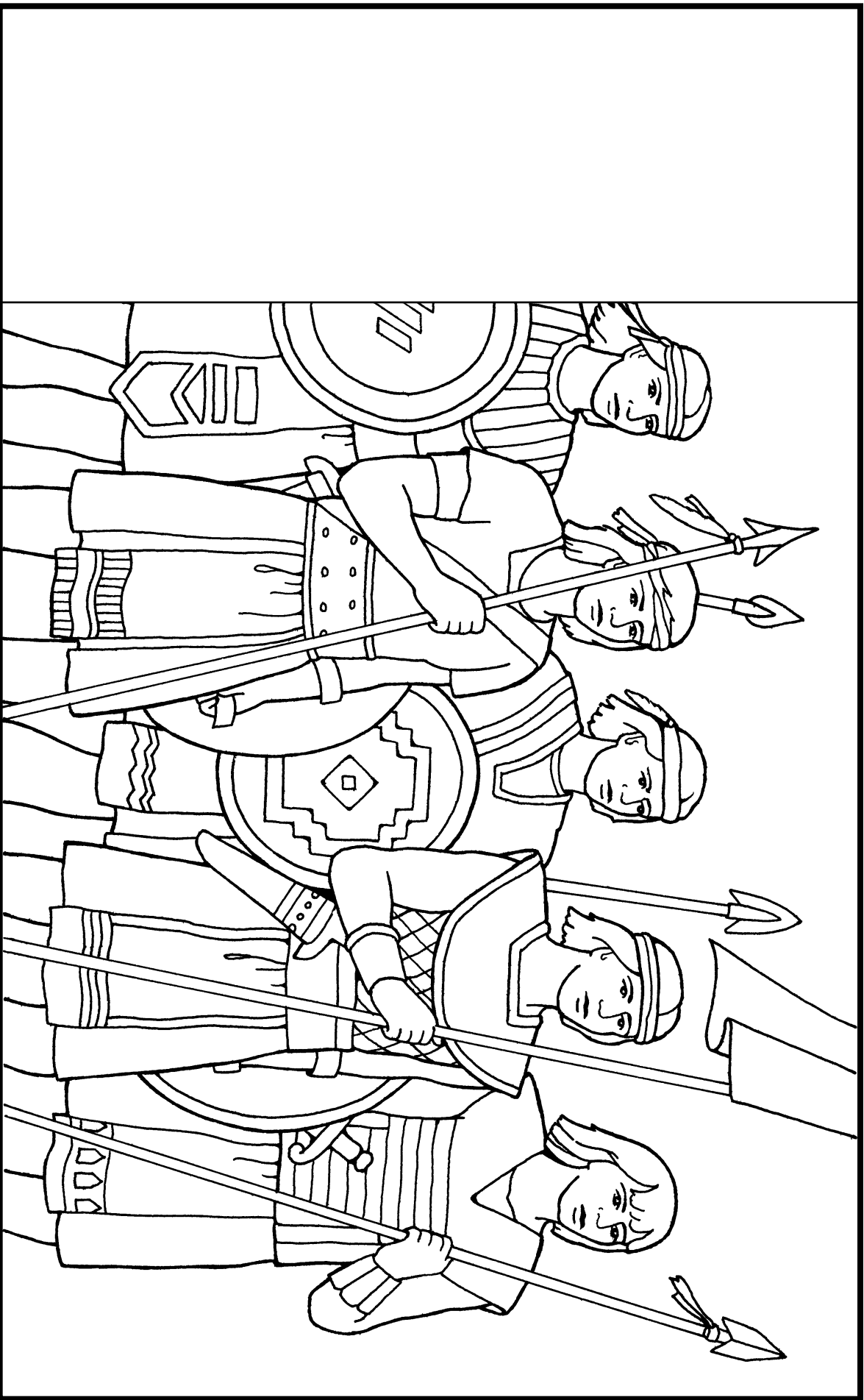



AUGUST 17-23

Helaman 1-6

“THE ROCK OF OUR REDEEMER”

The activities in this outline are intended to spark ideas and inspiration in your heart and mind. The best ideas usually come as you prayerfully ponder the scriptures and the needs of the children you teach.

RECORD YOUR IMPRESSIONS _____



Invite Sharing

To support children in their gospel learning at home, invite some of them to share something they learned this week. Describe how you study the gospel at home, and talk about ways the children could help their families learn from the Book of Mormon.



Teach the Doctrine: Younger Children

HELAMAN 5:12

I can build my foundation on Jesus Christ.

Helaman taught his sons Nephi and Lehi to build their lives on the rock of our Redeemer. Ponder how you will do the same for the children you teach.

Possible Activities

- Show a picture of a temple or another building, and explain that buildings need strong foundations so they won't fall down in wind and storms. To illustrate this, invite the children to try to move a rock by blowing on it. Read the first few lines of Helaman 5:12, and ask the children to raise their hands when they hear who the “rock” is that should be our foundation.
- Invite the children to do actions as you read Helaman 5:12. For example, they could wave their arms when you read about the devil's “mighty storm” and stand in one place when you read about the “rock of our Redeemer.”
- Invite the children to help you build a structure using blocks or other materials. Begin by forming a “sure foundation,” and talk to them about how Jesus Christ should be the foundation of our lives. Ask the children to share things they can do to follow Jesus Christ, and let them add a block to the structure's foundation for each thing they share.

- Invite children to color the activity page, and help them cut it out. What can we do to build our lives on the foundation of Jesus Christ? Share some of the ways you have built your life on the Savior and how doing so has blessed your life.

HELAMAN 5:21-52

The Holy Ghost whispers with a still, small voice.

The description in Helaman 5:29–30 and 45–47 of the voice that the Lamanites heard is similar to the way we often describe how the Holy Ghost speaks. You can use these verses to help the children recognize the voice of the Spirit.

Possible Activities

- Share the account of Nephi and Lehi in prison. You might use “Chapter 37: Nephi and Lehi in Prison” (*Book of Mormon Stories*, 99–102, or the corresponding video on ChurchofJesusChrist.org). When you talk about the voice the Lamanites heard, speak in a soft voice. Repeat the story a few times, and invite the children to whisper with you. Tell the children about times when the Holy Spirit has whispered to you and strengthened your testimony.
- Read Helaman 5:30, and sing with the children a song about the Holy Ghost, such as “The Still Small Voice” (*Children’s Songbook*, 106–7). Point out words in the scripture verse and the song that describe how the Holy Ghost speaks to us (see also Helaman 5:45–47). Use Helaman 5:29 and your own experiences to share with the children a few examples of good things the Holy Ghost can inspire us to do.



**Teach the Doctrine:
Older Children**

HELAMAN 1-6

When I am humble, Heavenly Father will bless me.

The Book of Mormon contains many examples of the dangers of pride and the blessings of humility, and several of these examples appear in Helaman 1–6. As you study these chapters, ponder how you can use these examples to teach the children in your class.

Possible Activities

- Let the children help you draw on the board the following diagram of the “pride cycle.” Read together Helaman 3:24, 33–34 and 4:11–15, and invite the children to point to the parts of the cycle these verses describe.
- Write the words *Humble* and *Prideful* on the board. Write a few examples of humble or prideful actions on slips of paper, and invite the children to take turns selecting a paper and putting it next to the word on the board that describes that action. What are some of the ways we can choose to be humble?



The “pride cycle.”

HELAMAN 5:5-14**I will build my foundation on Jesus Christ.**

Helaman 5:12 contains powerful images of building our foundation on Jesus Christ. How can you use these images to illustrate this principle to the children? Doing so will help prepare the children for the temptations and trials they will face.

Possible Activities

- Bring to class a few kinds of materials that can represent weak or strong foundations (such as cotton balls or a flat stone or tile). Invite the children to build a tower using blocks or other materials on the different kinds of foundations. What makes some foundations stronger than others? Read together Helaman 5:12, and ask the children why they think Jesus Christ is “a sure foundation” for our lives. How can we build our lives on Him? Invite them to search Helaman 3:27–29 and 35 and Articles of Faith 1:4 to find ideas.
- Invite the children to scan Helaman 5:5–14 and count how many times the word “remember” is mentioned. What did Helaman teach his sons that they should remember? How can remembering these things help us make Jesus Christ the foundation of our lives?

HELAMAN 5:20-52**Repentance replaces spiritual darkness with light.**

The Lamanites who went to the prison to kill Nephi and Lehi were surrounded by literal darkness. When we sin, we are in spiritual darkness. Helaman 5:20–52 teaches us how our spiritual “cloud of darkness” can be lifted (verse 41).

Possible Activities

- Make the classroom as dark as possible; then read or summarize the account in Helaman 5:20–40 using a small flashlight. How might the Lamanites have felt while in the dark? Invite the children to listen for what Aminadab taught the people to do so that the darkness would be lifted, and then read verse 41. Then turn the lights on, and read verses 42–48 together. What do these verses teach us about the blessings that repentance brings to our lives?
- Invite the children to imagine that they are teaching a younger child about the Holy Ghost. How could they use Helaman 5:29–33, 44–47 to teach what the voice of the Spirit feels like and some of the things the Spirit tells us? How has the Holy Ghost inspired you to repent? Invite the children to share experiences when they have felt the peace and comfort of the Holy Ghost.

**Encourage Learning at Home**

Invite the children to ask family members about how they have built their lives on Jesus Christ. Or they could share with their families how they plan to build their own lives on Him.

Improving Our Teaching

Testify of Jesus Christ. You have a sacred opportunity to help strengthen the growing testimonies of the children in your class. Help them to feel Jesus’s love for them, and bear your testimony of Him often.

I will build my foundation on Jesus Christ (Helaman 5:12).

Make a pop-up house. Color the pictures, and cut out the rectangle and the house. Fold the rectangle in half on the dotted line. Fold the dotted lines on the bottom of the house, and glue the marked tab to the back of the house as illustrated below. Glue the house to the rectangle by matching the numbered sections. Write in the square ways you can build your foundation on Jesus Christ.

1.

2.

I can build my foundation on Jesus Christ by:

Jesus Christ is my foundation.

2.

1.

1.



Illustration of Nephi in a garden tower by Jerry Thompson

AUGUST 24-30

Helaman 7-12

“REMEMBER THE LORD”

As you read Helaman 7-12, ponder how the stories and principles in these chapters can bless the children you teach. The ideas in this outline can supplement the inspiration you receive.

RECORD YOUR IMPRESSIONS _____



Invite Sharing

Ask the children what they know about the prophet Nephi, the son of Helaman (see Helaman 7-12). If needed, explain the difference between this prophet named Nephi and the prophet named Nephi at the beginning of the Book of Mormon.



Teach the Doctrine: Younger Children

HELAMAN 7:20

The Lord wants me to remember Him.

Nephi wondered how his people had turned away from God and forgotten Him. How can you help the children learn ways they can remember Heavenly Father and Jesus?

Possible Activities

- Share with the children an experience when you forgot something important. Ask them if they have ever forgotten something. Read to them Helaman 7:20, and explain that the Nephites had chosen to forget about God. The prophet Nephi wanted them to remember God. Bring pictures in a bag that represent ways the children can remember Heavenly Father and Jesus. Let the children take turns choosing a picture and sharing how we can remember God every day.
- Help the children complete this week's activity page.

HELAMAN 8:13-23

Prophets testify of Jesus Christ.

Nephi testified that Jesus Christ would come, and he invited his people to repent and follow Him. Use these chapters to teach the children that prophets testify of Jesus Christ.

Possible Activities

- Show a picture of Jesus Christ, and tell the children that prophets like Nephi invite us to follow

Jesus. Read the following words about prophets from Helaman 8:22: “They have testified of the coming of Christ, and have looked forward, and have rejoiced in his day.” Share with the children something our living prophet has said about the Savior.

- Sing together a song about prophets, such as “Follow the Prophet” (*Children’s Songbook*, 110). Pick a key phrase from the song, and write one word from the phrase on each of several paper footprints. Lay the footprints on the floor leading to a picture of the Savior. Invite the children to follow the path of the footprints, and help them read the words.

HELAMAN 10:11–12

I will obey Heavenly Father.

Nephi’s example of obedience can inspire the children you teach to obey the Lord.

Possible Activities

- Read Helaman 10:2, 11–12, and help the children understand that Nephi obeyed God. Invite the children to act out what Nephi did. For example, ask them to walk toward one side of the room (as if they are going home), stop, turn around, and walk toward the other side of the room (as if they are returning to teach the people). Help them see that Nephi wanted to obey the Lord even though he had to do something difficult.
- Help the children understand that sometimes Heavenly Father wants us to do something that is different from what we want to do, but we can obey Him like Nephi did. Share statements like “Sometimes I want to get angry, but Heavenly Father wants me to be . . . ,” and let the children finish the statements. Encourage the children to remember to stop and think about what Heavenly Father wants them to do and then do it.



Teach the Doctrine: Older Children

HELAMAN 7–11

I will be spiritually safe as I follow the prophet.

President James E. Faust taught: “Our safety lies in paying heed to that which [the President of the Church] says and following his counsel” (“Continuous Revelation,” *Ensign*, Nov. 1989, 10).

Possible Activities

- Invite the children to make a list on the board of things a prophet does (see “Prophet,” Guide to the Scriptures, scriptures.ChurchofJesusChrist.org). Help them search Helaman 7:1–2, 27–29; 8:22–23; and 10:3–4, 6–7 to see how Nephi did some of the things in their list. When have we seen our prophet today do these things? Bear your testimony of the living prophet. To illustrate the importance of prophets, show the first minute of the video “Watchman on the Tower” (ChurchofJesusChrist.org).
- Read together Helaman 11:3–7 (or review “Chapter 39: Nephi Receives Great Power,” *Book of Mormon Stories*, 108–10, or the corresponding video on ChurchofJesusChrist.org). Ask the children to listen for what happened to the people who did not listen to the prophet. What can happen when we do not listen to the prophet? How are we blessed when we follow Him? Share something that our prophet has taught, and encourage the children to follow his teachings.

HELAMAN 7:20–21**The Lord wants me to remember Him.**

The children you teach will face distractions that could cause them to forget Heavenly Father and Jesus Christ. How can you inspire the children to devote time to spiritual things?

Possible Activities

- Read together Helaman 7:20–21, and ask the children what they think it means to forget God. Explain that the word *forget* can also mean “to neglect” or “ignore.” Display a picture of the Savior, and invite the children to draw things they might spend too much time doing that could cause them to forget the Lord. Put their drawings in front of the picture of Jesus. Ask the children to think of things they can do each day to remember Heavenly Father and Jesus. As they share their thoughts, take away the drawings one by one until the picture of the Savior is revealed.
- Invite the children to complete this week’s activity page.

HELAMAN 10**When I ponder the words of God, I can receive revelation.**

Do the children you teach know what it means to ponder? Help them understand that Nephi was blessed with revelation when he pondered the things the Lord had shown him.

Possible Activities

- Help the children understand what it means to ponder (see “Ponder,” Guide to the Scriptures, scriptures.ChurchofJesusChrist.org). Invite them

to think of other words that describe what *ponder* means. Then ask them to read Helaman 10:1–3 and replace the word *ponder* with the words they thought of. What happened when Nephi pondered the scriptures? (see Helaman 10:3–7). Share a time when you received revelation after pondering a scripture or a modern-day revelation or a spiritual experience.

- Give the children time to read Helaman 10, or read it together, and encourage them to find a verse they would like to ponder during the coming week. Invite them to write the verse they chose on a paper or card and put it somewhere to remind them to ponder that verse during the upcoming week. In a future class, give them time to share what they learned as they pondered the verse.

**Encourage Learning at Home**

Encourage the children to share with their families what they plan to do to remember Heavenly Father and Jesus Christ every day. They could also invite their families to join them in their goal.

Improving Our Teaching**Extend invitations that respect agency.**

When you invite children to act on what you have taught them, think of ways to honor their agency as they apply what they learn. For example, after a lesson about the Savior, you could ask, “What will you do to remember the Savior this week?”

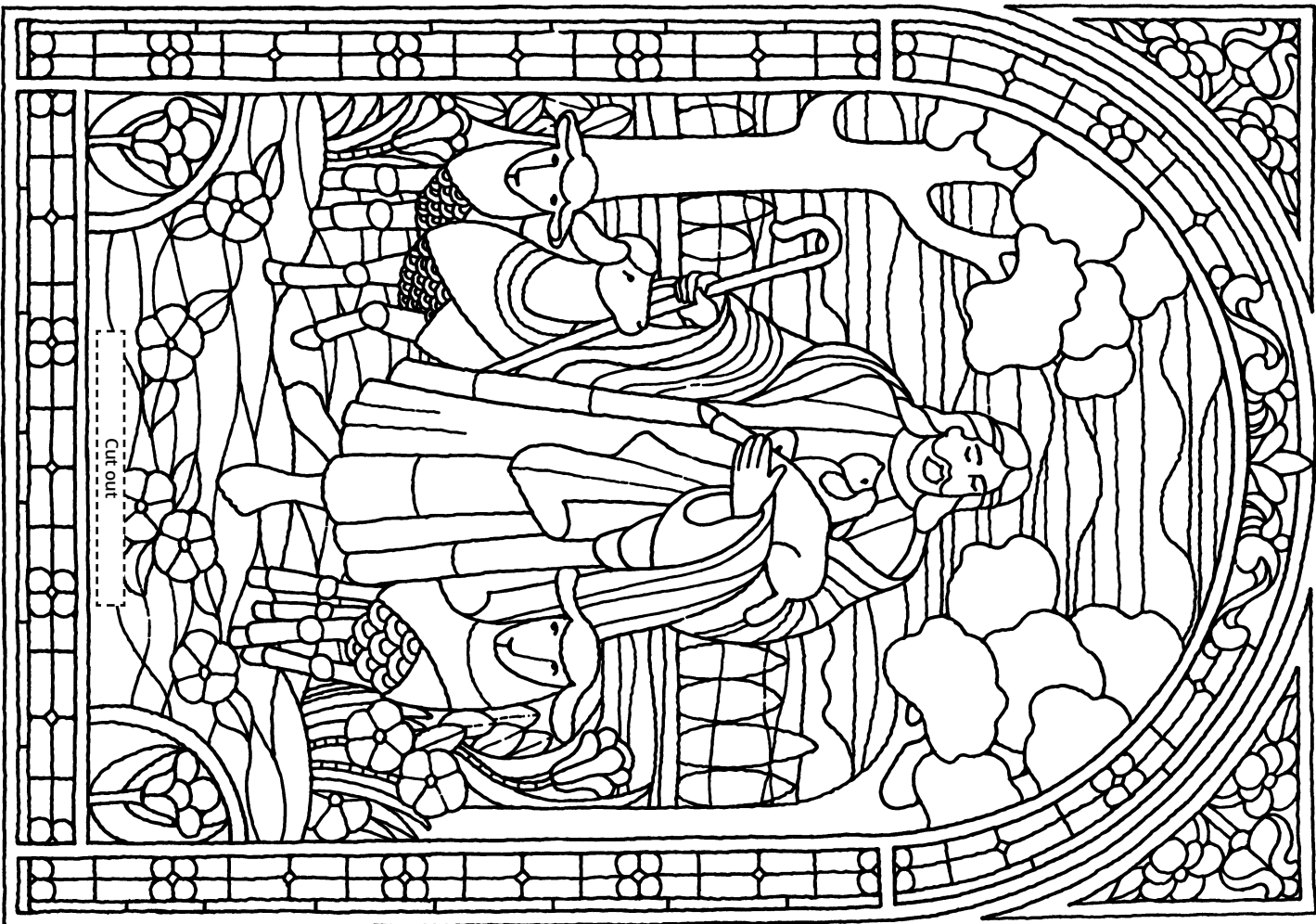

**The Lord wants me to remember Him
(Helaman 7:20).**

Color the picture, cut it out, and cut out the slit at the bottom. Then cut slips of paper to make a paper chain. Each time you do something to remember Jesus during the week, write what you did on a slip and add a link to your chain.

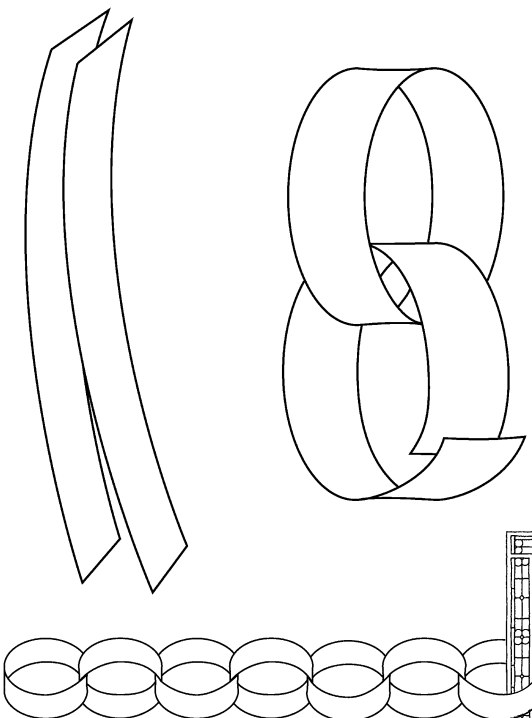



Samuel the Lamanite on the Wall, by Arnold Friberg

AUGUST 31–SEPTEMBER 6

Helaman 13–16

“GLAD TIDINGS OF GREAT JOY”

Prepare to teach by reading Helaman 13–16 and pondering which activities will best help the children learn the truths in these chapters.

RECORD YOUR IMPRESSIONS _____



Invite Sharing

Show a picture of Samuel the Lamanite, and invite the children to share something they know about him. For example, could they talk about the story of Samuel teaching on the wall or the signs he said would appear when Jesus was born?



Teach the Doctrine: Younger Children

HELAMAN 13:2–5

The Spirit can speak to our hearts.

When Samuel the Lamanite was commanded to preach to the Nephites, Heavenly Father helped him know in his heart what he should say.

Possible Activities

- Teach the children that while we speak to each other using words, the Holy Ghost can communicate through feelings in our hearts. Invite them to hold their hands over their hearts each time you read the word “heart” in Helaman 13:2–5. Help them decorate heart-shaped pieces of paper that say, “The Spirit speaks to me in my heart.”
- Tell the children that when they are baptized and confirmed, they will have the gift of the Holy Ghost to help them know what Heavenly Father wants them to do and say. Help them think of things the Holy Ghost might tell them, and invite them to share what they could do to follow His promptings.

HELAMAN 14:2–7, 20–25

Prophets teach about Jesus Christ.

The account of Samuel the Lamanite is a great opportunity to teach the children that all prophets teach about Jesus Christ.

Possible Activities

- Show the picture of Samuel the Lamanite in this week’s outline in *Come, Follow Me—For Individuals and Families*, and tell the children, in simple words, about his experience in Helaman 13–16. You could also use “Chapter 40: Samuel the Lamanite Tells about Jesus Christ” (*Book of Mormon Stories*, 111–13, or the corresponding video on ChurchofJesusChrist.org). Let the children share things they know about Samuel the Lamanite.
- Sing together “Samuel Tells of the Baby Jesus” or the seventh verse of “Book of Mormon Stories” (*Children’s Songbook*, 36, 118–19). Share something you admire about Samuel, and let the children share what they like about his story.
- Hide pictures around the room that represent the signs that Samuel prophesied of in Helaman 14:2–7 and 20–25. Read a phrase that describes one of the signs, and ask the children to find the picture of that sign. Explain that these signs helped the Nephites know about Jesus Christ. Testify that, like Samuel, all prophets testify of Jesus Christ.



The prophet points us to Jesus Christ.

HELANMAN 16:1–6

I am blessed when I follow the prophet.

Heavenly Father has given us a prophet to help us know His will and follow His plan. We are blessed as we listen to the prophet’s words and obey.

Possible Activities

- Help the children build a small wall with blocks or books. Using a small toy or doll to represent Samuel, let the children take turns helping “Samuel” climb the wall to teach the people about Jesus Christ. (See also this week’s activity page.) Share phrases from Helaman 16:1 and 5 to explain that some people believed Samuel and were baptized. Use phrases from Helaman 16:2 and 6 to show that others did not believe and were angry with Samuel. Testify that people who follow the prophet are blessed.
- Display a picture of the Savior, and ask a child to represent the prophet and lead the other children around the room while they sing a few verses of “Follow the Prophet” (*Children’s Songbook*, 110–11) or another song about prophets. Then ask the child representing the prophet to lead the children to the picture of the Savior. Testify that if we follow the prophet, he will lead us to Jesus Christ. Share some things our prophet has taught about Jesus recently. How can we follow his counsel?



Teach the Doctrine: Older Children

HELANMAN 13:2–4

The Spirit can speak to our hearts.

Someday, the children you teach will need to know how to do what Samuel did: share the message that the Lord puts in their hearts.

Possible Activities

- Show a picture of Samuel the Lamanite (such as the one in *Come, Follow Me—For Individuals and Families*), and ask the children how Samuel knew what to say when he was preaching from the

city wall. Invite them to search Helaman 13:2–4 for an answer. Tell about a time when the Holy Ghost helped you know in your heart what God wanted you to do or say. Ask the children to share any similar experiences they have had.

- Show a picture of the living prophet speaking in general conference. Tell the children that God tells the prophet what to say to us, just as He told Samuel what to say to the Nephites. Talk together about things the prophet has said that have been inspiring to you or the children.

HELAMAN 14:2–28

Prophets teach about Jesus Christ.

The purpose of Samuel’s message was to testify of Jesus Christ and invite the people to repent and come unto Him. Our prophets today have the same role.

Possible Activities

- Invite half of the children to read Helaman 14:2–6 and draw pictures of the signs of Jesus’s birth. Invite the other half of the class to read Helaman 14:20–28 and draw pictures of the signs of Jesus’s death. Then ask each group to share what they drew. Read together Helaman 14:11–12, and ask the children to listen for why Samuel prophesied about these signs. How do we learn about Jesus Christ today?
- Explain that just as Samuel the Lamanite taught about Jesus Christ, living prophets do the same today. Share a statement from a recent conference message in which the living prophet testified of Christ. Ask the children to share what the prophet has taught them about Jesus Christ.

HELAMAN 16:1–6

I am blessed when I follow the prophet.

Heavenly Father has given us a prophet to help us know His will and follow His plan. We are blessed as we listen to and obey the prophet’s words.

Possible Activities

- Read aloud Helaman 16:1 and 5, and ask the children to stand up when they hear something the people did when they believed Samuel’s words. Then read verses 2 and 6, and ask the children to sit down when they hear something the people did when they did not believe. How can we show that we believe the words of the living prophet?
- Show a picture of the living prophet, and ask the children to share what they know about him. Share how you are trying to follow his teachings and how doing so has blessed you.



Encourage Learning at Home

Invite the children to learn about something the prophet has said and share it with the class next week.

Improving Our Teaching

Encourage children to ask questions.

“Strive to see [the children’s] questions as opportunities, not as distractions or impediments to your lesson. . . . Such questions give you valuable insights into what the children are thinking, what concerns they have, and how they are responding to the things they are learning” (see also *Teaching in the Savior’s Way*, 25–26).

I am blessed when I follow the prophet (Helaman 16:1-8).

Color the pictures. Cut out the figure of Samuel the Lamanite, and attach a craft stick to the back. Cut a slit on the dotted line at the top of the wall, and insert the figure through the slit as you tell someone the story of Samuel the Lamanite on the wall.

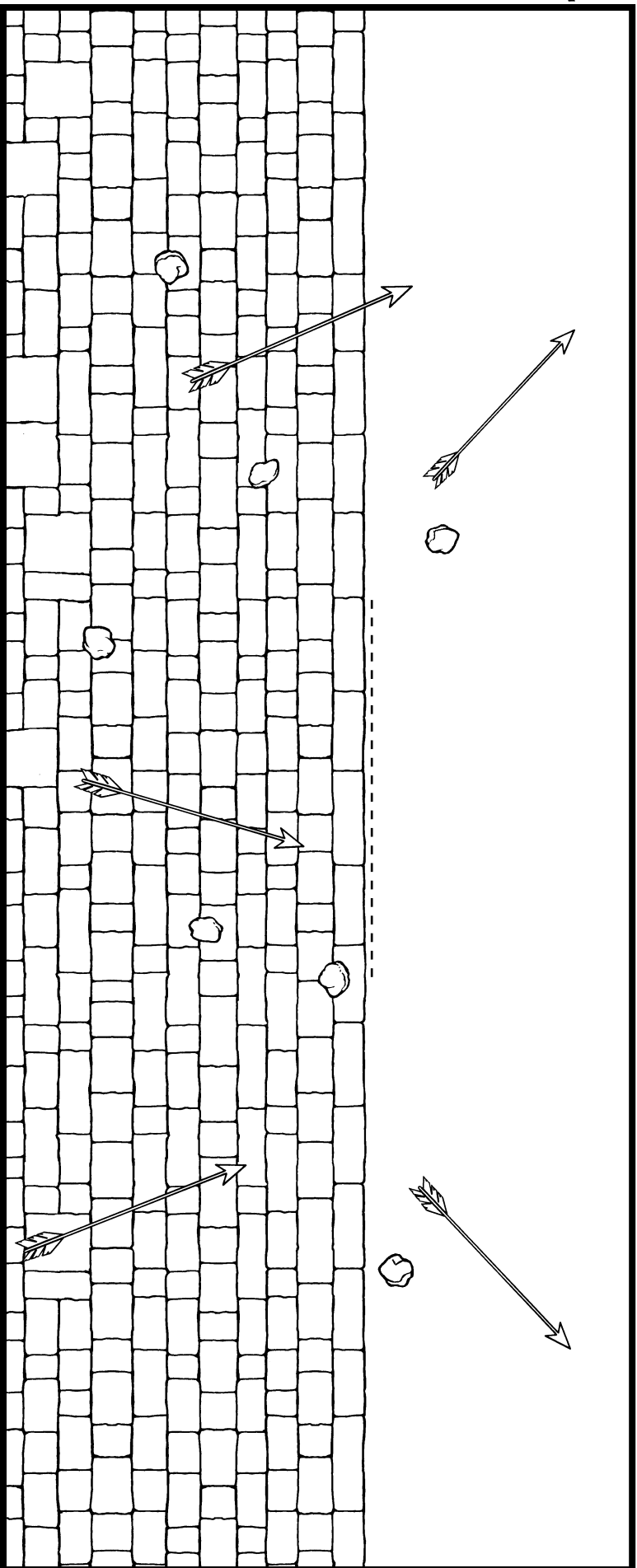
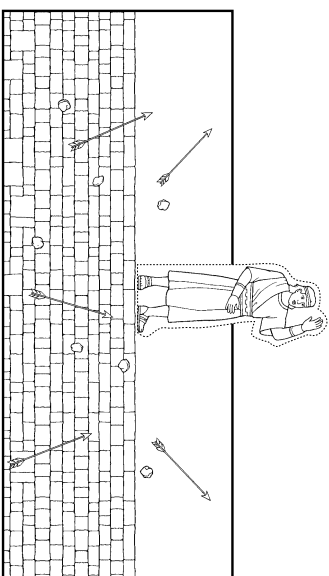
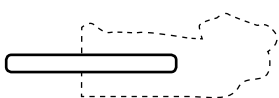
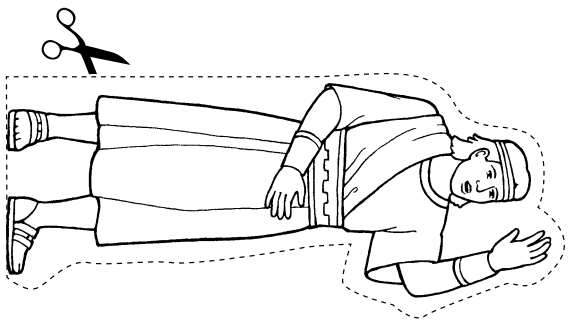



One Day, One Night, and One Day, by Jorge Cocco

SEPTEMBER 7-13

3 Nephi 1-7

“LIFT UP YOUR HEAD AND BE OF GOOD CHEER”

If you need additional ideas as you prepare to teach, see “Additional Resources for Teaching Children” and “Meeting the Needs of Younger Children” at the beginning of this resource.

RECORD YOUR IMPRESSIONS _____



Invite Sharing

Invite the children to share what they remember learning last week about the signs Samuel the Lamanite said would help the people know that Jesus was born. Tell the children that today they will talk about the people who saw those signs happen.



Teach the Doctrine: Younger Children

3 NEPHI 1:4-15, 19-21

A new star appeared when Jesus Christ was born.

The New Testament account of the Savior’s birth is well known, even by children. This week is a great

opportunity to teach the children in your class about the miracles the Nephites witnessed when Jesus was born.

Possible Activities

- Before class, place a star on the wall. Invite the children to look for something on the wall that usually isn’t there. Tell the children that the Nephites saw a new star in the sky when Jesus was born. Summarize the account in 3 Nephi 1:4–15 and 19–21. You could also use “Chapter 41: The Signs of Christ’s Birth” (*Book of Mormon Stories*, 114–16, or the corresponding video on ChurchofJesusChrist.org).
- Show the children a picture of the Savior’s birth (see *Gospel Art Book*, no. 30), and sing a favorite Christmas song, such as “The Nativity Song” (*Children’s Songbook*, 52–53). Help the children understand that the Nephites were far away from where Jesus was born, but they knew He was born because of the signs they saw. Testify that even though we did not see the Savior’s birth, the Holy Ghost can help us know that the stories about it in the scriptures are true.

3 NEPHI 1:20

The prophets' words are always fulfilled.

The Lord told Nephi, "I [will] show unto the world that I will fulfil all that which I have caused to be spoken by the mouth of my holy prophets" (3 Nephi 1:13).

Possible Activities

- Show pictures that depict how God has spoken through prophets, such as Noah (*Gospel Art Book*, nos. 7–8; see Genesis 6–7) and Samuel the Lamanite (*Gospel Art Book*, no. 81; see Helaman 14:1–7). Invite the children to share what they know about these stories.
- Read to the children 3 Nephi 1:20, and share your testimony that the words of prophets are always fulfilled. Invite the children to listen to the prophet at the next general conference.

3 NEPHI 5:13

I can follow Jesus Christ.

Mormon declared, "I am a disciple of Jesus Christ." How can you help the children see themselves as disciples too?

Possible Activities

- Read 3 Nephi 5:13, and invite the children to repeat the phrase "I am a disciple of Jesus Christ." Teach them that a disciple of Jesus Christ tries to follow Him. Share a few things Mormon did to be like Jesus, such as teaching God's word and obeying God's commandments (see 3 Nephi 5:13–18). Help the children think of ways they can be disciples.
- On a piece of paper, help the children trace their hand and cut it out. Write "I am a disciple of Jesus Christ" on one side, and invite them to draw something they can do to be a disciple on the other side (you might need to help them think of ideas). Sing together a song about

following the Savior, such as "I'm Trying to Be like Jesus" (*Children's Songbook*, 78–79).



Teach the Doctrine:
Older Children

3 NEPHI 1:4-21

God's promises, given through His prophets, are always fulfilled.

The account in 3 Nephi 1:4–21 can help build the children's faith that God always keeps His promises.

Possible Activities

- Invite the children to compare the prophecy of Samuel the Lamanite in Helaman 14:1–7 with its fulfillment in 3 Nephi 1:19–21. Testify that God's promises spoken through His prophets are always fulfilled.
- Read with the children the account found in 3 Nephi 1:4–10. Ask the children how they might have felt if they had been one of the believers living at that time. Invite the children to read the rest of the account in verses 11–15 and to suggest ways to complete this sentence: "The lesson of this story is . . ." How can we show our trust in God when we are worried or discouraged?
- Share something that our living prophet has promised us. What can we do to show our faith that the prophet's words came from God?

3 NEPHI 2:11-12; 3:13-14, 24-26

We are stronger when we gather together.

The Nephites had to gather together for physical safety. How can you help the children see that gathering together with righteous friends can also give them spiritual strength?

Possible Activities

- Read with the children the following verses, and invite them to look for reasons why the Nephites gathered together and the blessings that came to them: 3 Nephi 2:11–12 and 3:13–14, 24–26. Why is it important for us to “gather” today in our families and at church? How can gathering make us spiritually stronger?
- Use an object lesson to teach that we are stronger together than we are apart. For example, invite the children to try breaking one stick and then a bundle of sticks or tearing one piece of paper and then a stack of papers. How are we like the sticks or the paper? How can we strengthen each other when we gather together in our families or at church?
- Explain that Jesus is gathering His people into the Church today through missionary work (see 3 Nephi 5:24–26). Invite a full-time missionary or ward missionary to share experiences showing how people have been strengthened by being gathered into the Church.

3 NEPHI 4:30–33; 5:12–26; 6:14; 7:15–26

I am a disciple of Jesus Christ.

How can you help the children see themselves as disciples of Jesus Christ, as Mormon did? (see 3 Nephi 5:13).

Possible Activities

- Show a picture of Mormon (such as *Gospel Art Book*, no. 73). Invite each child to take a turn and repeat what Mormon said in 3 Nephi 5:13: “I am a disciple of Jesus Christ.” What does it mean to be a disciple of Jesus Christ? (see D&C 41:5).
- Divide the class into small groups, and assign each group to read about one of the following examples of disciples: the converted Lamanites (see 3 Nephi 4:30–33; 6:14), Mormon (see 3 Nephi 5:12–26), and Nephi (see 3 Nephi 7:15–26). How were these people true disciples of Jesus Christ? What can we do to follow their examples?



Encourage Learning at Home

Invite the children to think of something they will do this week to be disciples of Christ. Encourage them to write it down and share it with their families.

Improving Our Teaching

Display a scripture. Select a verse you find meaningful (or invite the children to select one), and display it in your classroom where the children will see it often. You might display it for several weeks and refer to it occasionally.

A new star appeared when Jesus was born (3 Nephi 1:4-15, 19-21).

In the first rectangle, draw the signs of the Savior's birth the Nephites saw in the sky (see 3 Nephi 1:19-21).

In the second rectangle, draw the sign of the Savior's birth the Wise Men saw (see Matthew 2:1-10).

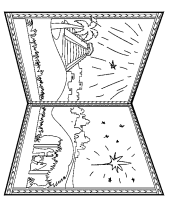

The image shows a large rectangular area divided into two horizontal sections by a central line. The top section contains a drawing of a city with a large temple on a hill and a palm tree. The bottom section contains a drawing of a city with a church spire and a star in the sky. The entire area is framed by a decorative border with a repeating zig-zag pattern. A pair of scissors icon is located at the top right corner of the page.



I Am the Light of the World, by James Fullmer

SEPTEMBER 14-20

3 Nephi 8-11

“ARISE AND COME FORTH UNTO ME”

Read 3 Nephi 8–11 with the children you teach in mind. The ideas in this outline can help guide your preparation.

RECORD YOUR IMPRESSIONS _____



Invite Sharing

Show a picture of Jesus Christ appearing in the Americas, like the one in this week’s outline in *Come, Follow Me—For Individuals and Families*. Invite the children to point out details in the picture and share something they know about the story being depicted.



Teach the Doctrine: Younger Children

3 NEPHI 8-11

Jesus Christ invites me to come to Him.

You may not be able to share with the children all the details of the Savior’s appearance to the people of Nephi, but you can help them feel the love He showed the people in 3 Nephi 8–11.

Possible Activities

- Tell the children about the storms and darkness described in 3 Nephi 8, being careful not to scare or upset them. You could use “Chapter 42: The Signs of Christ’s Crucifixion” (*Book of Mormon Stories*, 117–19, or the corresponding video on ChurchofJesusChrist.org). Ask the children how they might feel if they had been in those storms and darkness. Explain that the storms and darkness were signs that Jesus had died, and show a picture of the Crucifixion (see *Gospel Art Book*, no. 57). Then read 3 Nephi 9:13. What did Jesus say He would do for those who repented? Help the children understand that the word “heal” in this verse means that Jesus would forgive them.
- Display the picture in this week’s outline in *Come, Follow Me—For Individuals and Families* while you describe in your own words the resurrected Savior’s appearance to the Nephites and Lamanites. Read short passages from 3 Nephi 11 that will help them feel the sacredness of this event. Invite them to close their eyes and imagine how they would feel if they got to see Jesus. Or show the first minute of the video “My Joy Is Full”

(ChurchofJesusChrist.org). Tell the children about how you feel when you read and ponder these events. Testify that Jesus wants us all to come unto Him and feel His love. Complete the activity page with the children.

3 NEPHI 10:4–6

Jesus protects His people as a hen protects her chicks.

The image of a hen gathering her chicks can teach the children about the comfort and protection the Savior offers if we will come unto Him.

Possible Activities

- Show a picture of a hen caring for her chicks. Read 3 Nephi 10:6, and tell the children about how a hen calls to her chicks and protects them under her wings when there is danger. Discuss how Jesus is like the hen and we are like the chicks. How can we come to Him to find safety?
- Place a picture of Jesus on a wall. Invite the children to walk around the classroom as you read 3 Nephi 10:4 out loud. Tell them to move toward the picture of Jesus when they hear the words “gathered” or “gather.” Repeat this activity as you read verses 5 and 6. Share with the children how you have come to the Savior for safety, and testify that He will protect us from spiritual dangers as we keep His commandments.

3 NEPHI 11:21–26

Jesus Christ wants me to be baptized.

The children you teach are preparing to be baptized. Christ’s teachings in these passages can help them know why baptism is important.

Possible Activities

- Read 3 Nephi 11:21–26, and invite the children to stand up every time they hear the word “baptize.” Explain that Jesus taught us the right way to be

baptized. Show a picture of a child being baptized (see *Gospel Art Book*, no. 104). If the children have seen a baptism before, invite them to describe what they saw. Who performed the baptism, and how did he do it?

- In advance, invite a father of one of the children to attend your class and share with the children why it is important that we are baptized by immersion by someone who holds the priesthood. He could also explain to the children what will happen when they are baptized and the blessings they will receive. Encourage him to use 3 Nephi 11:23–26 in his explanation.



Teach the Doctrine:
Older Children

3 NEPHI 8–11

When I am in darkness, Jesus Christ can be my light.

One powerful message of these chapters is that Jesus Christ is the light of the world, and He can be the light of our lives.

Possible Activities

- Read together 3 Nephi 8:5–7, 11–23 and 10:9–13 (if possible, darken the room as you read). Pause the reading occasionally and ask the children how it might have felt to experience these events. Read with the children some of the words Jesus Christ spoke to the people while they were in darkness (see 3 Nephi 9:13–14, 18). Why did Jesus Christ call Himself the Light of the World? What did Jesus invite the people, and us, to do so He can be our light? (see 3 Nephi 9:20–22).
- Show the children a map of the world, and help them find Jerusalem and the Americas. Explain

that the destruction described in 3 Nephi 8 was a sign to the people in the Americas that Jesus Christ had been crucified in Jerusalem. Read together 3 Nephi 11:1–15, and ask the children to tell you when they find something in these verses that helps them feel God’s love. Share verse 37, and testify that the Savior loves all children. Bear your testimony about the truth of what you are reading.



One by One, by Walter Rane

3 NEPHI 11:1–8

I can learn to recognize God’s voice in my life.

At first the people did not understand the voice they heard from heaven. What can the children learn from this account about receiving revelation?

Possible Activities

- Read 3 Nephi 11:1–4 with the children, pausing to ask questions like “Why do you think the people couldn’t understand the voice?” Then ask them to read verses 5–7 to find out what the people did

that helped them understand the voice in their hearts. How can we try to listen to God when He speaks to our hearts through the Holy Ghost?

- Play a recording of a hymn or children’s song softly so that it is difficult to hear. Ask the children if they can understand the words of the song. Then help the children search 3 Nephi 11:3 for descriptions of the voice from heaven. Why doesn’t God speak to us in a “loud” or “harsh” voice? What can we do to hear Him better?



Encourage Learning at Home

Invite the children to tell someone about Jesus’s visit to the Americas—if possible, someone who does not already know about it.

Improving Our Teaching

Address disruptions with love. “Sometimes a child acts in ways that disrupt the learning of others in the class. When this happens, be patient, loving, and understanding about the challenges the child may be facing. . . . If the child causing disruptions has special needs, talk to the ward or stake disability specialist or visit disabilities.ChurchofJesusChrist.org to find out how you can better meet those needs” (*Teaching in the Savior’s Way*, 26).

Jesus Christ invites me to come to Him (3 Nephi 8-11).

Make a paper-doll chain by cutting out the rectangle and folding it back and forth on the solid lines. Cut through all layers on the dotted lines. Cut out the figure of Jesus, and connect each end of the paper-doll chain to Jesus's hands.

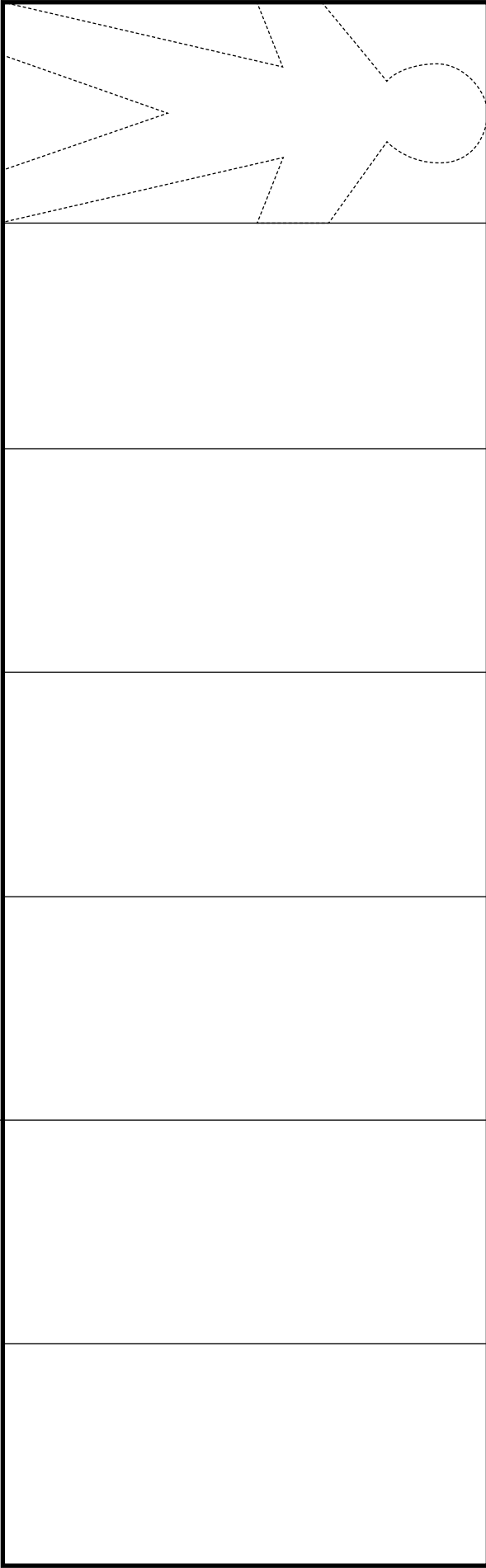
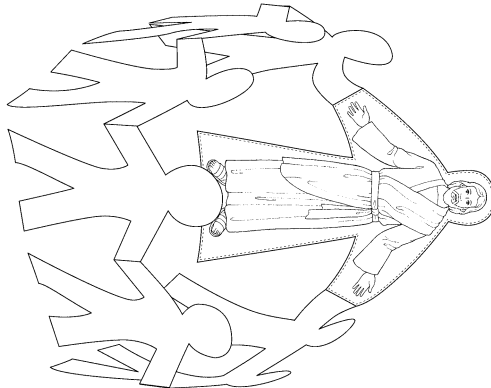
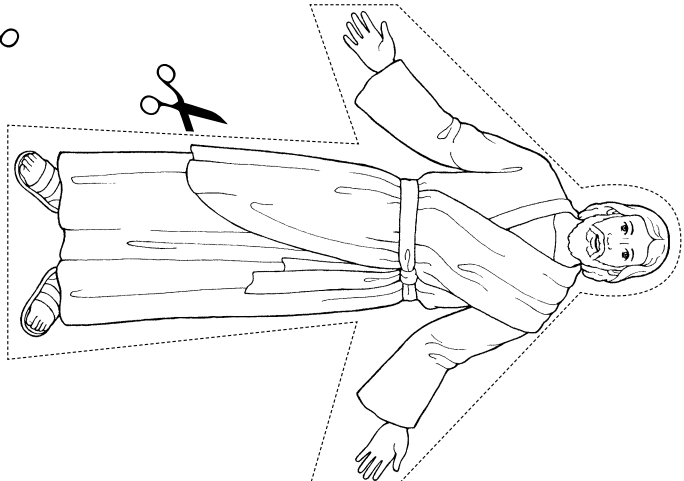



Third Nephi: These Twelve Whom I Have Chosen by Gary L. Kapp

SEPTEMBER 21-27

3 Nephi 12-16

"I AM THE LAW, AND THE LIGHT"

As you study 3 Nephi 12-16, look for truths that will be meaningful to the children you teach. This outline suggests some truths, but the Spirit may point you to others.

RECORD YOUR IMPRESSIONS _____



Invite Sharing

Pass around a picture of Jesus. Have the children take turns holding the picture and sharing one thing Jesus taught, such as something they learned at home this week.



Teach the Doctrine: Younger Children

3 NEPHI 12:14-16

I can be a good example for others.

Sometimes children might not realize how much their examples can bless others. Use these verses to encourage them to let their light shine.

Possible Activities

- Tell the children that 3 Nephi 12:14-16 is about them, and then read it aloud. Whenever you read “you” or “your,” point to the children, and ask them to point to themselves.
- Show the children a flashlight, and invite one of them to turn it on. Explain that when we follow the Savior, it’s like turning on a light that can help others follow Him too. Then cover or hide the light, and ask the children to name some things they can do to be a good example to others. Each time they do, let them uncover the light (see also this week’s activity page).
- Sing together a song that encourages the children to shine like a light, such as “Shine On” or “I Am like a Star” (*Children’s Songbook*, 144, 163). Tell the children about the light you see in them when they do “good works,” and explain how their light and examples help others and inspire you to do good works too.

3 NEPHI 14:7

Heavenly Father answers my prayers.

This verse can help the children understand that God will hear and answer their prayers.

Possible Activities

- As you read 3 Nephi 14:7, invite the children to do actions that represent each of the Savior’s invitations in this verse. For example, they could raise their hands (ask), make binoculars with their hands (seek), or make a knocking motion (knock). Help the children think of things they can say and ask for in their prayers. Explain that we can tell Heavenly Father anything, and He will listen because He loves us.
- Invite the children to show you what they do with their hands, eyes, and head when they pray. Use a song like “We Bow Our Heads” to help (*Children’s Songbook*, 25). Who are we talking to when we pray? Bear your testimony that Heavenly Father hears our prayers.

3 NEPHI 14:24–27

The Savior wants me to hear and do what He teaches.

Just hearing the Savior’s words is not enough. Only those who live His teachings can withstand life’s storms.

Possible Activities

- Sing together “The Wise Man and the Foolish Man” (*Children’s Songbook*, 281), or read 3 Nephi 14:24–27. Help the children substitute their names for “the wise man” as they sing. Why did the wise man’s house stay standing during the storm? Review verse 24 to emphasize that he both heard and did what the Savior said.

- Show the children a rock and some sand. Ask them to point to the rock when you describe a choice to follow the Savior and point to the sand when you describe a choice not to follow Him. Testify that when we do what the Savior says, we are strong like a house built on a rock.



Teach the Doctrine:
Older Children

3 NEPHI 12:6

I should hunger and thirst after righteousness.

Everyone can relate to hunger and thirst; the Savior spoke of these feelings to teach us how we should feel about seeking righteousness.

Possible Activities

- Without letting the other children hear, ask one child to pretend to eat or drink, and let the other children guess what he or she is doing. How does it feel to eat good food or drink clean water? How do we nourish our spirits? Invite the children to read 3 Nephi 12:6 to find out what the Savior wants us to “hunger and thirst after.” How do we show that we want righteousness as much as we want food and drink?
- Bring pictures of food and drink, and label each one with scripture references like Psalm 119:103; John 6:35; 2 Nephi 32:3; Enos 1:4; or 3 Nephi 20:8. Ask the children to read the passages and describe what they teach about what we can do to show that we hunger and thirst after righteousness. Share experiences in which you have

felt “filled with the Holy Ghost,” and invite the children to share their experiences.

3 NEPHI 13:1–8, 16–18

I should do good things for the right reasons.

These verses indicate that good works are not enough—our works must be inspired by love for God and a desire to serve Him.

Possible Activities

- Ask each child to search 3 Nephi 13:1–4, 5–8, or 16–18 and identify the good works mentioned in these verses (explain that doing “alms” means giving to the poor). Why did the Savior say not to be like some of the people doing these things?
- Give each child a slip of paper with a righteous act written on it (or let them think of their own examples). Ask them to think of good reasons and bad reasons for doing those things. Encourage them to always do good things for the right reasons.

3 NEPHI 14:21–27; 15:1

Spiritual safety comes from hearing and doing what the Savior teaches.

“Rain” and “floods” come to all of us in life, but we can survive trials if we both hear and do what Jesus teaches.

Possible Activities

- As a class, read 3 Nephi 14:21–27 and 15:1, and ask the children to stand up every time you read the word “doeth.” Why does the Savior

emphasize doing His sayings, not just hearing or remembering? Invite the children to draw a picture of verses 24–25, and write on the rock “Jesus” and something Jesus taught us to do. Sing together “The Wise Man and the Foolish Man” (*Children’s Songbook*, 281).

- Invite the children to stand up, and ask them to imagine that one leg represents hearing the Savior’s words and the other represents doing them. Invite them to raise the “doing” leg and balance on the “hearing” leg. What would happen if a strong wind blew through the room? Use this example to illustrate why it is safer to *do* what the Savior says and not just hear His words.



Encourage Learning at Home

Invite the children to pick one thing they learned about Jesus’s teachings today and decide how they will act on it. How will their actions help them be a light for their families and friends?

Improving Our Teaching

Adapt activities to meet needs. Don’t view these outlines as instructions you must follow. Rather, use them as a source of ideas to spark your own inspiration as you ponder the needs of the children you teach. In some cases, you might feel inspired to adapt an activity for younger children to teach to older children, or vice versa.

I can be a good example for others (3 Nephi 12:14-16).

Color and cut out the candle and the card. Fold the candle back and forth on the dotted lines, and attach it to the card. Fold the card on the dotted lines as shown, and open the card to reveal the candle inside.

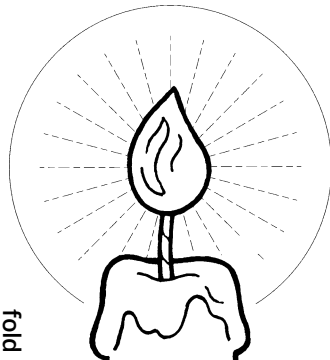

fold

fold

fold

fold

attach here

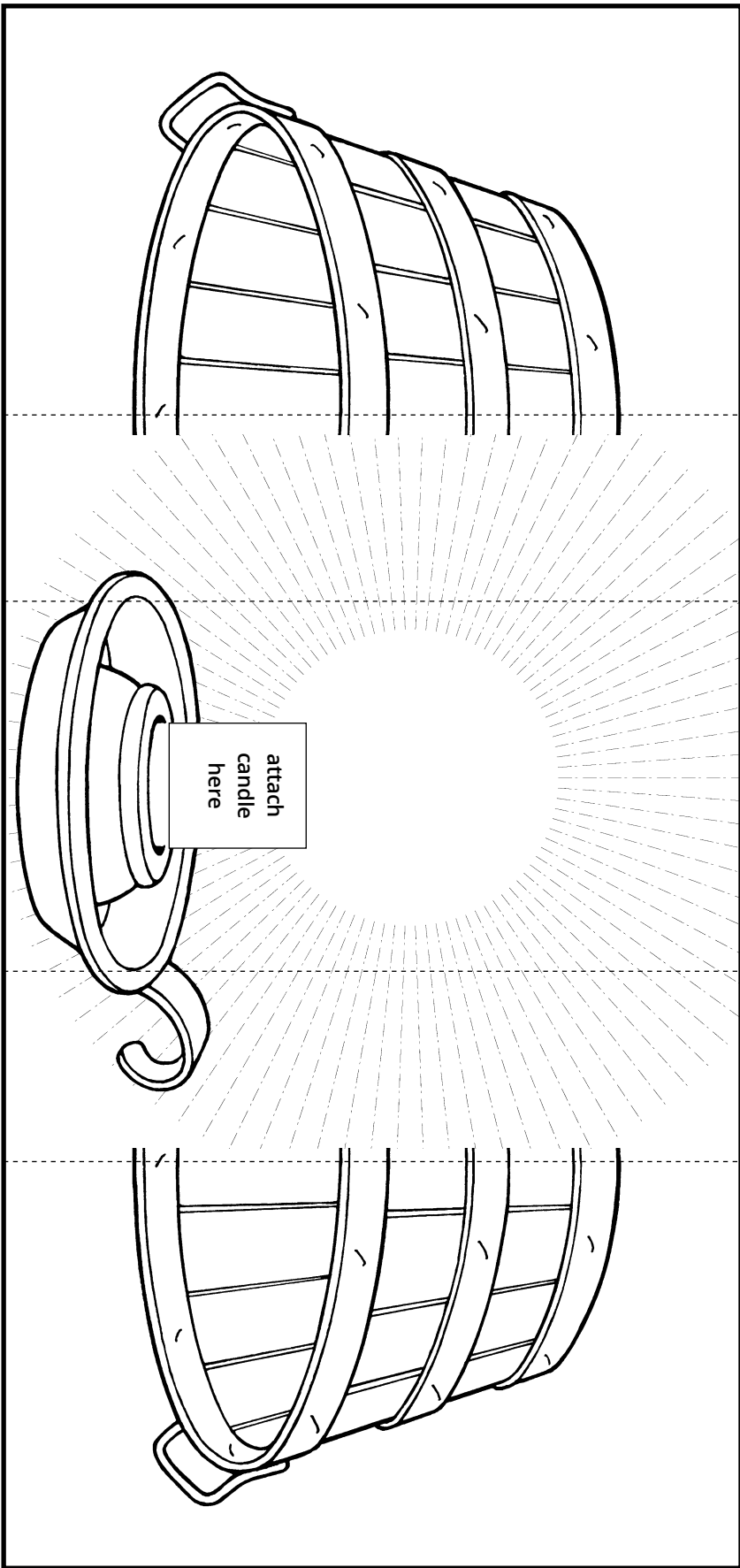



The Light of His Countenance Did Shine upon Them,
by Gary L. Kapp

SEPTEMBER 28–OCTOBER 11

3 Nephi 17–19

“BEHOLD, MY JOY IS FULL”

As you read 3 Nephi 17–19, consider what scriptures, experiences, activities, and stories would help the children understand the truths in these chapters.

RECORD YOUR IMPRESSIONS _____



Invite Sharing

Show a picture of the Savior, and invite the children to share how they might feel if He were to visit them as He did the Nephites.



Teach the Doctrine: Younger Children

3 NEPHI 17:7, 20–25

The Savior loves each of Heavenly Father’s children.

Jesus showed His love for the children when He blessed and prayed for them. How can you help the children you teach feel His love for them?

Possible Activities

- Summarize the account in 3 Nephi 17 while displaying a picture like the one in this week’s outline in *Come, Follow Me—For Individuals and Families*. Or you might use “Chapter 44: Jesus Christ Blesses the Children” (*Book of Mormon Stories*, 124–25, or the corresponding video on ChurchofJesusChrist.org). Read phrases or verses from 3 Nephi 17 that emphasize the Savior’s love for the people (such as verses 7 and 20–25). Let the children take turns holding the picture and telling what Jesus did because He loved the people.
- Use this week’s activity page to help the children draw a picture of themselves with Jesus. As they do, help them think of ways Jesus has shown His love for them.



Behold Your Little Ones, by Gary L. Kapp

3 NEPHI 18:1–12

I can think about Jesus when I take the sacrament.

There are many things that can distract a child during the sacrament. How can you help the children in your class understand the importance of thinking about the Savior and His love for them during this sacred ordinance?

Possible Activities

- Invite the children to tell you what happens during the sacrament. Read verses from the account of Jesus administering the sacrament to the Nephites (see 3 Nephi 18:1–12), and ask the children to stand up when they hear something that is similar to what we do during the sacrament. What does Jesus Christ want us to “remember” or think about during the sacrament? (see 3 Nephi 18:7, 11).
- Hum, sing, or play a hymn or Primary song while the children color pictures that can help them remember the Savior during the sacrament (see this week’s activity page). Encourage them to look at these pictures to help them remember Jesus when they partake of the sacrament.

3 NEPHI 18:15, 20–21, 24; 19:16–17, 30

Jesus teaches me how to pray.

What do you learn about prayer as you study 3 Nephi 17–19? How might you use what you learn to teach the children how to pray?

Possible Activities

- Show pictures of people praying (such as those in “Chapter 46: Jesus Christ Teaches and Prays with the Nephites” in *Book of Mormon Stories*, 128–30). Invite the children to point out details in the pictures that show that these people are praying. Read 3 Nephi 19:16–17 to explain that Jesus taught us how to pray. Let the children tell you how they feel when they pray.
- Read 3 Nephi 18:21, and invite the children to draw a picture of themselves or their families praying. Encourage the children to invite their families to pray with them.
- Sing together a song about prayer, such as “A Child’s Prayer” (*Children’s Songbook*, 12–13). Invite the children to share what they learn about prayer from the song. Share your testimony of prayer.



Teach the Doctrine: Older Children

3 NEPHI 17

The Savior loves Heavenly Father’s children.

President Ezra Taft Benson taught: “I promise you, dear children, that angels will minister unto you also. You may not see them, but they will be there to help you, and you will feel of their presence” (“To the Children of the Church,” *Ensign*, May 1989, 83).

Possible Activities

- Read together some verses from 3 Nephi 17 that you feel will be meaningful to the children you teach. As you read each verse, ask the children to choose a word or phrase that they think is important and then share why those words were meaningful to them. Testify that Jesus loves children

very much, and this is why He blessed them and prayed for them.

- Invite the children to share how they might have felt if they were among the children whom the Savior blessed. If possible, show the video “My Joy Is Full” (ChurchofJesusChrist.org) to help them imagine this event. What did the Savior do to show His love? What can we do to prepare ourselves to be with Him when He comes again?

3 NEPHI 18:1–12

As I take the sacrament, I can be filled with the Holy Ghost.

We can learn from 3 Nephi 18 how important the sacrament is to the Savior. How can you help the children feel that it is important to them?

Possible Activities

- Help the children read 3 Nephi 18:1–12. What do they learn about the sacrament from these verses? Help them read the sacrament prayers in Doctrine and Covenants 20:77 and 79 and find words and phrases in the prayers that are also found in 3 Nephi 18:1–12. What do these words and phrases mean? How can we prepare to partake of the sacrament? What do we promise, or covenant, to do when we take the sacrament?
- Sing together a song about reverence, such as “Reverently, Quietly” (*Children’s Songbook*, 26). How can reverently taking the sacrament help us feel the Spirit? How does it help us make righteous choices?

3 NEPHI 18:15–24; 19:6–9, 15–36

Praying will help me be close to Heavenly Father.

We can feel Heavenly Father near us through prayer. What messages about prayer in 3 Nephi 18–19 will help the children you teach improve their prayers?

Possible Activities

- Write the following scripture references on pieces of paper, and give them to each child or to small groups of children: 3 Nephi 18:15; 3 Nephi 18:20; 3 Nephi 18:21; 3 Nephi 19:19; and 3 Nephi 19:24. Invite the children to read the scriptures, looking for things Jesus Christ or His disciples taught about prayer. Ask them to report what they learn to the class.
- On the board, write *I thank thee for* _____. Give the children one minute to think of as many things as they can to fill in the blank. Why is it good for us to express gratitude to Heavenly Father? Then write *I ask thee for* _____ on the board, and read together 3 Nephi 18:18–21 and 19:9, 23, looking for ideas about what we should pray for.
- Share your testimony or a personal experience about the power of prayer, and encourage the children to share their testimonies or experiences.



Encourage Learning at Home

Encourage the children to talk to their parents or other family members about how they can have a more meaningful experience with the sacrament next Sunday.

Improving Our Teaching

Help young children learn from the scriptures. To help young children learn from the scriptures, focus on a single verse of scripture or even just a key phrase. You might invite the children to stand up when they hear a specific word or phrase.

I can remember the Savior (3 Nephi 18:1-12).

Cut out the two long rectangles and tape the ends together. Fold the rectangles back and forth along the dotted lines to form a book. Look at the pictures during the sacrament to help you remember the Savior.

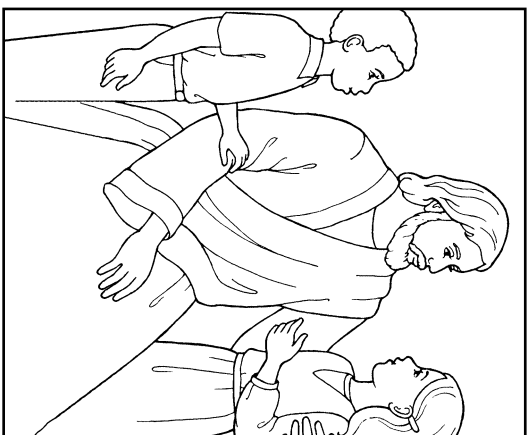
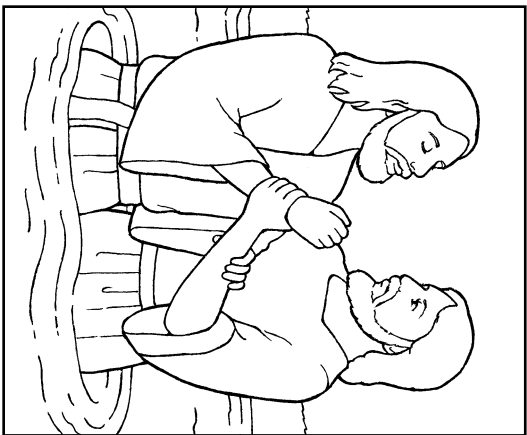
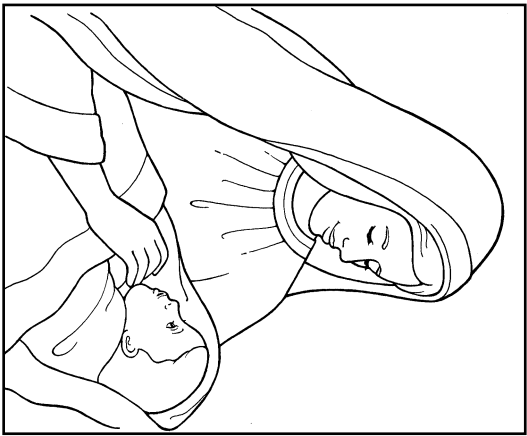
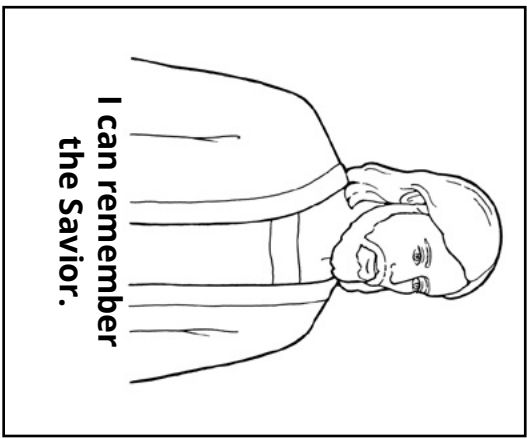
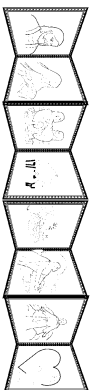

Tape here

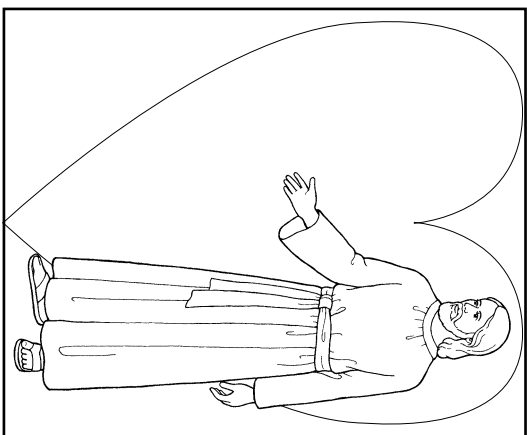
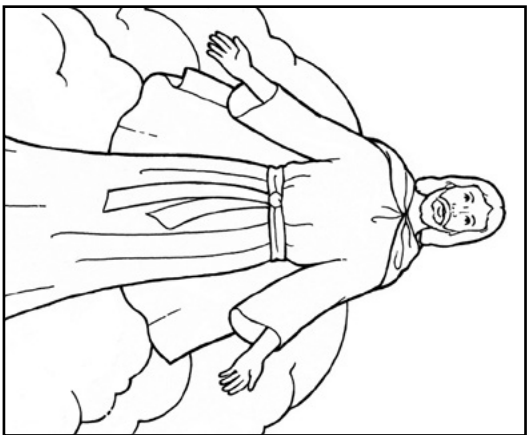
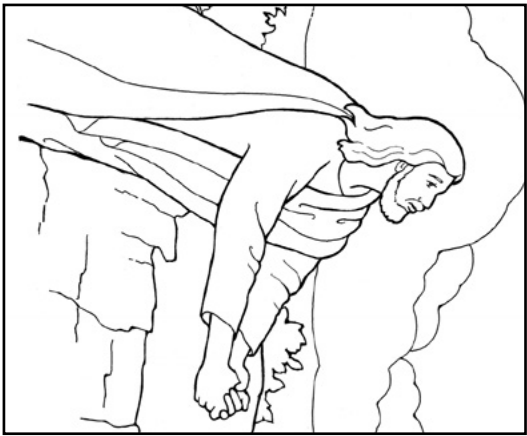

Tape here



Illustration of Christ appearing to the Nephites by Andrew Bosley

OCTOBER 12-18

3 Nephi 20–26

“YE ARE THE CHILDREN OF THE COVENANT”

As you read 3 Nephi 20–26, “search these things diligently” (3 Nephi 23:1) to find truths that you feel inspired to share with the children in your class.

RECORD YOUR IMPRESSIONS _____



Invite Sharing

Pass a picture of the Savior around the class. When each child holds the picture, invite him or her to share something that Jesus taught or did when He visited the people in the Book of Mormon. They could share something they learned at home or in Primary.



Teach the Doctrine: Younger Children

3 NEPHI 20:1

I can pray in my heart.

If your class learned about prayer last week, you could build on that lesson with one of these activities.

Possible Activities

- Ask the children to show you what they do when they pray. What do they do with their arms? their heads? their eyes? Explain that sometimes we want to talk to Heavenly Father, but we can't kneel or close our eyes. What can we do? Read to the children from 3 Nephi 20:1: “[Jesus] commanded them that they should not cease to pray in their hearts.” Tell the children how you pray in your heart.
- Draw a mouth and a heart on the board. Ask the children to point to the mouth and tell you some things they say when they pray. Then ask them to point to the heart, and explain that we can say those same things in our hearts. Testify that Heavenly Father knows our feelings and thoughts.

3 NEPHI 24:8-12

Paying tithing brings blessings.

Children who have not been baptized are not expected to pay tithing. However, it's not too early to teach them the principles and blessings associated with this law.

Possible Activities

- If your classroom has a window, invite the children to look at it. What can come into the room when the window is open? Read 3 Nephi 24:10, and explain that when we pay tithing, the “windows of heaven” open, and blessings can come into our lives.
- Show the children 10 coins (or other small objects). Invite them to count the coins with you. Testify that everything we have is a blessing from Heavenly Father. Separate one coin, and explain that when we pay tithing, we give back to Heavenly Father one-tenth of what we earn. Show pictures that represent how tithing is used to bless the Lord’s Church (such as building temples, spreading the gospel, and so on; see *Gospel Art Book*, nos. 109–10, 118–19).
- Sing together a song about tithing, like “I Want to Give the Lord My Tenth” (*Children’s Songbook*, 150). Point out phrases that teach why we pay tithing.

3 NEPHI 25:5–6

Heavenly Father wants me to learn about my ancestors.

As prophesied in these verses, Elijah has restored the sealing keys that let us be with our families for eternity.

Possible Activities

- Read 3 Nephi 25:6, and invite the children to put their hand on their heart every time they hear the word “heart.” Explain that Heavenly Father wants “the children”—all of us—to learn about and feel love for “the fathers”—our parents, grandparents, and great-grandparents.
- Invite a parent of one of the children to tell about their ancestors. Or tell the children a story about one of your ancestors; show pictures if possible. Testify that Heavenly Father wants us to be with

our families forever, and this is why He gave us temples. Sing together “Families Can Be Together Forever” (*Children’s Songbook*, 188).



Teach the Doctrine: Older Children

3 NEPHI 23:1, 5

I can search the scriptures diligently.

The Savior told the multitude to search the scriptures, and He wanted to make sure they recorded the words of the prophets (see 3 Nephi 23:1, 5–13; 26:2).

Possible Activities

- Invite the children to read 3 Nephi 23:1, 5 and look for a word that is repeated three times. What does it mean to search the words of the prophets? How is searching different from just reading? Tell the children how you search the scriptures and what you find there.
- Give each child a small card or piece of paper, and invite them to write the reference to a favorite scripture. (Give them suggestions if needed.) Let them take turns hiding their card in the room while the rest of the children cover their eyes. Ask the children to search for the scripture, and when they find it, read it together. What do we find in this scripture that is important to us?

3 NEPHI 24:8–12

Paying tithing opens the windows of heaven.

When you teach children about tithing, you prepare them to receive “a blessing that there shall not be room enough to receive it” (3 Nephi 24:10).

Possible Activities

- Write on the board *If I pay tithing, the Lord will _____*. Invite the children to read 3 Nephi 24:8–12, and help them find phrases to complete this sentence. Share an experience in which you were blessed because you paid tithing.
- Write a few money amounts on the board, and help the children calculate how much tithing (10 percent) we should give for each amount. Show them how to fill out a tithing donation slip.
- Help the children list on the board some of the ways tithing is used to bless the Lord's Church (to build temples, spread the gospel, publish the scriptures, and so on). Ask the children to draw pictures (or find pictures in Church magazines) of ways tithing blesses the Church.

3 NEPHI 25:5–6

Heavenly Father wants me to learn about my ancestors.

Consider how you will inspire the children to search out their ancestors so that when they are old enough to go to the temple, they can perform ordinances on behalf of those ancestors.

Possible Activities

- Tell the children that 3 Nephi 25:5–6 contains a prophecy about an event that would happen in the latter days. Invite them to read these verses to find out what it was. Testify that this prophecy has been fulfilled, and invite the children to read about it in Doctrine and Covenants 110:13–16

(see also *Gospel Art Book*, no. 95). Explain that when we learn about our ancestors and do temple work for them, our hearts are turning to our fathers.

- Tell the children about one of your ancestors who died without the opportunity to be baptized. Show a picture if possible. Bear your testimony that Heavenly Father loves this person, so He prepared a way for him or her to receive baptism through the work done in temples. Ask the children to find a phrase in 3 Nephi 25:6 that might describe how you feel about your ancestor.
- Help the children fill out a family tree with names of their parents and grandparents. Encourage them to ask their parents to help them add more names.



Encourage Learning at Home

Invite the children to ask their parents or grandparents to tell them stories about their ancestors.

Improving Our Teaching

Children learn in many ways. Children enjoy learning through new and varied experiences. Use activities that allow them to move about, use all their senses, and try new things. (See *Teaching in the Savior's Way*, 25.)

Paying tithing helps build God's kingdom (3 Nephi 24:8-12).

Color the pictures, then cut out the circle and the spinner. Attach the spinner to the center of the circle, and rotate it to see some ways your tithing helps the Lord's work.

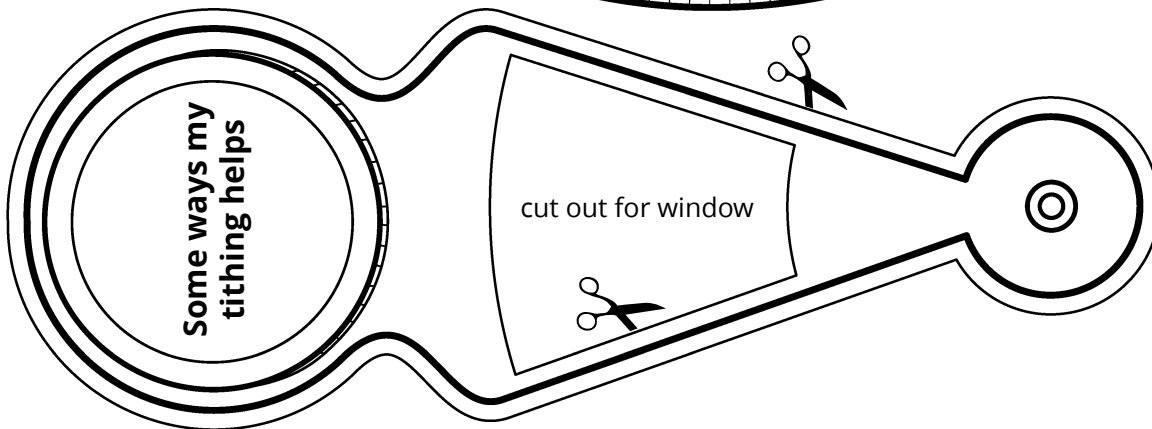
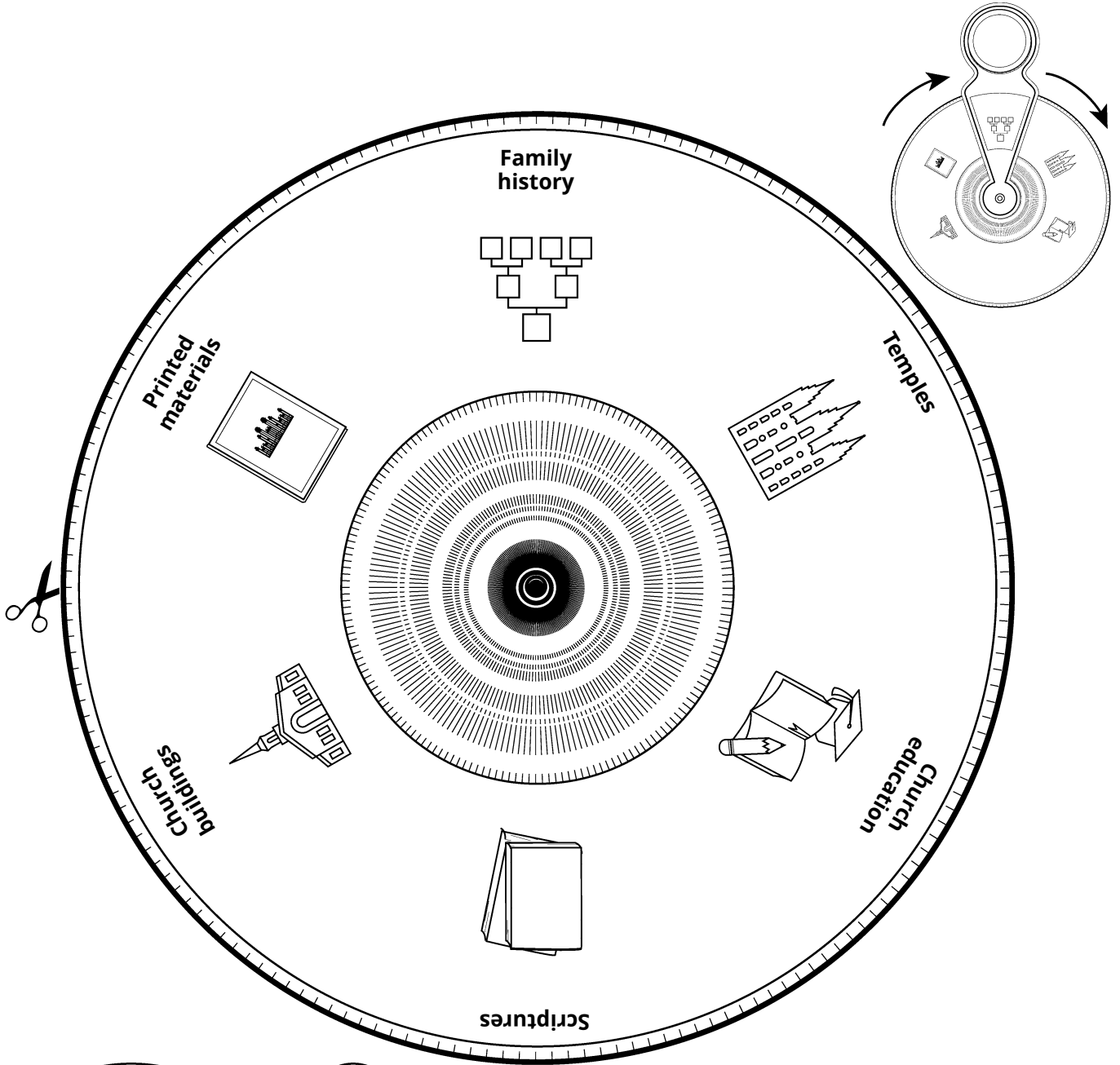



Christ's Prayer, by Derek Hegsted

OCTOBER 19-25

3 Nephi 27-4 Nephi

"THERE COULD NOT BE A HAPPIER PEOPLE"

As you read 3 Nephi 27-4 Nephi, consider experiences, thoughts, scriptures, and stories that would help the children understand the concepts in these chapters.

RECORD YOUR IMPRESSIONS _____



Invite Sharing

Help the children recall what they've learned over the past few weeks about what Jesus taught the people in the land of Bountiful. Explain that the Book of Mormon tells us how the people were blessed when they obeyed what Jesus taught them.



Teach the Doctrine: Younger Children

3 NEPHI 27:1-22

I belong to the Church of Jesus Christ.

How can the Savior's words to His disciples help the children understand the importance of belonging to the Church of Jesus Christ?

Possible Activities

- Ask each child to say his or her name. Why are our names important? Tell them that Jesus's disciples wanted to know what they should name Christ's Church. Read to them the Savior's response in 3 Nephi 27:7. Who did Jesus say His Church should be named after?
- Make a badge that says "I belong to The Church of Jesus Christ of Latter-day Saints" for each child to wear home. Let the children color their badges. Sing "The Church of Jesus Christ" (*Children's Songbook*, 77) as a class. Tell why you are thankful to belong to the Church, and ask the children why they are thankful for the Church.
- Help the children put together the puzzle on this week's activity page. Explain that Jesus wants His Church to be built on His gospel, and use the activity page to talk to the children about what that means.

4 NEPHI 1:2–3, 15–17**Living the gospel brings me joy.**

The happiness of the people described in 4 Nephi can help the children learn about the joy that comes from living the gospel.

Possible Activities

- Invite the children to talk about what makes them happy. To tell the children about the happiness of the people in 4 Nephi, read key phrases from verses 2–3 and 15–17. You could also refer to “Chapter 48: Peace in America” (*Book of Mormon Stories*, 136–37, or the corresponding video on ChurchofJesusChrist.org). Emphasize that the people were happy because they were converted to the Lord, they lived the commandments, and they loved one another.
- Show pictures of happy people. Explain that the people in 4 Nephi had almost 200 years of happiness because they all tried their best to live the gospel. Help the children think of some commandments they could obey. For example, you could read them 4 Nephi 1:15 to teach that the people didn’t fight with each other anymore. Invite the children to act out obeying the commandments they thought of. Sing together a song about the joy that comes from living the gospel, such as “When We’re Helping” (*Children’s Songbook*, 198).
- Read phrases from 4 Nephi 1:24–29, 34–35, and 43 that describe what happened when some of the Nephites stopped keeping the commandments. As you do, invite the children to make a sad face when they hear something that sounds unhappy. Testify that keeping the commandments leads to happiness.

**Teach the Doctrine:
Older Children****3 NEPHI 27:3–8****I belong to the Church of Jesus Christ.**

Consider how you will help the children you teach recognize the great blessings that come from being a member of the Church of Jesus Christ.

Possible Activities

- Help the children read 3 Nephi 27:3, looking for the question Jesus’s disciples asked Him. Then invite them to look in 3 Nephi 27:5–8 for the answer. According to these verses, why is the name of the Church important?
- Help the children think of different groups they belong to, such as a family or a Primary class. Ask them to tell you what they like about belonging to each group. Ask the children to help you write each word of the name of the Church on a separate piece of paper. Then mix the papers up, and invite the children to arrange these words in order. What blessings have we received because we are members of The Church of Jesus Christ of Latter-day Saints?

3 NEPHI 27:13–22**The Church of Jesus Christ is built upon
His gospel.**

The Savior summarized His gospel in 3 Nephi 27. How might His words help the children understand what the gospel is?

Possible Activities

- Explain to the children that the word *gospel* means “good news” (see Bible Dictionary, “Gospels”). Help the children search 3 Nephi 27:13–15 for something that sounds like good news to them. Why are we grateful to know the gospel of Jesus Christ?
- Write on the board principles of the gospel like *faith, repentance, baptism, the Holy Ghost, and enduring to the end*. Invite the children to search 3 Nephi 27:19–21, looking for these words or similar words in Jesus’s description of His gospel.
- Ask the children to imagine they have a friend who asks them what they believe as a member of the Church. Help them find truths in 3 Nephi 27:13–21 that they could share to summarize what we believe.
- Invite the children to choose one of the gospel truths the Savior taught in 3 Nephi 27:13–21 that they want to learn more about. Help them use the footnotes, Topical Guide, or Guide to the Scriptures to find a scripture or two related to that truth. Invite them to share their scriptures with each other and what they learned. Why are we grateful to know the gospel of Jesus Christ?

4 NEPHI

Living the gospel brings me joy.

Because they were converted to Jesus Christ and His gospel, the people described in 4 Nephi were able to establish a society of peace and unity. What can the children learn from them?

Possible Activities

- Prepare strips of paper with phrases from 4 Nephi 1:2–3, 5, and 15–17 that describe the blessings the people received (such as “there was no contention in the land”). Put the papers in a container, and let each child pick one and read it. Encourage the

children to find their phrase in these verses from 4 Nephi. What do we learn from these phrases? What similarities do we see between these verses and the definition of Zion in Moses 7:18?

- To help the children practice what is taught in 4 Nephi 1:15–16, present them with situations where people are angry with each other. Invite them to role-play what the situation might be like if they tried to live with “no contention.” Why is it easier to avoid contention when we have the “love of God” in our hearts?
- Read with the children the following verses, and ask them to find reasons the Nephites and Lamanites no longer had peace and happiness: 4 Nephi 1:20, 24–29, 34–35, and 43. How can we avoid these dangers? Help the children discover ways we can avoid becoming prideful by reviewing *Teachings of Presidents of the Church: Ezra Taft Benson* (2014), 238–39.



Encourage Learning at Home

Encourage the children to decide on one thing they will do to bring more peace and happiness to their home and share it with their families.

Improving Our Teaching

Support the children’s parents. “Parents are the most important gospel teachers for their children—they have both the main responsibility and the greatest power to influence their children (see Deuteronomy 6:6–7). As you teach children at church, prayerfully seek ways to support their parents in their essential role” (*Teaching in the Savior’s Way*, 25).

I belong to the Church of Jesus Christ (3 Nephi 27:13-21).

Cut out the puzzle pieces of the church on the dotted lines. Put the pieces back together to see how the Church of Jesus Christ helps us have faith in Jesus Christ, repent, be baptized and confirmed, and live faithfully to the end.

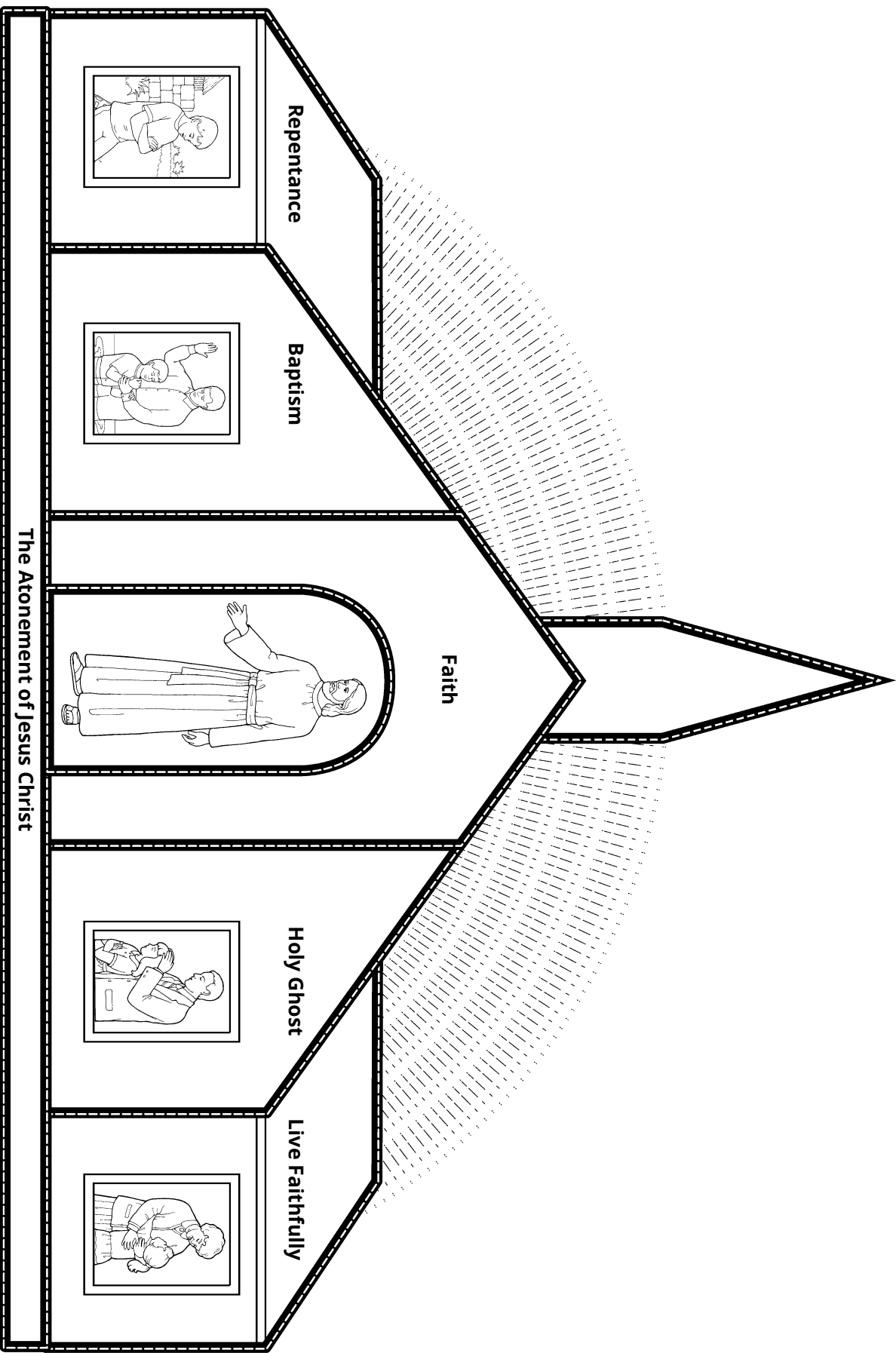



Mormon Abrogating the Plates, by Tom Lovell

OCTOBER 26–NOVEMBER 1

Mormon 1–6

“I WOULD THAT I COULD PERSUADE ALL . . . TO REPENT”

The events described in Mormon 1–6 might be difficult for the children to fully understand, but they can still learn lessons from Mormon’s account of living righteously in a wicked world. How can you use his experience to teach the children how to stay true to the gospel?

RECORD YOUR IMPRESSIONS _____



Invite Sharing

What do the children know about Mormon? Invite them to share what they know or learned with their families. Showing a picture of Mormon like the one in this week’s outline in *Come, Follow Me—For Individuals and Families* could help.



Teach the Doctrine: Younger Children

MORMON 1:1–3

I can be righteous like Mormon.

Though the children you teach are young, they can develop spiritual qualities and live righteously.

Possible Activities

- Read Mormon 1:1–3 to the children, or use “Chapter 49: Mormon and His Teachings” (*Book of Mormon Stories*, 138–42, or the corresponding video on ChurchofJesusChrist.org). Invite them to listen for how old Mormon was when Ammaron gave him a special mission. Then ask them to hold up that many fingers. To help the children imagine how young Mormon was, show them a picture of someone who is 10 years old. Help them understand the qualities that Ammaron saw in Mormon when he was young, and testify that the children can be like Mormon as they follow Jesus Christ.
- Play a game in which the children repeat basic actions that you do. Then show pictures of things Jesus did, and talk about how we can follow Him (see *Gospel Art Book*, nos. 33–35, 41–42). Discuss ways Mormon followed Jesus Christ—for example, by teaching the gospel, encouraging people to obey God, and loving others.

MORMON 3:3, 9**Heavenly Father gives me many blessings.**

Mormon’s teachings can help the children recognize the blessings Heavenly Father has given them.

Possible Activities

- Read Mormon 3:3 and 9 to the children, and explain that the Nephites had not recognized that Heavenly Father had blessed them. Help the children think of blessings Heavenly Father has given them. Show pictures or objects to give them ideas. What can we do today to show we are thankful to Heavenly Father for our blessings?
- Help the children think of blessings Heavenly Father has given them, and ask them to draw pictures of some of these blessings. Invite them to hang their pictures somewhere at home where they can see them and remember that Heavenly Father blesses them in many ways. You could also invite them to identify blessings that come from Heavenly Father as they sing the first verse of “I Thank Thee, Dear Father” (*Children’s Songbook*, 7).

MORMON 3:12**Heavenly Father wants me to love everyone.**

How can you help the children you teach have a desire to feel love for those around them?

Possible Activities

- Ask each child to draw a person on the board, and point out how each person they drew looks different from the others. Draw a large heart surrounding all the drawings. Help the children understand that Heavenly Father wants us to love all people. Read Mormon 3:12, emphasizing the

words “love” and “loved.” What did Mormon do to show his love for others?

- Sing a song together about loving others, such as “Jesus Said Love Everyone” (*Children’s Songbook*, 61), while showing pictures of children from around the world. Testify of God’s love for all of His children. Complete this week’s activity page with the children.

**Teach the Doctrine:
Older Children****MORMON 1:1-3; 2:1, 23-24; 3:1-3, 12, 17-22****I can be righteous like Mormon.**

Mormon was very young when Ammaron recognized that he would be responsible enough to take care of the sacred records. What righteous qualities do you see in the children you teach?

Possible Activities

- Invite each of the children to read one of the following passages, and help them share what they learn about Mormon: Mormon 1:1–3; 2:1, 23–24; and 3:1–3, 12, 20–22. Then share righteous qualities you see in each of the children.
- Show a picture of Mormon (see the picture in this week’s outline in *Come, Follow Me—For Individuals and Families*). Help the children see that because Mormon was responsible and trustworthy enough to keep and preserve the Nephite records, we have the Book of Mormon today. Talk with the children about what it means to be responsible and trustworthy. Invite them to ponder ways they can be more responsible.



Mormon, Age 10, by Scott M. Snow

MORMON 2:8–15; 5:10–11

Godly sorrow leads to real change.

Mormon saw that the wicked Nephites were sorrowful, but their sorrow was not the kind that would inspire them to repent (see Mormon 2:13). How can you help the children understand the difference between worldly sorrow and the godly sorrow that leads to repentance?

Possible Activities

- Write the following headings on the board: *Sorrow that leads to repentance* and *Sorrow that doesn't lead to repentance*. Invite the children to take turns reading verses from Mormon 2:8, 10–15. Help them write things they learn about sorrow under the appropriate headings on the board. How can we make sure that the sorrow we feel for our sins leads us to change?
- Invite a member of the bishopric or a parent of one of the children to share with the class how godly sorrow can help us change to be more like Heavenly Father and Jesus Christ. Why is it important to recognize whether we are feeling godly sorrow or worldly sorrow? Invite the children to search Mormon 2:12 to find reasons why repentance should make our “heart[s] . . . rejoice” (Mormon 2:12).

MORMON 3:12

I can feel Heavenly Father's love for others.

It's often easy to love those who love us and are like us, but Mormon demonstrated that with help from Heavenly Father, we can love those who believe and act differently than we do.

Possible Activities

- Help a child read Mormon 3:12, and invite the children to write one sentence that summarizes what they learn from Mormon about loving others. Invite the children to share what they wrote. How can we feel the love that God has for others? (see Moroni 7:48). What can we do to show our love for people in our class and in our families?
- Invite the children to complete this week's activity page. Help them think of meaningful ways to reach out in love to those who might be different from us.



Encourage Learning at Home

Encourage the children to display this week's activity page somewhere at home so that they will be reminded to show love for others. Give them an opportunity in a future class to share what they did.

Improving Our Teaching

Modify activities to fit the ages of the children you teach. Younger children need detailed explanations and learn from simpler teaching methods. As they mature, they can contribute more and may be better at sharing their thoughts. Give all children age-appropriate opportunities to share, testify, and participate, and be sure to provide help as needed. (See *Teaching in the Savior's Way*, 25–26.)

Heavenly Father wants me to love everyone (Mormon 3:12).

Mormon loved his people even though they were wicked. Color the picture of Mormon, and write on the line one way you can show love for others, including those who are different from you.

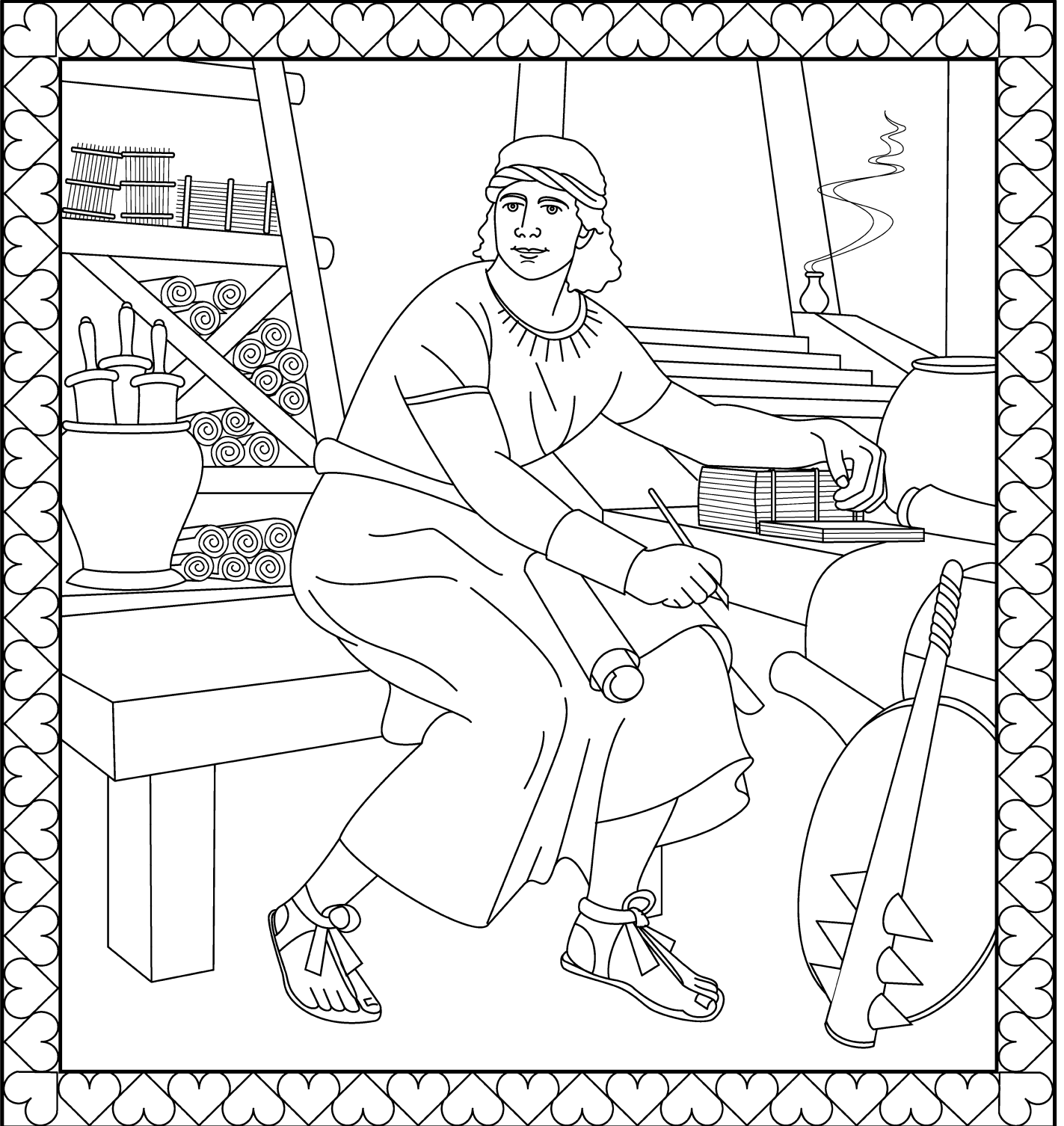



Mormon Writing on Gold Plates, by Dale Kilborn

NOVEMBER 2-8

Mormon 7-9

“I SPEAK UNTO YOU AS IF YE WERE PRESENT”

As you read Mormon 7-9, consider what you most desire the children you teach to know. Make plans to teach the truths you feel will bless their lives.

RECORD YOUR IMPRESSIONS _____



Invite Sharing

Pass around a copy of the Book of Mormon. Invite the children, when it is their turn to hold the book, to share one thing they have learned from it. If they need help, remind them of things they have learned recently in class.



Teach the Doctrine: Younger Children

MORMON 7:8-10

The Book of Mormon and the Bible both testify of Jesus Christ.

Mormon taught that the Book of Mormon was written to help us believe the Bible and that those who believe the Bible will believe the Book of Mormon.

Possible Activities

- Show the children the title page of the Book of Mormon, and point to the words of the title as you read it, emphasizing the word *another*. Help the children think of other books of scripture that teach us about Jesus. Show them that the Bible has the Old Testament and the New Testament. Help the children say “Old Testament, New Testament” when you point to the Bible and “Another Testament” when you point to the Book of Mormon.
- Display a world map or the activity page for this outline, along with a Bible and Book of Mormon. Use these items to teach the children that the Bible is a record of Jesus’s teachings in and around Jerusalem and the Book of Mormon is a record of His teachings in the Americas.
- Choose several events and truths that both the Bible and the Book of Mormon testify of, such as Jesus’s birth, death, and Resurrection. Show pictures from the *Gospel Art Book* that depict these events and truths. Ask the children to describe what they see in the pictures, and tell them that both the Bible and the Book of Mormon teach about these things.

MORMON 8:3**I can choose the right even when I feel alone.**

Moroni was the last righteous Nephite, but he stayed true to his testimony. Help the children learn from his example.

Possible Activities

- Read Mormon 8:3, emphasizing that Moroni was all alone, but he still kept the commandments, including the commandment to finish the Book of Mormon. Share a time when you were faithful even when you felt alone.
- After discussing Moroni’s example, share some scenarios in which a child must decide whether or not to choose the right, even though no one is looking. What would Moroni have done?
- Sing with the children a song about choosing the right, such as “Stand for the Right” (*Children’s Songbook*, 159). Why is it important to choose the right all the time, even when you are alone?

MORMON 9:7–21**God is “a God of miracles.”**

Help the children understand that miracles are important in God’s work and that God will work miracles when His people have faith.

Possible Activities

- Explain that a miracle is something God does to show His power and bless our lives (see Bible Dictionary, “Miracles”). Read words and phrases from Mormon 9:11–13, 17 that describe some of God’s miracles. Help the children think of other miracles found in the scriptures (pictures from the *Gospel Art Book*, such as nos. 26, 40, 41, and 83, can help). Testify that God worked miracles in ancient times and He still works miracles today.

- Share an experience when you have seen miracles in the Church today or in your own life. Bear your testimony that God is “a God of miracles” (Mormon 9:11).

**Teach the Doctrine:
Older Children****MORMON 7:8–10****The Book of Mormon and the Bible both testify of Jesus Christ.**

Mormon taught that the “gospel of Christ . . . shall be set before [us]” in both the Bible and the Book of Mormon. Consider how you will teach the children that both sacred books are important to us.

Possible Activities

- Write Mormon 7:9 on the board, but leave blanks in place of the words *this* and *that*. Also write on the board *this = the Book of Mormon* and *that = the Bible*. Invite the children to read Mormon 7:9 out loud and use the phrases on the board to fill in the blanks. What do we learn about the Bible and the Book of Mormon from this verse?
- Display a Book of Mormon and a Bible. Share a few stories from each book, showing pictures if available (see the *Gospel Art Book*). Invite the children to point to the book the story comes from. Why do we need both books?
- Write each word of the eighth article of faith on separate pieces of paper. Give one or two words to each child, and invite the children to work together to put the words in the correct order. Then ask them to repeat the article of faith several times. What does it teach us?



The Book of Mormon testifies of Jesus Christ.

MORMON 8:1-7

I can choose the right even when I feel alone.

Moroni's determination to "fulfil the commandment of [his] father," even though his father had died, can inspire the children to obey God's commandments.

Possible Activities

- Read Mormon 8:1-7 with the children, and invite them to share how they would have felt if they had been Moroni. Ask them to look again at verses 1, 3, and 4 to find what Moroni was commanded to do. How did Moroni "fulfil the commandment of [his] father"? How can we be more like Moroni?
- Invite the children to each write down a situation in which they have to make a choice between right or wrong when no one is watching. Put their ideas in a container, and let the children take turns picking a situation and sharing what they would do to be like Moroni.

MORMON 8:24-26; 9:7-26

God is "a God of miracles."

There are many people today who don't believe that miracles still happen. Use Moroni's teachings in

these verses to teach the children that when we have faith, we can see God work miracles in our lives.

Possible Activities

- Show the children a recipe. What would happen if you left out an essential ingredient? Invite the children to search Mormon 8:24 and 9:20-21 to find the necessary "ingredient" that we must have before God can work miracles. Share examples of miracles—big or small—that you have seen in the Church or in your life. Invite the children to share their own examples.
- Divide the children into two teams. Invite each team to look for examples of miracles in some or all of these scriptures: Mormon 8:24; 9:11-13, 16-18, 21-25. What could we say to someone who thinks miracles don't happen anymore? (see Mormon 9:9, 15-21).



Encourage Learning at Home

Invite the children to ask a family member to describe a miracle that strengthened his or her testimony.

Improving Our Teaching

Children can recognize the influence of the Spirit. Teach the children that the feelings of peace, love, and warmth they have when they talk or sing of Jesus Christ and His gospel come from the Holy Ghost (see *Teaching in the Savior's Way*, 11).

The Book of Mormon and the Bible both testify of Jesus Christ (Mormon 7:8-10).

The Book of Mormon and the Bible were written by prophets in different parts of the world, but both books teach about Jesus Christ.

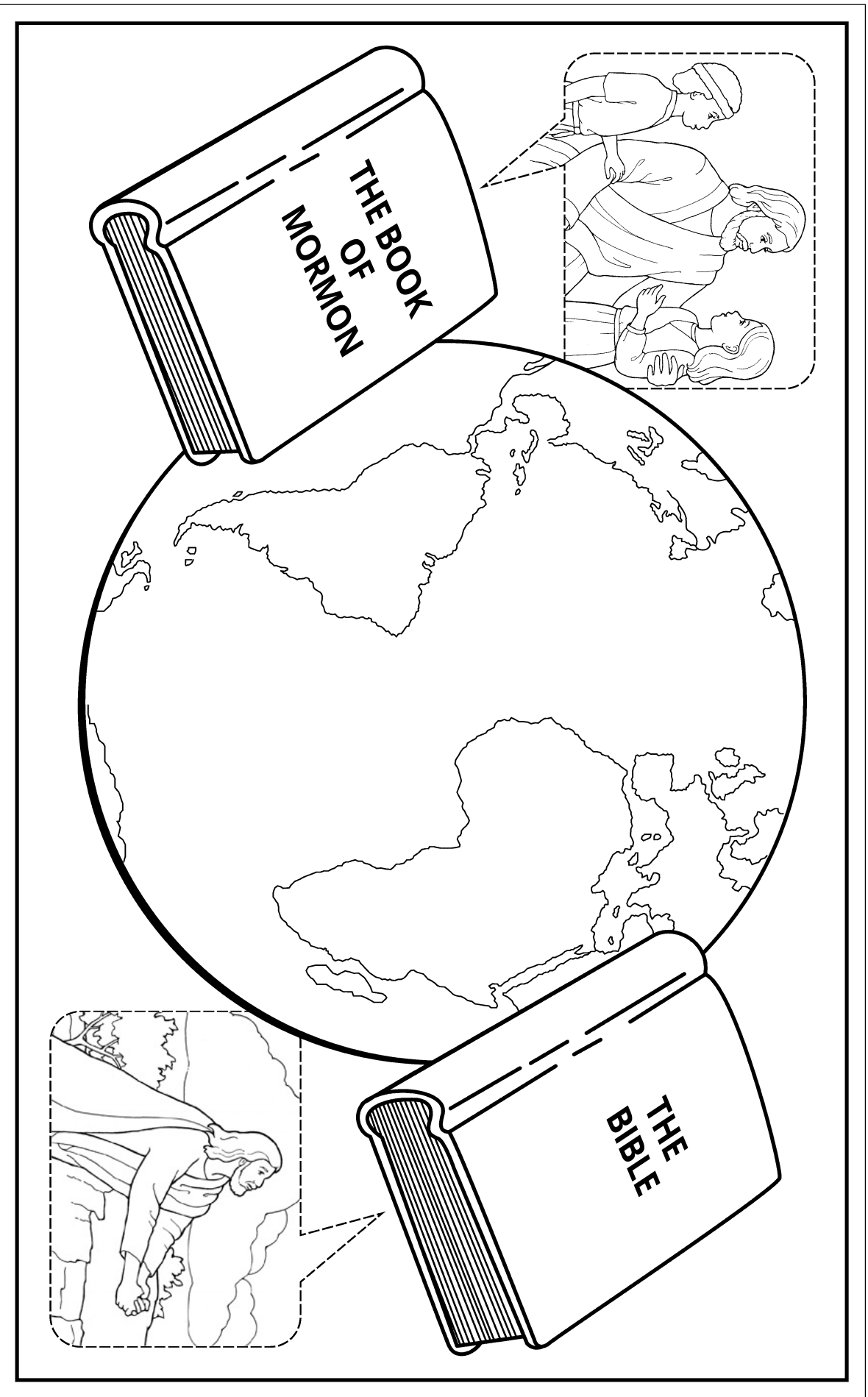



The Jaredites Leaving Babel, by Albin Veselka

NOVEMBER 9–15

Ether 1–5

“REND THAT VEIL OF UNBELIEF”

As you review what you learned during your study of Ether 1–5, what truths do you feel impressed to help the children discover? Perhaps there are ideas in this outline that can help.

RECORD YOUR IMPRESSIONS _____



Invite Sharing

Show a picture of the brother of Jared (see this week’s outline in *Come, Follow Me—For Individuals and Families*). Invite the children to share what they know about him.



Teach the Doctrine: Younger Children

ETHER 1:33–43; 2:16–25; 3:1–6

Heavenly Father hears and answers my prayers.

The story of the brother of Jared illustrates several ways in which God can help us when we pray.

Possible Activities

- Invite a few ward members who know another language to say a few sentences in that language for your class (or play a recording of another language). Let the children pretend to speak another language, and point out how hard it is to understand one another when we don’t speak the same language. Use this to introduce the account of the Tower of Babel in Genesis 11:1–9 and Ether 1:33. Explain how the brother of Jared prayed that he and his friends and family would be able to understand one another (see Ether 1:34–37). Read and help the children understand the Lord’s response to his prayer in Ether 1:35. You could also use “Chapter 50: The Jaredites Leave Babel” (*Book of Mormon Stories*, 143–44, or the corresponding video on ChurchofJesusChrist.org).
- Invite the children to pretend to build a barge, as described in Ether 2:16–17. Explain the problems the Jaredites had with their barges (see Ether 2:19), and ask the children what they would do about these problems. Read Ether 2:18–19 to teach the children how the brother of Jared took his

problems to the Lord in prayer. Testify that we can always pray when we have questions or problems.

- Briefly summarize Ether 2:19–3:6 to explain how the Lord responded to the brother of Jared’s questions about the barges. Place 16 stones throughout the classroom, and invite the children to count them as they find them. Show the picture in this week’s outline in *Come, Follow Me—For Individuals and Families*, and let the children retell the story (see also this week’s activity page).

ETHER 3:13, 15

I was created in the image of God.

When the brother of Jared saw the Lord, he learned that “all men were created in the beginning after [His] own image” (Ether 3:15).

Possible Activities

- Show a picture of the Savior, and invite the children to point to various parts of His body. Read Ether 3:13 and 15, and explain that when the brother of Jared saw Jesus Christ, he learned that we all look like Jesus. As you point to a body part in the picture, invite them to point to the same part of their own bodies. Testify that we were created to look like our Heavenly Father and Jesus Christ.
- Sing together a song related to our bodies, such as “Head, Shoulders, Knees, and Toes” (*Children’s Songbook*, 275). Help the children talk about why they are grateful for different parts of their bodies.



We are created in God’s image.



Teach the Doctrine: Older Children

ETHER 1:33–43; 2; 3:1–17

I can receive revelation to help me.

How can you help the children learn about revelation from the brother of Jared’s example? What experiences can you share when the Lord helped you find solutions to your problems or questions?

Possible Activities

- Before class, write the phrase “Stand up, turn around, and sit down” in different languages on several slips of paper (you could use an online translator or the help of someone who knows another language). Give one slip to each of the children, and invite them to try to follow the instructions. Use this to help explain what motivated the brother of Jared’s prayers in Ether 1:33–37. Read these verses together, and ask the children to pay attention to how the Lord felt toward Jared and his friends and family. What do we learn from this account about prayer?
- Assign each child to read one of the following passages, and help them look for a question or problem the brother of Jared had: Ether 1:33–35; Ether 1:36–37; and Ether 2:18–20. What did the brother of Jared do about these problems or questions? How did the Lord help him in each case? Invite the children to think about problems they need help with. How can they follow the example of the brother of Jared to find solutions to their problems? Share an experience in which you prayed for help and the Lord helped you.

ETHER 3:4-17**I was created in the image of God.**

The children you teach will encounter many false messages about God, themselves, and their physical bodies. These verses are an opportunity to teach eternal truths about these topics.

Possible Activities

- Read with the children Ether 3:6–16, and help them make a list of things the brother of Jared learned about the Lord from this experience. Why is it important to know these things? For example, how does it affect the way we view our bodies to know that we are created in the Lord’s image?
- Write *physical body* and *spiritual body* on the board. Invite the children to share characteristics of a physical body (we have skin, blood, and so on), and write their answers on the board. Read Ether 3:4–17 together, and invite the children to look for what they learn about our spiritual bodies. Testify that our bodies and spirits were “created after [Jesus’s] own image” (Ether 3:15).

ETHER 5:2-4**Three witnesses testify of the Book of Mormon.**

Moroni prophesied that the Three Witnesses would help establish the truth of the Book of Mormon. You can use this prophecy to strengthen the children’s testimonies and inspire them to be witnesses of the Book of Mormon in their own way.

Possible Activities

- Write on the board some important words from Ether 5:2–4, such as *plates*, *power*, *true*, *witnesses*, and *testimony*. Read these verses with the children, and invite them to stop when you get to one of the words on the board and talk about why these words are important. To teach the children about the Three Witnesses, you might refer to “Chapter 7: Witnesses See the Gold Plates” (*Doctrine and Covenants Stories*, 31–33) and “The Testimony of Three Witnesses” in the Book of Mormon. Why did God want three people to see the golden plates?
- Tell the children how you know the Book of Mormon is true. Invite the children to share why they know it is true. Help them think of ways that they can be witnesses of the Book of Mormon, and encourage them to share their witness with someone this week.

**Encourage Learning at Home**

Invite the children to think of something they could ask for Heavenly Father’s help with, as the brother of Jared did. Encourage them to seek His help through prayer.

Improving Our Teaching

Teach during activities. As the children are doing activities such as drawing or working on an activity page, you can use the time to emphasize the truths being taught through those activities.

Heavenly Father hears and answers my prayers (Ether 1:33-43; 2:16-25; 3:1-6).

The brother of Jared brought 16 stones for the Lord to touch so the people would have light in their barges. Help the brother of Jared find 16 hidden stones.

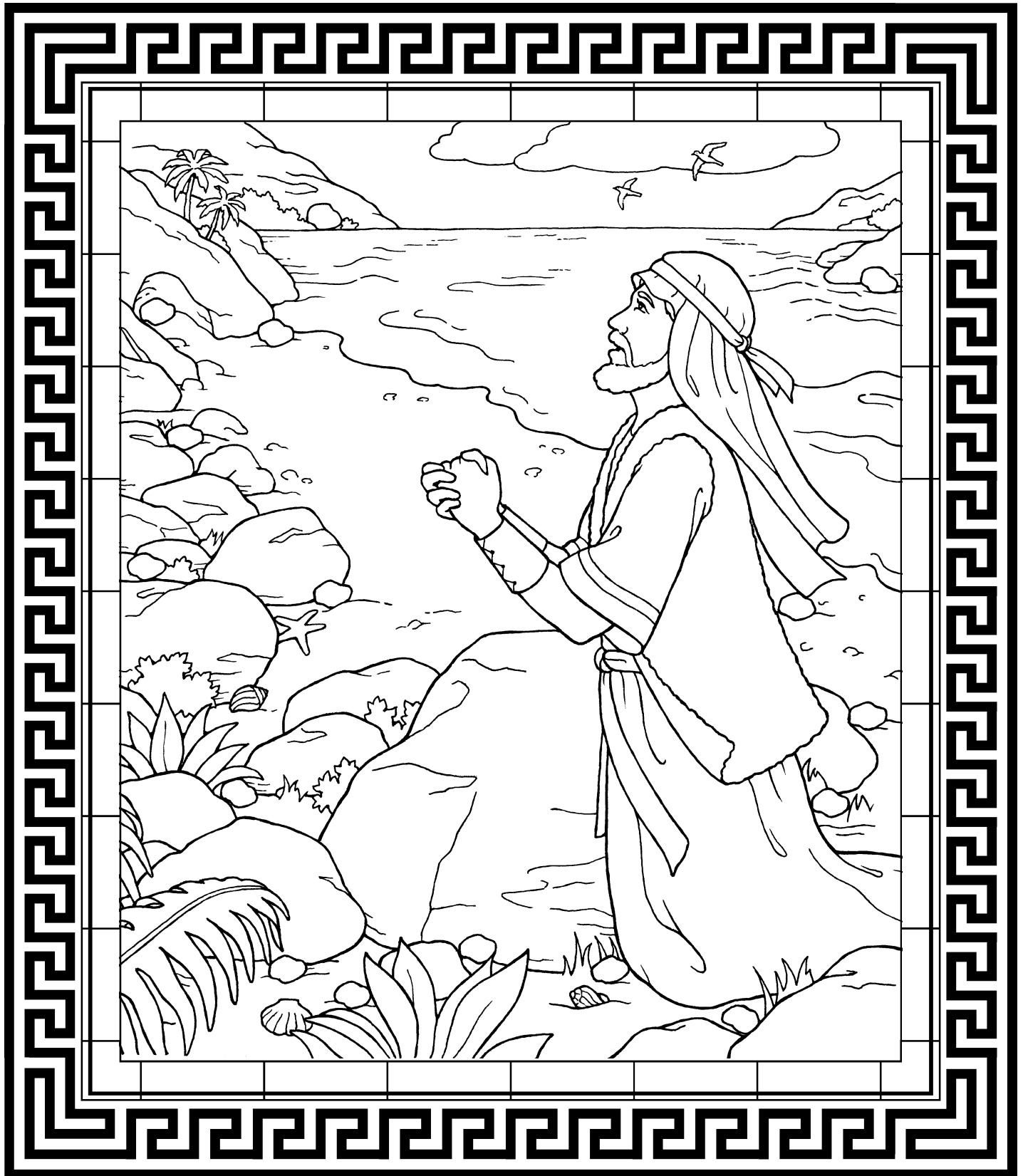
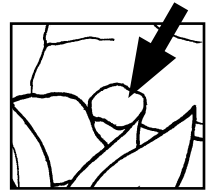



I Will Bring You up Again out of the Depths, by Jonathan Arthur Clarke

NOVEMBER 16–22

Ether 6–11

“THAT EVIL MAY BE DONE AWAY”

The ideas in this outline are not instructions you must follow. They are meant to spark your creativity and invite inspiration.

RECORD YOUR IMPRESSIONS _____



Invite Sharing

Use pictures from this week’s and last week’s outlines in *Come, Follow Me—For Individuals and Families* to help the children review what they’ve learned about the Jaredites crossing the sea. Let them take turns sharing what they know.



Teach the Doctrine: Younger Children

ETHER 6:2–12

Heavenly Father can comfort me when I am scared.

It must have been frightening for the Jaredites to be “tossed upon the waves of the sea before the wind” (Ether 6:5). But the Lord kept them safe and helped

them. How can you help the children turn to the Lord when they feel afraid?

Possible Activities

- Using words and phrases from Ether 6:2–12, describe to the children the Jaredites’ journey across the sea. Invite the children to pretend to climb into the barges and pretend that their barge is being moved and covered by waves. How would it feel to be in a real barge in rough waters? What can we do when we are scared? Read together verses 7 and 9 to see what the Jaredites did when they were frightened.
- Tell about a time when you were afraid and Heavenly Father comforted you. Share with the children a hymn or song that helps you “thank and praise the Lord” (Ether 6:9) for His help. Let the children share their favorite Primary songs, and sing some of them together.
- Use this week’s activity page to help the children make paper barges. Explain that the barges helped the Jaredites stay safe even when they were surrounded by water (see Ether 6:7, 10). What has Heavenly Father given us to keep us safe on our journey back to Him?

ETHER 6:9, 12, 30; 7:27; 10:2

I can be thankful.

After arriving safely in the promised land, the Jaredites were so thankful that they “shed tears of joy” (Ether 6:12). How can you encourage a spirit of thankfulness in the children you teach?

Possible Activities

- Read to the children phrases from Ether 6:9 and 12 to teach them how the Jaredites showed their gratitude to the Lord for helping them reach the promised land. Ask the children to name some things they are thankful for. Sing together, like the Jaredites did, a song that expresses gratitude, such as “I Thank Thee, Dear Father” (*Children’s Songbook*, 7).
- Read to the children Ether 10:2 to show that even many years later, the Jaredites remembered how the Lord had helped their ancestors cross the ocean. Help the children think of ways the Lord has blessed them. Then let the children draw pictures to remind themselves of these blessings (or help them choose from some pictures you bring, perhaps from a Church magazine).

ETHER 7:24–27

I am blessed when I follow the prophet.

The book of Ether clearly shows that when the Jaredites followed the prophets they were blessed, and when they rejected the prophets their lives were harder. Think of ways you can help the children see that the same is true for us.

Possible Activities

- Show a picture of the living prophet, and ask the children what they know about him. What does a prophet do? Explain that the Jaredites had prophets too, and whenever they followed the prophet, they were blessed and happy (see Ether 7:24–27). How can we follow the prophet?

- Sing together a song about prophets, such as “Follow the Prophet” (*Children’s Songbook*, 110–11; see also *Gospel Art Book*, nos. 4–27, 67–87). Talk with the children about things the prophets have taught us to do (for example, reading our scriptures daily, keeping the Sabbath day holy, or serving others), and invite them to act out obeying that counsel when you say “Follow the prophet!”



Teach the Doctrine: Older Children

ETHER 6:2–12

I can trust Heavenly Father to guide me to eternal life.

The account of the Jaredites’ voyage across the sea can be compared to our journey through mortality. Both journeys are sometimes dangerous and require faith that the Lord will guide and protect us.

Possible Activities

- Read together Ether 6:2–12, pausing frequently so the children can draw pictures of what they are reading. How is the Jaredites’ journey like our lives? Help the children identify and label what different parts of their drawings might represent in our lives. For example, the Jaredites could represent us. The barges could represent our homes, the Church, or the gospel. What might the wind, the water, the shining stones, and the promised land represent?
- Help the children find words and phrases in Ether 6:2–12 that show how the Jaredites trusted God. Share examples of how relying on God has helped you during difficult times in your life. Encourage the children to share any similar experiences they’ve had.



Minerva K. Teichert (1888–1976), *Journey of the Jaredites across Asia*, 1935, oil on linen on masonite, 35 x 48 inches. Brigham Young University Museum of Art

ETHER 6:30; 7:27; 10:2

Remembering what the Lord has done for me brings peace.

One thing that distinguished the righteous Jaredite kings from the wicked ones is that the righteous kings “remembered the great things that the Lord had done” for them (Ether 7:27). How can you inspire the children to remember what the Lord has done for them?

Possible Activities

- Ask the children to read Ether 6:30; 7:27; and 10:2 individually or in small groups and find something that these verses have in common. Share your feelings about what the Lord has done for you, and invite the children to do the same.
- Share with the children about how you try to remember ways the Lord has blessed you and your family. Help the children think of ways they can remind themselves what the Lord has done for them. Give them each a piece of paper, and invite them to ponder and write down something He has done for them recently. Suggest that they make a regular habit of writing down blessings they notice from the Lord (see “O Remember, Remember” [video, ChurchofJesusChrist.org]).

ETHER 9:28–35; 11:5–8

The Lord is merciful when I repent.

Even though the Jaredites often rejected the prophets and became wicked, the Lord always forgave them when they humbled themselves and repented.

Possible Activities

- Read together Ether 9:28–35, and help the children think of three or four short sentences that summarize what happened in these verses. Then read Ether 11:5–8, and help the children identify similarities between the two accounts. What do we learn from these stories?
- Ask the children to think of other people in the Book of Mormon who humbled themselves and were forgiven. Use pictures from the *Gospel Art Book* or *Come, Follow Me—For Individuals and Families* to help them remember. Bear your testimony that the Lord forgives us when we sincerely repent.



Encourage Learning at Home

Invite the children to share with their families something Heavenly Father has done for them that they are grateful for.

Improving Our Teaching

Help the children be creative. “As you teach children, allow them to build, draw, color, write, and create. These things are more than fun activities—they are essential to learning” (*Teaching in the Savior’s Way*, 25).

Heavenly Father comforts me when I am scared (Ether 6:2-12).

Color and cut out the barge and the pictures. Fold the barge on the dotted lines. Glue or tape the corresponding "1" and "2" deck tabs together, then glue or tape the "1" and "2" keel tabs to the corresponding deck tabs on top. Use the barge and the pictures to tell the story of the Jaredites traveling inside the barges to the promised land.

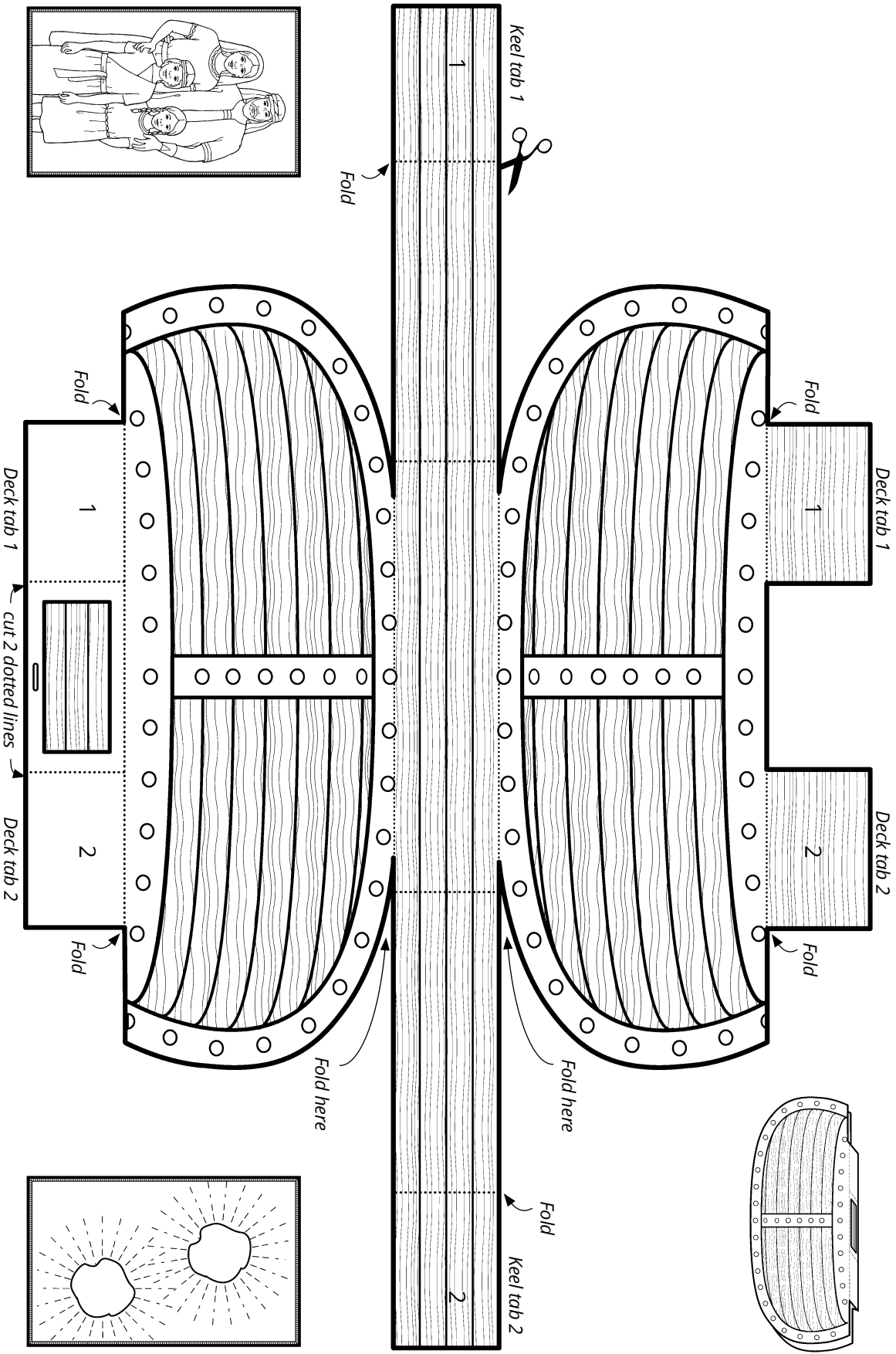



Ether Hiding in the Cavity of a Rock
by Gary Ernest Smith

NOVEMBER 23-29

Ether 12-15

“BY FAITH ALL THINGS ARE FULFILLED”

As you read Ether 12-15, think about the children you teach. The activity ideas in this outline may inspire you with other ideas that will help to meet the needs of the children in your class.

RECORD YOUR IMPRESSIONS _____



Invite Sharing

Help the children think of scripture stories about people who showed great faith. Some examples are found in Ether 12:11-22.



Teach the Doctrine: Younger Children

ETHER 12:6-22

Faith is believing in things we cannot see.

Moroni shared several examples of people who accomplished great things because of their faith. Consider how you can use these examples to teach the children what faith is.

Possible Activities

- Read to the children “Faith is things which are hoped for and not seen” from Ether 12:6, and ask them to repeat this phrase with you. Tell the children about things you believe in even though you cannot see them, and help the children think of additional examples. The song “Faith” (*Children’s Songbook*, 96-97), or another song about faith, can help.
- Show pictures that depict the examples of faith in Ether 12:13-15, 20-21 (see *Gospel Art Book*, nos. 78, 85, and this week’s activity page). Let the children tell you what they see in the pictures and what they know about the stories. Talk with the children about how these individuals showed faith and what happened because of their faith.
- Play a guessing game with the children. Give them clues about the faithful people described in Ether 12:13-15, 19-20 until the children can guess who they are. Then let the children play the game again by taking turns giving clues about the same people (or other faithful people) while the rest of the class guesses. Share what you admire about the faith of these people.

ETHER 12:23–27**Jesus Christ can help me be strong.**

Children sometimes face situations in which they feel weak, just as Moroni did. Help them learn what Moroni learned—that the Savior can “make weak things become strong” (Ether 12:27).

Possible Activities

- Describe for the children a task that would require a lot of physical strength to accomplish. Invite them to share examples of things they aren’t strong enough to do now. How could we become strong enough to accomplish these tasks? Explain that we also have spiritual work to do, but we sometimes feel spiritually weak. Moroni felt this way about his writings on the plates. Read Ether 12:27 to the children. What did the Lord promise those who feel weak?
- Share an experience in which the Savior helped you or someone you know do something that was hard. Testify to the children that if they seek His help, Jesus can help them be strong, even when they feel weak.



Teach the Doctrine: Older Children

ETHER 12:5–6**Faith is believing in things we cannot see.**

The children you teach are building the foundation of their testimonies. Moroni’s counsel about faith, found in Ether 12:6, can help them.

Possible Activities

- Explain that the prophet Ether tried to teach the Jaredites “great and marvelous things,”

but they didn’t believe what he said. Invite the children to read Ether 12:5 to find out why they didn’t believe. What are some things Heavenly Father wants us to believe even though we don’t see them? Read together Ether 12:6. What did Moroni teach the people who would not believe spiritual truths because they couldn’t see them?

- Show one of the children a picture without letting the other children see, and ask the child to describe the picture to the rest of the class. As time allows, let other children take turns doing the same with different pictures. Then invite them to read Ether 12:6 and find this phrase: “Faith is things which are hoped for and not seen.” How do we show faith in Jesus Christ when we cannot see Him?
- Ask the children to read this phrase in Ether 12:6: “Ye receive no witness until after the trial of your faith.” Help the children understand that when we obey a commandment, we can know it is true. Ask them to think of gospel principles that God wants us to have a testimony of, such as paying tithing, keeping the Sabbath day holy, or living the Word of Wisdom. Then write on the board *In order to gain a testimony of _____, I must _____*. Share how you have exercised faith in order to gain your testimony of these and other gospel truths.

ETHER 12:4, 32**Hope is like an anchor to my soul.**

Help the children you teach understand that we can “hope for a better world” because of our faith in Christ (Ether 12:4).

Possible Activities

- Share with the children the definition of *hope* found in “Hope” (Guide to the Scriptures, scriptures.ChurchofJesusChrist.org). According to this definition and Ether 12:4, 32, what should we hope for? (see also Moroni 7:40–42). Help the children think of other words for *hope*, along with words that mean the opposite of *hope*. Share with

them some gospel truths that give you hope, and invite them to do the same.

- Show (or draw on the board) a picture of a boat and an anchor. Why do boats need anchors? What would happen to a boat that did not have an anchor? Read together Ether 12:4, and ask the children how hope is like an anchor. Invite the children to draw their own pictures of a boat and anchor so they can teach their families about hope.

ETHER 12:23–29

Jesus Christ can help me be strong.

As children get older, they become more aware of their weaknesses. Use these verses to teach them how the Savior can make “weak things become strong” (Ether 12:27).

Possible Activities

- Ask the children to read Ether 12:23–25 to find out why Moroni was concerned. Ask them if they have ever had similar feelings. Then invite them to read verses 26–27 to find out how the Lord encouraged Moroni. What do we need to do so that the Lord can help us be strong when we feel weak? Share an experience when the Savior helped you become strong enough to do something that was hard.
- Invite the children to draw a picture of something weak and something strong. Then invite them to add to their drawing some words and phrases from Ether 12:23–29 that teach them about how the Savior can help us turn our weakness into strength. Encourage the children to think about a weakness they might have and then seek the Savior’s help to become strong.



Encourage Learning at Home

Invite the children to write down a truth they would like to gain a testimony of. Help them set a goal to exercise faith so they can gain a witness of that truth.

Improving Our Teaching

Seek to understand the children you teach.

“Look for ways to understand the backgrounds, interests, talents, and needs of the [children] you teach. Ask questions, listen carefully, and observe what learners say and do in different situations. . . . Ask their parents for insights. Above all, pray for the understanding that only the Spirit can give” (*Teaching in the Savior’s Way*, 7).

Faith is believing in things we cannot see (Ether 12:13-15, 20-21).

Cut out the rectangle and the individual squares. Fold the rectangle on the dotted line so that the pictures can stand up. Match the cards to the people who saw miracles because of their faith.

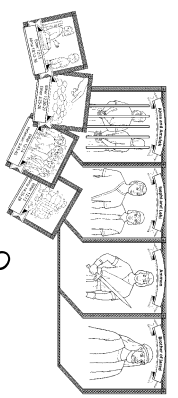

| | | | |
|---|------------------------------|---------------------|--------------------------------|
| <p>Alma and Amulek</p> | <p>Nephi and Lehi</p> | <p>Ammon</p> | <p>Brother of Jared</p> |
| <p>fold</p> <hr style="border-top: 1px dotted black;"/> <p>fold</p> | | | |

Ether 12:15
Alma 18:12-36

Ether 12:20-21
Ether 3:25-26

Ether 12:14
Helaman 5:43-45

Ether 12:13
Alma 14:26-29



Minerva K. Teichert (1888–1976), *Alma Baptizes in the Waters of Mormon*, 1949–1951, oil on masonite, 35½ x 48 inches. Brigham Young University Museum of Art, 1969

NOVEMBER 30–DECEMBER 6

Moroni 1–6

“TO KEEP THEM IN THE RIGHT WAY”

Before you begin planning learning activities for the children, prayerfully study Moroni 1–6, looking for principles and verses that you feel they need to understand.

RECORD YOUR IMPRESSIONS _____



Invite Sharing

Invite the children to share what they have been learning about Moroni. You could use “Chapter 53: Moroni and His Teachings” (*Book of Mormon Stories*, 154–55, or the corresponding video on ChurchofJesusChrist.org) to help them remember.



Teach the Doctrine: Younger Children

MORONI 4–5

I take the sacrament to show that I will always remember Jesus Christ.

The sacrament can be a sacred spiritual experience—even for young children. How can you help the children you teach use the time during the sacrament to think of Jesus?

Possible Activities

- Show a picture of people partaking of the sacrament (see this week’s outline in *Come, Follow Me—For Individuals and Families* or *Gospel Art Book*, no. 108). Ask the children to tell you what happens during the sacrament. What should we be doing during the sacrament?
- Invite two ward members to come to class to read Moroni 4:3 and 5:2 to the children and share why they take the sacrament every week. Ask them to suggest things the children can do to help them think about Jesus during the sacrament and remember Him always.
- Sing a song that helps the children think about Jesus, such as “Reverently, Quietly” (*Children’s Songbook*, 26). Ask the children to practice sitting reverently like they would during the sacrament.

MORONI 6:1–3

I can prepare to be baptized.

Moroni’s description of people who were baptized in his day can help the children prepare to receive this important ordinance today.

Possible Activities

- Read phrases from Moroni 6:1–3 that teach who can be baptized. Explain terms the children may not understand. For instance, one meaning of “a broken heart and a contrite spirit” is to feel sorry for our sins (Moroni 6:2). Tell about how you prepared to be baptized, or ask someone who was recently baptized to explain how he or she prepared. Help the children think of ways they can prepare to be baptized someday.
- Display pictures of people being baptized (see *Gospel Art Book*, nos. 103, 104), and let the children talk about what they see in the pictures. Help them notice details, such as the water and the white clothing. Ask the children why we get baptized, and explain why you chose to be baptized.

MORONI 6:4–6, 9

I am blessed when I go to church.

Do the children you teach understand why we go to church every week? Moroni 6 gives some important reasons.

Possible Activities

- Ask the children why they like going to church, and help them name some of the things we do at church. Read to them some of these things from Moroni 6:4–6, 9, and invite them to act out or draw pictures of themselves doing some of these things (such as praying, preaching, singing, and partaking of the sacrament).
- Help the children sing a song about attending church, such as “When I Go to Church” (*Children’s Songbook*, 157). Tell the children why you love going to church and how it has blessed you.



Teach the Doctrine: Older Children

MORONI 2–6

The Holy Ghost is a sacred gift.

The Holy Ghost is mentioned several times in Moroni 2–6. How can you use these chapters to help the children understand how the Holy Ghost can help them?

Possible Activities

- Ask the children to find every verse in Moroni 2–6 that mentions the Holy Ghost or the Spirit. Read each of these verses together, and ask the children to list on the board the things they learn about the Holy Ghost. How can the Holy Ghost help us?
- Tell the children about a time when you felt the influence of the Holy Ghost, either at church or elsewhere. Explain how you knew it was the Holy Ghost and how He helped you. Invite the children to share any experiences they have had with the Holy Ghost, and encourage them to seek His influence.



The gift of the Holy Ghost is given through the laying on of hands.

MORONI 4-5**I take the sacrament to show that I will always remember Jesus Christ.**

When the children understand the sacredness of the sacrament, they are more likely to treat it with reverence and feel close to God during this ordinance.

Possible Activities

- Write phrases from Moroni 4:3 and 5:2 on separate strips of paper, and ask the children to put the phrases in the correct order. According to these verses, why is the sacrament important?
- Invite the children to imagine that a friend is coming to sacrament meeting for the first time. How would they explain to their friend what the sacrament is and why we partake of it? Encourage them to use Moroni 4:3 and 5:2 in their explanations.
- Invite the children to share things their families do during the sacrament to be reverent and think about Jesus Christ. What other ideas do they have? Invite them to pick one of these ideas and set a goal to spend more time thinking of the Savior during the sacrament.

MORONI 6:4-6, 9**We go to church to take the sacrament and support each other.**

Moroni's words could help the children you teach find greater purpose in coming to church each week.

Possible Activities

- Write *Why do we come to church?* on the board, and ask the children to write possible answers. Invite them to find additional answers in Moroni 6:4-6, 9 and add them to their list on the board. Invite the children to share how they have been blessed for attending church. Let them role-play

explaining to a friend of another faith why they are thankful to belong to the Church.

- Show pictures or examples of nourishing foods. Why is it important to nourish our bodies? Read together Moroni 6:4, and ask the children what they think the phrase “nourished by the good word of God” means. How does the word of God nourish us?
- Invite one of the children to read the following quotation from Elder Jeffrey R. Holland, and discuss what it teaches about how we can nourish each other: “Most people don’t come to church looking merely for a few new gospel facts or to see old friends, though all of that is important. They come seeking a spiritual experience. They want peace. They want their faith fortified and their hope renewed. They want, in short, to be nourished by the good word of God, to be strengthened by the powers of heaven” (“A Teacher Come from God,” *Ensign*, May 1998, 26). How can we help spiritually nourish each other at church?

**Encourage Learning at Home**

Encourage the children to talk to their family about reasons they like to attend church each week.

Improving Our Teaching

Support parents. Prayerfully seek ways to support the parents of the children you teach. How can you support their efforts to teach the gospel to their children? For example, you might talk to parents about the needs and interests of their children or share with them what their children are learning in class (see *Teaching in the Savior's Way*, 25).

I take the sacrament to show that I will always remember Jesus (Moroni 4-5).

Color the picture and glue it to several craft sticks or a piece of card stock.
Cut the picture into several strips to make a puzzle.

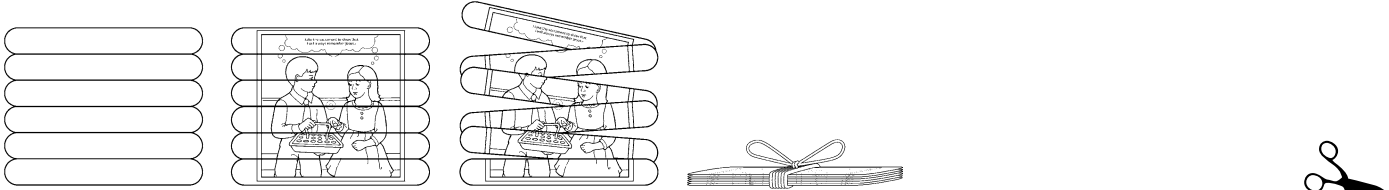



Mirreva K. Teichert (1888–1976). *Moroni: The Last Supper*. 1949–1951, oil on masonite, 34½ x 47 inches. Brigham Young University Museum of Art, 1969

DECEMBER 7–13

Moroni 7–9

“MAY CHRIST LIFT THEE UP”

Prayerfully studying Moroni 7–9 will invite the influence of the Holy Ghost. He will help you understand the needs of the children in your class.

RECORD YOUR IMPRESSIONS _____



Invite Sharing

Remind the children about something you invited them to do during last week’s lesson or something they may have learned with their families this week. Ask them to share what they learned.



Teach the Doctrine: Younger Children

MORONI 7:33

If I have faith, I can do whatever God needs me to do.

Children who have faith in Jesus Christ and confidence in His power can accomplish great things when they are serving Him.

Possible Activities

- Read Moroni 7:33, and invite the children to stand up when they hear the word “faith.” Explain that we show our faith in Jesus Christ when we keep His commandments. Help the children make a list on the board of some things Jesus wants them to do, like obeying their parents or telling the truth. Testify that our faith in Jesus Christ can help us keep the commandments.
- Display a few pictures that show someone from the Book of Mormon (or other books of scripture) accomplishing something important because he or she had faith in Jesus Christ (see, for example, *Gospel Art Book*, nos. 19, 70, 78, 81). Help the children tell the story portrayed in the picture. Tell them that because these people had faith in Jesus Christ, they were given power to do what He needed them to do.

MORONI 7:41**Believing in Jesus Christ can give me hope.**

There are many people in the world who feel that they have no hope. How can you help the children you teach find hope in Jesus Christ?

Possible Activities

- Read and explain Moroni 7:41 to the children, and ask them to raise their hands when they hear something Mormon said we should have hope for. Tell the children about the hope you feel because of Jesus Christ.
- Ask the children to think of someone they know who is having a hard time with something. Invite the children to draw a picture for the person that can remind him or her to have hope in Jesus Christ.

MORONI 7:47**“Charity is the pure love of Christ.”**

What experiences from your life might help the children learn to be kind to others and treat them with love?

Possible Activities

- Ask the children to repeat this phrase with you: “Charity is the pure love of Christ” (Moroni 7:47). Help the children think of ways Jesus Christ showed love to others (pictures might help, such as *Gospel Art Book*, nos. 55, 83, 84). How has He shown love to us? Who can we show love to as Jesus did? For an example, show the video “My Brother Hyrum” (ChurchofJesusChrist.org).
- Invite the children to draw pictures of themselves showing love to someone. Suggest that they put their picture where it will remind them to love others as Jesus does.

**Teach the Doctrine:
Older Children****MORONI 7:21–22, 25, 33****I am blessed when I have faith in Jesus Christ.**

Mormon wanted the people to know that miracles did not stop when the Savior’s earthly ministry ended. As long as we have faith in Jesus Christ, we can, with His help, do anything He needs us to do—including miraculous things.

Possible Activities

- Help the children list on the board some of the “good thing[s]” that we receive through the gospel of Jesus Christ, such as having eternal families, returning to Heavenly Father, and being forgiven of our sins. Then invite the children to read Moroni 7:21–22 and 25, looking for how we can receive all of these good things. How can we show our faith in Jesus Christ and His promises?
- Read Moroni 7:33 to the children, and ask them to listen for what we can do when we have faith in Jesus Christ. As appropriate, share experiences you have had when faith helped you do what God wanted you to do. Help the children think of and share examples from their lives. How did faith in Christ make a difference in these examples?

MORONI 7:40–41; 9:25–26**I can have hope in Jesus Christ, even during difficult trials.**

Mormon and Moroni faced discouraging circumstances, but they found hope in the Savior Jesus Christ. How can you help the children find hope in Christ when they are discouraged?

Possible Activities

- Help the children list a few problems that might make people feel discouraged or hopeless. Invite the children to read Moroni 7:40–41 and 9:25–26, looking for something that might help someone who feels discouraged. Tell them how Jesus Christ and His gospel have helped you during difficult times.
- Invite the children to write a message to someone who feels discouraged to help him or her find hope in Christ, as Mormon did for his son in Moroni 9:25–26. Encourage the children to use words and phrases from these verses in their messages.
- Fill a clear container with water, and drop two objects into it—one that floats and one that sinks. Compare the floating object to a person who has hope in Christ. Read together Moroni 9:25. How does Christ “lift [us] up” when we face difficult trials? Help the children think of ways they can keep the Savior and His encouraging teachings “in [their] mind forever.”

MORONI 7:45-48

“Charity is the pure love of Christ.”

Developing the gift of charity is a lifelong goal. How can you inspire the children to seek the pure love of Christ?

Possible Activities

- Invite the children to share what they think the word “charity” means. Then invite one of the children to read Moroni 7:45. (If some of the words in this verse are hard to understand, help the children look them up in a dictionary.) Ask the children to talk about people they know who are

good examples of charity. Why is charity called “the pure love of Christ”? (Moroni 7:47). What does verse 48 teach us about how we can be filled with charity? Encourage each of the children to pray for charity this week and to look for ways to show charity to others.

- Help the children think of ways Jesus showed charity (see, for example, Luke 23:34; John 8:1–11; Ether 12:33–34). How can we follow His example?
- Ask the children to write names of people they know on pieces of paper and place them in a small bag or container. Invite them to take their container home, select a name from it every day, and do something that shows love for that person. In a future lesson, invite them to share their experiences serving these people.



Encourage Learning at Home

Encourage the children to think of someone who might be seeking greater faith or hope in Jesus Christ. Invite the children to share with that person something they learned in class today.

Improving Our Teaching

Encourage reverence. An important part of reverence is thinking about Heavenly Father and Jesus Christ. You might remind the children to be reverent by quietly singing or humming a song or displaying a picture of Jesus.

Charity is the pure love of Christ (Moroni 7:44-48).

Color the pictures, and use scissors to cut the shape out on the solid black lines. Fold all of the dotted lines, and glue or tape the tabs to make a cube. Toss the cube and share how you can show charity in the way that lands on top. If the word *charity* lands on top, share a way the Savior showed His love.



... seeketh not her own.

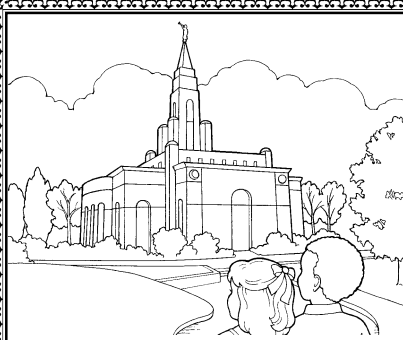

... thinketh no evil.



... is kind.



The pure love of Christ



... envieth not.



... rejoiceth in the truth.





Thou'lt Ye May Know, by Gary L. Kepp

DECEMBER 14–20

Moroni 10

“COME UNTO CHRIST, AND BE PERFECTED IN HIM”

Some children in your class may be having meaningful experiences learning from the Book of Mormon at home. How can you use those experiences to encourage all of the children to read the scriptures at home?

RECORD YOUR IMPRESSIONS _____



Invite Sharing

Pass around a copy of the Book of Mormon. When each child holds the book, ask him or her to share something he or she loves about the Book of Mormon—a favorite story, a testimony, or an experience learning from it at home or at church.



Teach the Doctrine: Younger Children

MORONI 10:3–5

I can know for myself that the Book of Mormon is true.

Look for ways to help the children accept Moroni’s invitation to ask God if the Book of Mormon is true.

Possible Activities

- Show a picture of Moroni burying the golden plates (see this week’s outline in *Come, Follow Me—For Individuals and Families*), and ask the children to describe what they see. Invite them to point to the plates, and explain that on these plates were written the words that we now read in the Book of Mormon. Let the children pretend to be Moroni writing on the plates and burying them. Sing together “The Golden Plates” (*Children’s Songbook*, 86).
- Show the Book of Mormon, and read Moroni 10:4. Emphasize that we can ask God if the Book of Mormon is true, and He will send the Holy Ghost to testify to us. You could also use “Chapter 54: The Promise of the Book of Mormon” (*Book of Mormon Stories*, 156, or the corresponding video on ChurchofJesusChrist.org). Share how the Holy Ghost has helped you gain your testimony of the Book of Mormon. Help the children understand what a witness from the Spirit feels like. Sing a song about finding truth,

such as “Search, Ponder, and Pray” (*Children’s Songbook*, 109).

MORONI 10:8–20

Heavenly Father gives me spiritual gifts.

Moroni described the gifts that God gives to His children when they have faith in Him. You can help the children have faith that God will give them spiritual gifts.

Possible Activities

- Write the numbers 9 through 16 on separate pieces of paper, and wrap each paper like a gift. Let the children take turns unwrapping the gifts. As they do, read together verses from Moroni 10:9–16 that correspond with the numbers, and help the children identify each spiritual gift. Explain that these are gifts Heavenly Father gives His children so we can help each other and do His work.
- Let the children talk briefly about favorite gifts they have received. Tell the children about spiritual gifts you have noticed that Heavenly Father has given them, such as the gifts of faith, wisdom, testimony, kindness, and the ability to learn.

MORONI 10:32

Jesus Christ wants me to come unto Him.

Consider how you will help the children understand what it means to “come unto Christ.”

Possible Activities

- Read to the children from Moroni 10:32, “Come unto Christ, and be perfected in him,” and invite the children to repeat the phrase with you. Ask them to close their eyes while you place a picture of Jesus somewhere in the room. Then let them open their eyes, find the picture, and gather around it. Discuss with the children the ways we can come unto Christ (see, for example, Articles of Faith 1:3–4). Repeat this activity, letting the children put the picture somewhere in the classroom.

- Help the children decorate heart-shaped badges that say “I love God with all my might, mind, and strength” (see Moroni 10:32). How do we show God that we love Him?



Teach the Doctrine: Older Children

MORONI 10:3–5

I can know the truth by the power of the Holy Ghost.

God wants each of us to know that the Book of Mormon is true. Help the children understand God’s promise to “manifest the truth of it unto you, by the power of the Holy Ghost.”

Possible Activities

- Write on the board the words *Read*, *Remember*, *Ponder*, and *Ask*. Invite the children to find these words in Moroni 10:3–4. What should we read, remember, ponder, and ask in order to gain or strengthen our testimonies of the Book of Mormon? Ask the children to look for similarities between these verses and the song “Search, Ponder, and Pray” (*Children’s Songbook*, 109).
- Help the children remember some of the experiences you have had together learning from the Book of Mormon. Share your feelings about the Book of Mormon, including how you have gained or strengthened your testimony that it is true. Invite the children to share their feelings and testimonies.
- Tell about a time when the Holy Ghost bore witness to you about something. Describe how you felt and how you knew it was the Holy Ghost. Help the children learn from the following scriptures about how the Spirit speaks to us: John 14:26–27; Doctrine and Covenants 6:15, 23; 8:2–3; 9:7–9; 11:12–14.

MORONI 10:8-19**Heavenly Father gives me spiritual gifts.**

There are many in our day who “deny . . . the gifts of God” (Moroni 10:8). Help the children see that these gifts still exist today.

Possible Activities

- Write the gifts named in Moroni 10:9–16 on strips of paper, and put them in a gift box. Write the numbers 9 through 16 on the board, and invite the children to take turns picking a paper from the box and matching it to the verse number on the board. What do we learn about these gifts from verses 8 and 17–18?
- Share the story of the coming forth of the Book of Mormon (see “Chapter 3: The Angel Moroni and the Gold Plates,” *Doctrine and Covenants Stories*, 13–17). Help the children identify the gifts mentioned in Moroni 10:9–16 that God gave to Joseph Smith so he could bring forth the Book of Mormon. Why does Heavenly Father want us to believe in spiritual gifts today?

MORONI 10:32-33**Jesus Christ wants me to come unto Him.**

How will you invite the children to “come unto Christ, and be perfected in him”?

Possible Activities

- Write on the board a question like *What does it mean to come unto Christ?* Help the children search

Moroni 10:32–33 to find possible answers. Work together to list what Christ wants us to do and what He promises to do for us.

- Share your favorite passages or stories from the Book of Mormon that have helped you come unto Christ, and invite the children to do the same. Review with the children the Prophet Joseph Smith’s words from the introduction to the Book of Mormon: “A man would get nearer to God by abiding by [the Book of Mormon’s] precepts, than by any other book.” Bear your testimony about how this has happened in your life.

**Encourage Learning at Home**

Invite the children to pray for a stronger testimony of the Book of Mormon and then to share their testimony with a family member or friend.

Improving Our Teaching

Encourage sharing. Young children often have meaningful insights about the gospel. Sharing their thoughts helps prepare them to talk to their friends about the gospel (see *Teaching in the Savior’s Way*, 30.)

Jesus Christ wants me to come unto Him (Moroni 10).

Cut out the rectangle on the solid black lines and fold the paper on the dotted lines to make a small booklet.

fold 2

Jesus Christ wants me to come unto Him.

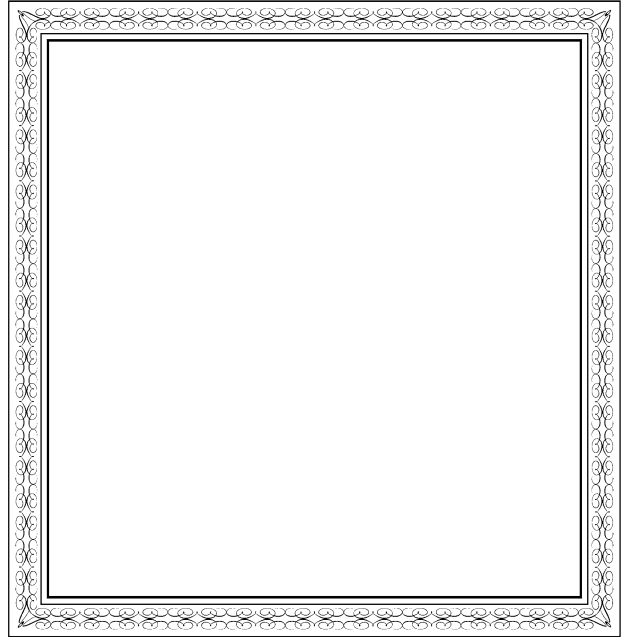
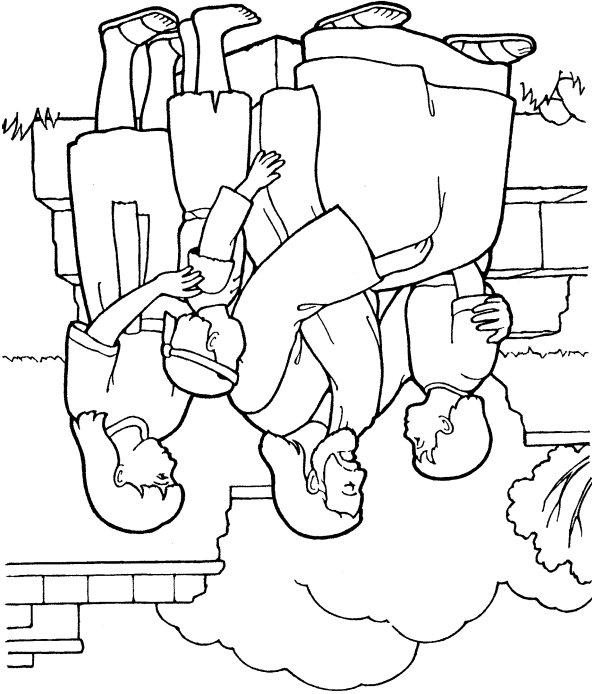

Draw a picture of your favorite person
in the Book of Mormon.

fold 1

Write your testimony of
the Book of Mormon:

THE BOOK OF MORMON

Another
Testament
of
Jesus Christ



Behold the Lamb of God, by Walter Rane

DECEMBER 21–27

Christmas

“HE SHALL COME INTO THE WORLD TO REDEEM HIS PEOPLE”

Children are often eager to talk about how they celebrate Christmas. Ponder what you can do to help them focus on Jesus Christ and their gratitude for His birth.

RECORD YOUR IMPRESSIONS _____



Invite Sharing

Invite the children to tell about or draw a picture of something their family does at Christmastime to help them remember Jesus Christ.



Teach the Doctrine: Younger Children

**1 NEPHI 11:13–22; MOSIAH 3:5–8; ALMA 7:9–13;
HELAMAN 14:1–6; 3 NEPHI 1:15, 19–21**

Jesus Christ was born to be my Savior.

Do the children you teach know why we celebrate Christmas? How can you help them understand why the birth of Jesus Christ is a cause for celebration?

Possible Activities

- Tell about Jesus’s birth, displaying pictures as you do (such as *Gospel Art Book*, nos. 28, 29, 30, 31). Let the children share what they know. Use this week’s activity page to teach the children that people living in Book of Mormon times knew about Jesus’s birth.
- Read key phrases from Alma 7:11–12 to teach the children what Jesus Christ did for us. Share why you are grateful that Jesus Christ was born, and express your feelings about His atoning sacrifice.
- Show pictures depicting the Savior’s atoning sacrifice—such as His suffering in Gethsemane, death on the cross, and Resurrection (see *Gospel Art Book*, nos. 56, 57, 58, 59). Ask the children to tell you what they see in the pictures. Help them understand that Heavenly Father sent Jesus Christ to earth to suffer for our sins, die for us, and be resurrected so that we can return to live with Him.
- Sing with the children a song about Jesus’s birth, such as “He Sent His Son” or “Away in a Manger” (*Children’s Songbook*, 34–35, 42–43).

Point out to the children phrases in the song that describe blessings we have because of Jesus’s birth.

2 NEPHI 25:23, 26

The Book of Mormon testifies of Jesus Christ.

As you conclude your study of the Book of Mormon this year, remind the children that this book is “Another Testament of Jesus Christ,” written to help us come unto Him.

Possible Activities

- Hold up a copy of the Book of Mormon for the children to see. Read the title and point to the words “Another Testament of Jesus Christ.” Let the children take turns holding the book, and help them find the Savior’s name on the cover. Tell the children how you feel about the Book of Mormon and how it has helped you learn about Jesus Christ.
- Give each child a picture of Jesus, or let them draw their own pictures of Him. Invite them to hold up their pictures each time they hear Christ’s name as you read 2 Nephi 25:23, 26. Testify that the Book of Mormon was written to help us “believe in Christ” (2 Nephi 25:23).
- Share with the children one of your favorite passages or stories from the Book of Mormon that helps you learn about Jesus Christ. Ask the children about their favorite stories in the Book of Mormon, and help them see how these stories help us learn about the Savior and come closer to Him. Looking at some of the pictures in *Book of Mormon Stories* could help them remember the stories.



Teach the Doctrine: Older Children

**1 NEPHI 11:13–22; MOSIAH 3:5–8; ALMA 7:10–13;
HELAMAN 14:1–6; 3 NEPHI 1:15, 19–21**

Jesus Christ was born to be my Savior.

Ponder how you can best help the children understand the significance of Christ’s birth and what it means for them.

Possible Activities

- Give each child one of the scripture references found on this week’s activity page. Invite them each to read their scripture, identify the prophet who was speaking, and share one thing that this prophet knew about Jesus Christ. Give them help or let them work together if needed.
- List on the board some of the events surrounding Jesus’s birth, as described in Luke 2:4–14; Matthew 2:1–2; and 3 Nephi 1:15, 19–21. Help the children search these scriptures to determine whether the events happened in Bethlehem, the Americas, or both. Why are we thankful to have the Book of Mormon as a second witness of Jesus Christ’s birth and mission as the Savior?
- Read Alma 7:10–13 with the children. What do we learn from these verses about Jesus’s birth? about His divinity? about His mission on earth? Invite the children to share why they are grateful for Jesus Christ, and share your testimony of Him.

2 NEPHI 25:23, 26; 33:4, 10

The Book of Mormon testifies of Jesus Christ.

Speaking about the Book of Mormon, the Prophet Joseph Smith said that “a man would get nearer to God by abiding by its precepts, than by any other book” (introduction to the Book of Mormon). How can you help the children understand this promise?

Possible Activities

- Give one of the following verses to each child: 2 Nephi 25:23, 26; 33:4, 10. Invite the children to read their verse and identify what the Book of Mormon prophet Nephi wanted us to know. Ask them to write what they find on the board. Explain that these things describe an important purpose of the Book of Mormon. Let the children role-play with each other how they would explain to a friend an important purpose of the Book of Mormon.
- Share with the children one of your favorite passages or stories from the Book of Mormon that helps you learn about Jesus Christ. Ask the children about their favorite stories in the Book of Mormon, and help them see how these stories help us learn about the Savior and come closer

to Him. Share with the children how the Book of Mormon has helped you know that Jesus is the Christ. Encourage the children to think of a verse or story from the Book of Mormon that strengthens their belief in Jesus Christ. Ask them to share it with a friend or family member who doesn't know about the Book of Mormon.



Encourage Learning at Home

Invite the children to share with their family how the Book of Mormon has helped them learn more about Christ. Encourage them to share a verse or story from the Book of Mormon as part of their testimony.

Improving Our Teaching

Children love stories. Stories are one of the best ways to help children learn and remember truths. As you share the story of Jesus's birth, consider also sharing stories from your life that have helped to strengthen your faith in the Savior.

Jesus Christ was born to be my Savior

(1 Nephi 11:13-22; Mosiah 3:5-8; Alma 7:10-13; Helaman 14:1-6; 3 Nephi 1:15, 19-21).

Read the scripture references below and write the name of the person that knew about the Savior's birth in the related section (reading the chapter headings can help).

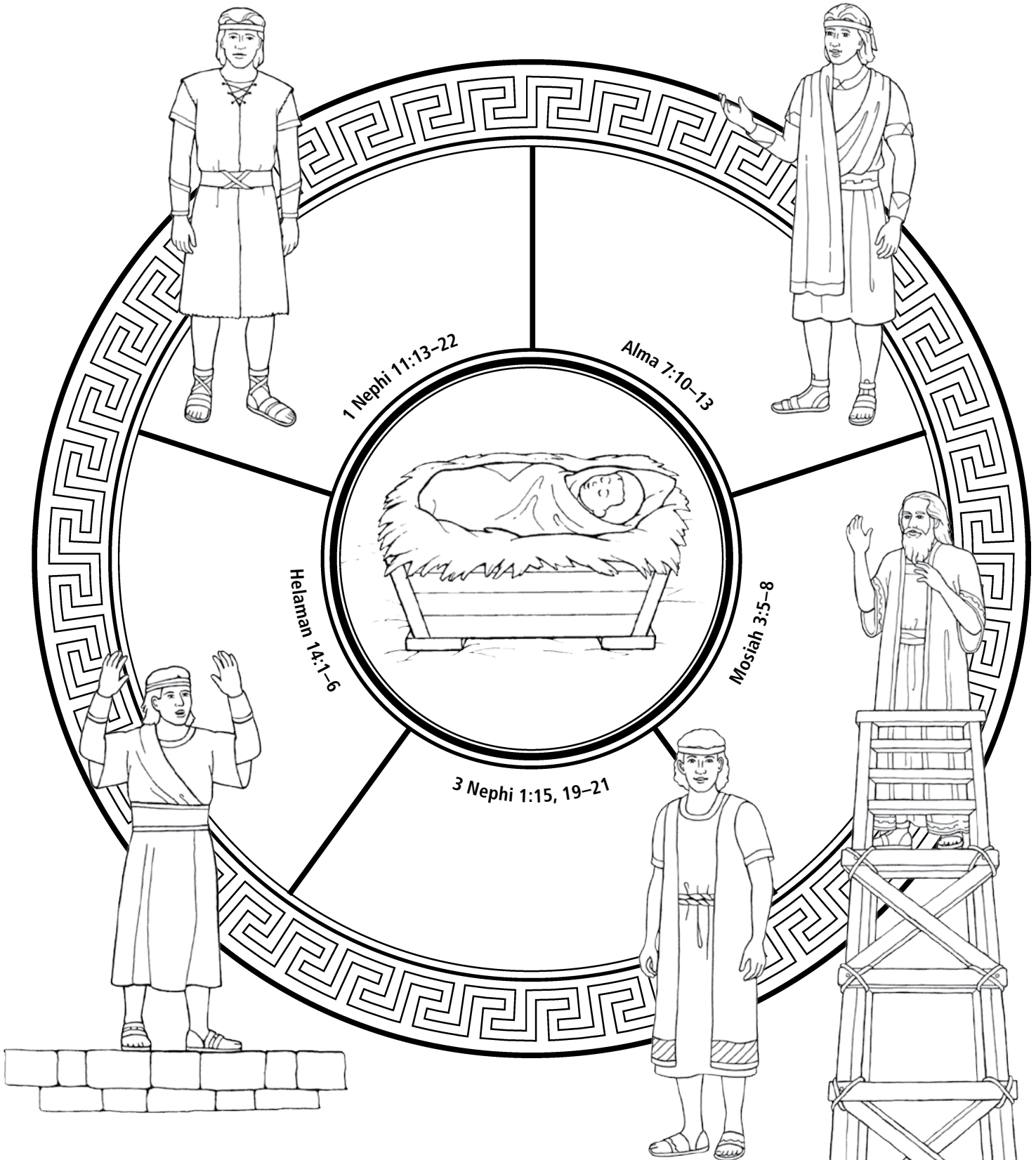



Instructions for Singing Time and the Children’s Sacrament Meeting Presentation

Dear Primary Presidencies and Music Leaders,

Primary songs are a powerful tool to help children learn about Heavenly Father’s plan of happiness and the foundational truths of the gospel of Jesus Christ. As children sing about gospel principles, the Holy Ghost will testify of their truthfulness. The words and music will stay in the children’s minds and hearts throughout their lives.

Seek the help of the Spirit as you prepare to teach the gospel through music. Share your testimony of the truths you sing about. Help the children see how the music relates to what they are learning and experiencing at home and in Primary classes. The children and their families will be blessed by your devoted efforts.

We love you and extend our gratitude for the dedicated service you are giving to fortify and protect our precious children.

The Primary General Presidency

Guidelines for the Sacrament Meeting Presentation

Under the direction of the bishop, the children’s sacrament meeting presentation is normally held during the fourth quarter of the year. As the Primary presidency and music leader, arrange to meet early in the year with the counselor in the bishopric who oversees Primary to begin discussing plans for the

presentation. When you have completed the plans, obtain his approval for them.

The presentation should allow the children to present what they and their families have learned from the Book of Mormon at home and in Primary, including the Primary songs they have sung during the year. Prayerfully consider which gospel principles and songs support what they have learned. Throughout the year, keep notes of children’s talks

and personal experiences for possible use in the presentation. Invite children to share scriptures, stories, and their testimonies in the presentation. As you plan the presentation, think of ways it can help the congregation focus on the Savior and His teachings.

Units with small numbers of children may consider ways in which family members can participate with their children. A member of the bishopric may conclude the meeting with brief remarks.

As you prepare the presentation, remember the following guidelines:

- Practices should not take unnecessary time away from Primary classes or families.
- Visuals, costumes, and media presentations are not appropriate for sacrament meeting.

See *Handbook 2: Administering the Church*, 11.5.4.

Instructions for Singing Time

5 minutes (Primary presidency): Opening prayer, scripture or article of faith, and one talk

20 minutes (music leader): Singing time

The Primary presidency and music leader select songs for each month to reinforce principles the children are learning in their classes and at home. A list of songs that reinforce these principles is included in this guide. These songs are also suggested in the outlines in *Come, Follow Me—For Primary*.

As you teach songs to the children, invite them to share what they have already learned about the stories and doctrinal principles the songs teach. You may want to review the *Come, Follow Me—For Primary* outlines that the children are studying in their classes. This will help you become aware of the

stories and principles they are learning so you can consider how to support their learning with music.

During singing time, you can also review songs the children have previously learned and songs they enjoy singing. As you review, invite the children to share their thoughts and feelings about the truths found in the songs.

The *Children's Songbook* is the basic resource for music in Primary. Hymns from the hymnbook and songs from the *Friend* and *Liahona* are also appropriate. Occasionally children may sing patriotic or holiday songs that are suitable for Sunday and for the children's ages. The use of any other music in Primary must be approved by the bishopric (see *Handbook 2: Administering the Church*, 11.2.4).



Overview of Primary

Each week, Primary includes:

Singing time 25 minutes

Transition 5 minutes

Classes 20 minutes

Leaders of larger Primaries may divide children into two groups and have one group in Primary classes while the other group is in singing time. Then the two groups would switch places. In such cases, Primary leaders may need to adjust the times shown above to suit their circumstances.

Music for Singing Time

January

- “Book of Mormon Stories,” *Children’s Songbook*, 118–19
- “Keep the Commandments,” *Children’s Songbook*, 146–47
- “The Iron Rod,” *Hymns*, no. 274

February

- “Nephi’s Courage,” *Children’s Songbook*, 120–21
- “I Feel My Savior’s Love,” *Children’s Songbook*, 74–75
- “I Love to See the Temple,” *Children’s Songbook*, 95

March

- “When I Am Baptized,” *Children’s Songbook*, 103
- “Dare to Do Right,” *Children’s Songbook*, 158
- “A Child’s Prayer,” *Children’s Songbook*, 12–13

April

- “Easter Hosanna,” *Children’s Songbook*, 68–69
- “When We’re Helping,” *Children’s Songbook*, 198
- “Love One Another,” *Children’s Songbook*, 136–37

May

- “I Will Be Valiant,” *Children’s Songbook*, 162
- “Help Me, Dear Father,” *Children’s Songbook*, 99
- “Testimony,” *Hymns*, no. 137

June

- “We’ll Bring the World His Truth,” *Children’s Songbook*, 172–73
- “Follow the Prophet,” *Children’s Songbook*, 110–11

“I Want to Be a Missionary Now,” *Children’s Songbook*, 168

July

- “My Heavenly Father Loves Me,” *Children’s Songbook*, 228–29
- “Faith,” *Children’s Songbook*, 96–97
- “As I Search the Holy Scriptures,” *Hymns*, no. 277

August

- “Repentance,” *Children’s Songbook*, 98
- “The Still Small Voice,” *Children’s Songbook*, 106–7
- “Follow the Prophet,” *Children’s Songbook*, 110–11

September

- “Samuel Tells of the Baby Jesus,” *Children’s Songbook*, 36
- “I’m Trying to Be like Jesus,” *Children’s Songbook*, 78–79
- “The Wise Man and the Foolish Man,” *Children’s Songbook*, 281

October

- “Reverently, Quietly,” *Children’s Songbook*, 26
- “Families Can Be Together Forever,” *Children’s Songbook*, 188
- “The Church of Jesus Christ,” *Children’s Songbook*, 77

November

- “Jesus Said Love Everyone,” *Children’s Songbook*, 61
- “Stand for the Right,” *Children’s Songbook*, 159
- “I Thank Thee, Dear Father,” *Children’s Songbook*, 7

December

“Search, Ponder, and Pray,” *Children’s Songbook*, 109

“Away in a Manger,” *Children’s Songbook*, 42–43

“He Sent His Son,” *Children’s Songbook*, 34–35

Using Music to Teach Doctrine

Singing time is intended to help the children learn the truths of the gospel. The following ideas can inspire you as you plan ways to teach the gospel principles found in hymns and Primary songs.

Read related scriptures. For many of the songs in the *Children’s Songbook* and the hymnbook, references to related scriptures are listed. Help the children read some of these passages, and talk about how the scriptures are related to the song. You could also list a few scripture references on the board and invite the children to match each reference to a song or a verse from a song.

Fill in the blank. Write a verse of the song on the board with several key words missing. Then ask the children to sing the song, listening for the words that fill in the blanks. As they fill in each blank, discuss what gospel principles you learn from the missing words.



Quotations from Church leaders. Invite the children to listen to a quotation from a Church leader that teaches the same gospel principle as the Primary song. Ask them to raise their hand when they hear

something that helps them understand the truth they are singing about. Ask them to share what they heard.

Testify. Bear brief testimony to the children of gospel truths found in the Primary song. Help the children understand that singing is one way they can bear testimony and feel the Spirit.

Stand as a witness. Invite children to take turns standing and sharing what they learn from the song they are singing or how they feel about the truths taught in the song. Ask them how they feel as they sing the song, and help them identify the influence of the Holy Ghost.

Use pictures. Ask the children to help you find or create pictures that go with important words or phrases in the song. Invite them to share how the pictures relate to the song and what the song teaches. For example, if you are teaching the song “The Iron Rod” (*Hymns*, no. 274), you could put pictures throughout the room depicting important words from the song (such as *iron rod*, *word of God*, *guide*, *temptation*, and *heaven*). Ask the children to gather the pictures and hold them up in the correct order as you sing the song together.

Share an object lesson. You could use an object to inspire discussion about a song. For example, the song “Faith” (*Children’s Songbook*, 96–97) mentions a little seed. You could show the children a seed and talk about how we show faith when we plant a seed; this could lead to a discussion about ways we show faith in Jesus Christ, as described in the song.

Invite sharing of personal experiences. Help the children connect the principles taught in the song with experiences they have had with those principles. For example, before singing “I Love to See the Temple” (*Children’s Songbook*, 95), you could ask the children to raise their hands if they have seen a temple. Invite them to think as they sing about how they feel when they see a temple.

Ask questions. There are many questions you can ask as you sing songs. For example, you can ask

the children what they learn from each verse in the song. You can also ask them to think of questions that the song answers. This can lead to a discussion about the truths taught in the song.

Listen for answers. Ask the children to listen for answers to questions such as “who?” “what?” “where?” “when?” or “why?” For example, in the song “Nephi’s Courage” (*Children’s Songbook*, 120–21), they could listen for who was asked to get the plates and where, when, how, and why he obeyed the Lord. You could also ask the children to listen for key words or to count on their fingers how many times they sing a certain word.

Helping Children Learn and Remember Primary Songs

Children learn a song by hearing and singing it over and over again. Always sing the words of a new song to the children—don’t just read or recite them. This helps the children connect the melody to the words. After a song is taught, review it in a variety of fun ways throughout the year. Below are some ideas to help children learn and review songs.

Create posters. Display posters with the words from each verse or pictures that represent the words. As the children sing, cover up some of the words or pictures until they can sing the entire verse without the poster. You can also invite the children to help you create the posters.

Demonstrate the pitch. To help children learn the melody of a song, hold your hand in a horizontal position, and as you sing the words, move your hand up to indicate higher pitches and down to indicate lower pitches.

Echo. Invite the children to be your echo by repeating what you sing. Sing to the children a short phrase or a line, and then have them sing it back to you.

Use variation. Sing songs in a variety of ways, such as whispering, humming, clapping the beat, varying

the tempo, or singing while sitting or standing. You could also make a cube out of paper and, on each side of the cube, write a different way to sing. Invite a child to roll the cube to decide how the children will sing the song.

Sing in groups. Give each class or individual one phrase to sing while standing, and then have them exchange phrases until each class or individual has had a turn singing each phrase.

Use hand actions. Invite the children to think of simple hand actions to help them remember the words and messages of a song. For example, when you sing the second verse of “My Heavenly Father Loves Me” (*Children’s Songbook*, 228–29), you could invite the children to point to their eyes, act like butterflies, and cup their hands behind their ears. Ask them to place their hands on their hearts as they sing “Yes, I know Heavenly Father loves me.”

Girls sing, boys sing. Draw a picture of a boy and a picture of a girl, and glue or tape the pictures onto separate sticks. While reviewing a song, hold up one of the pictures to indicate who should sing that part of the song.

Basket toss. Place numbered baskets or other containers at the front of the room—as many containers as there are verses of a particular song. Invite one of the children to toss a beanbag or crumpled piece of paper into or near a numbered container. Have the children sing the verse with the same number as the container.

Match a picture to a phrase. Write each line of a song on a different piece of paper, and find a picture that represents each line. Place the pictures on one side of the room and the papers on the other side. Sing the song, and ask the children to match the pictures to the words.

Note: References to wards and bishoprics also apply to branches and branch presidencies.











THE CHURCH OF
JESUS CHRIST
OF LATTER-DAY SAINTS

