

NURSERY MANUAL

# BEHOLD YOUR LITTLE ONES



# BEHOLD YOUR LITTLE ONES

NURSERY MANUAL

Published by  
The Church of Jesus Christ of Latter-day Saints  
Salt Lake City, Utah

Your comments and suggestions about this manual would be appreciated.  
Please submit them to Curriculum Development,  
50 East North Temple Street, Room 2404, Salt Lake City, UT 84150-3200 USA  
[cur-development@ldschurch.org](mailto:cur-development@ldschurch.org)

Please list your name, address, e-mail address, ward, and stake.  
Be sure to give the title of the manual.  
Then offer your comments and suggestions about the manual's strengths  
and areas of potential improvement.

© 2008 by Intellectual Reserve, Inc.  
All rights reserved  
Printed in the United States of America

English approval: 7/08

## CONTENTS

Introduction . . . . .	1
Letter to Parents . . . . .	7
Lessons	
1. I Am a Child of God . . . . .	8
2. Heavenly Father Has a Plan for Me. . . . .	12
3. I Can Pray to Heavenly Father . . . . .	16
4. Heavenly Father and Jesus Christ Love Me . . . . .	20
5. Jesus Christ Showed Us How to Love Others . . . . .	24
6. The Holy Ghost Helps Me. . . . .	28
7. Jesus Christ Created the World for Me . . . . .	32
8. Sunday Is a Day to Remember Heavenly Father and Jesus Christ . . . . .	36
9. I Have a Body like Heavenly Father's . . . . .	40
10. I Will Take Care of My Body . . . . .	44
11. I Love My Family . . . . .	48
12. I Can Pray with My Family . . . . .	52
13. My Family Can Be Together Forever . . . . .	56
14. I Will Obey . . . . .	60
15. I Will Be Thankful . . . . .	64
16. I Will Say "I'm Sorry" . . . . .	68
17. I Will Share . . . . .	72
18. I Will Love Others. . . . .	76
19. I Can Be Happy. . . . .	80
20. I Will Be Reverent. . . . .	84
21. Joseph Smith Saw Heavenly Father and Jesus Christ. . . . .	88
22. The Book of Mormon Teaches Me about Jesus Christ. . . . .	92
23. I Love the Scriptures . . . . .	96
24. I Will Follow the Prophet . . . . .	100
25. I Belong to The Church of Jesus Christ of Latter-day Saints . . . . .	104
26. I Will Be Baptized and Confirmed. . . . .	108
27. The Sacrament Helps Me Think about Jesus Christ . . . . .	112
28. Heavenly Father Blesses Me through the Priesthood . . . . .	116
Lessons for Special Occasions	
29. Jesus Christ Was Resurrected (Easter) . . . . .	120
30. Jesus Christ Is the Son of Heavenly Father (Christmas). . . . .	124
Mini-lesson: Welcome to Nursery . . . . .	128
Mini-lesson: Happy Birthday. . . . .	129
Index of Activities . . . . .	130
Index of Visuals . . . . .	131

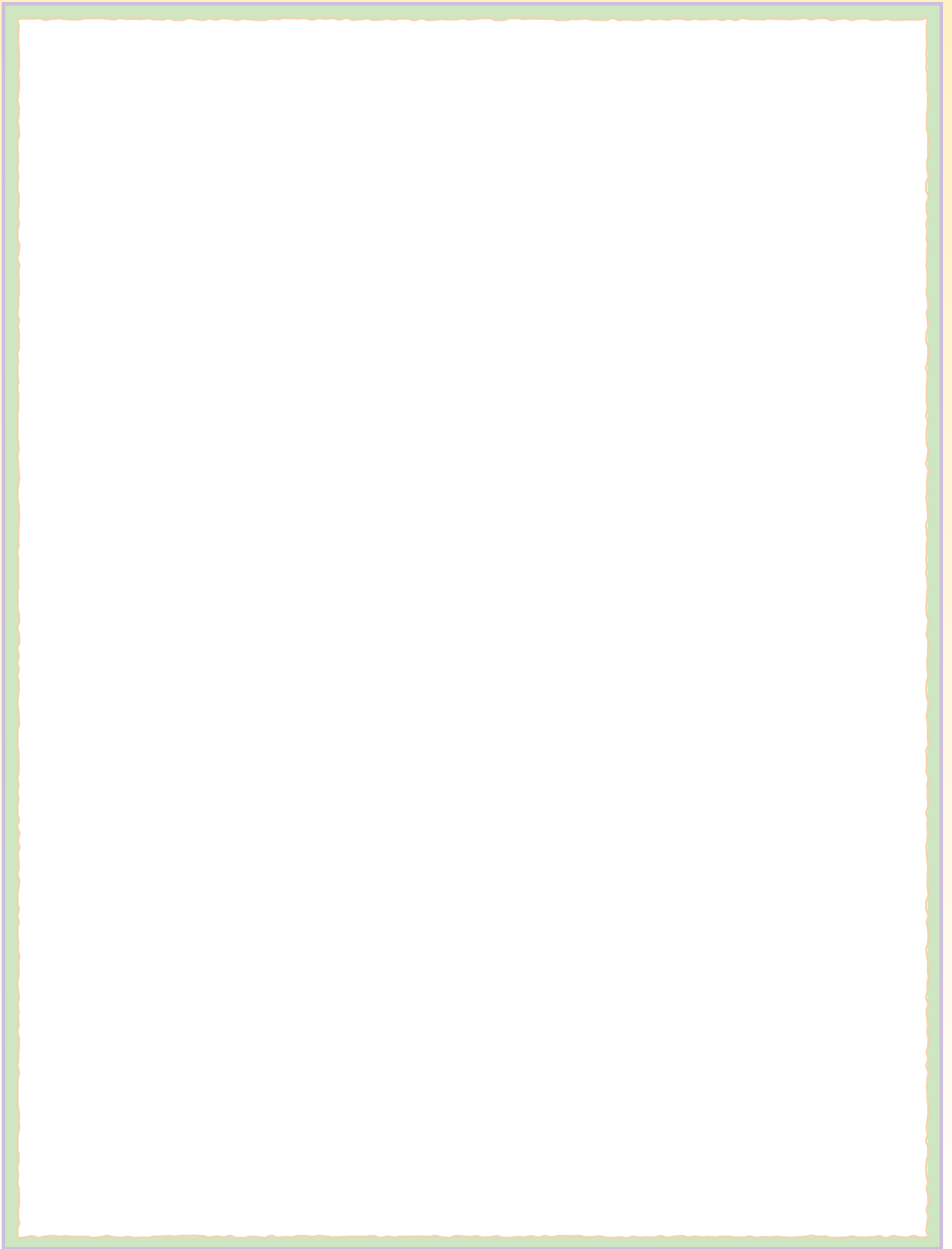

# INTRODUCTION

## THE NURSERY CLASS

**Purpose** The purpose of the nursery class is to help children learn the restored gospel of Jesus Christ and live it. The nursery class should help the children increase their understanding of and love for Heavenly Father and Jesus Christ, have positive experiences in a Church setting, and grow in feelings of self-worth.

**Letter to Parents** A few weeks before a child begins attending the nursery class, a member of the Primary presidency should give the child's parents a copy of the letter on page 7.

**Nursery Leaders** At least two people (a nursery leader and an assistant nursery leader) should be called for each nursery class. If the nursery leaders are not husband and wife, they should be of the same gender. The nursery leaders should work together during the entire nursery class to ensure the safety and well-being of the children.



**Physical Environment** The nursery class should provide a loving, safe, organized learning experience for the children. The room should be clean, cheerful, and inviting and located near a restroom if possible. Toys should be clean, safe, and in good condition. Climbing equipment should not be used.

**Schedule** The nursery class normally lasts the entire time scheduled for Primary. This time should be separated into several segments, such as lesson time, snack time, music time, and playtime.

The needs of the children will help you decide on the order of the segments and the length of each segment. Children respond well to consistency, so follow the same order each week.

- **Lesson:** Begin and end lesson time with a prayer, which should usually be given by one of the children (with help from one of the nursery leaders if needed). During lesson time, present any or all of the activities from a lesson in this manual. You can repeat these activities throughout the nursery class. Other Church-produced resources, such as the *Children's Songbook* and Church magazines, may also be helpful.
- **Play:** Allow the children to play freely with toys, puzzles, and books. Children learn through play. At the end of playtime, help the children put things away.
- **Snack:** Provide a healthy snack that is easy to manage. Ask parents if there are any foods they do not want their children to eat. Help the children wash their hands and ask a blessing on the food before they eat. Money for snacks should come from the Primary budget.

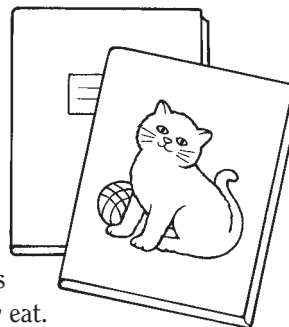

## TEACHING TIPS

For information about the characteristics of nursery-age children, see *Teaching, No Greater Call: A Resource for Gospel Teaching* (1999), 110–11.

**Schedule:** When planning the schedule for your nursery class, consider the children's needs. How long can they sit before they need to move around? When will they be hungry and need a snack? Will a quiet activity help them prepare for the lesson? Remember that many young children have short attention spans. Watch for restlessness and other behaviors that tell you the children need a change.

**Play:** Many nursery-age children are not emotionally or socially ready to share toys and other playthings. Do not force them to share if they don't want to.

- *Music:* Sing songs, play simple musical instruments, or move or march to music (see “Music in the Nursery Class,” on page 4). This segment of the nursery class can be part of the lesson time, or it can be a separate segment dedicated to music.

At the end of the nursery class, the teachers should make sure the children are picked up only by their parents or other members of their immediate family. They should not let anyone else take the children unless the parents have given their permission.

*Transitions* Provide the children with a routine that helps them change from one segment to another. For example, you could sing a song like “Fun to Do” (*Children’s Songbook*, 253), using words like, “Picking up toys is fun to do” or “Washing our hands is fun to do,” and so on.

## ABOUT THE LESSONS IN THIS MANUAL

The purpose of the lessons in this manual is to help nursery-age children learn basic doctrines of the restored gospel of Jesus Christ. Pray for guidance and seek the influence of the Spirit as you prepare to teach these lessons (see *Teaching, No Greater Call*, 97–99). You can teach them in any order, and you can teach the same lesson in consecutive weeks. You can also teach the same lesson twice during one nursery class, depending on the needs and interests of the children.

Use only Church-produced resources in the nursery class. In addition to the activities in this manual, you can use games, pictures, songs, stories, and other activities from Church magazines.

Use the scriptures as you teach the children. When a lesson suggests that you tell a story from the scriptures, open the scriptures and point to the place where the story is found. This helps the children understand that what you are teaching comes from the scriptures. Teach them to appreciate and reverence the scriptures. If you do not have your own copy of the scriptures, ask your bishop or branch president how you can obtain a copy.

As you teach these lessons, be sensitive to the home and family situations of the children. When a lesson refers to the children’s parents or families, consider the feelings of any children who are being raised by a single parent, by grandparents, or by other family members.

Also be sensitive to the feelings of any children in your nursery who have physical disabilities. Focus on the things the children *can* do, not what they cannot do. For more information about teaching those with disabilities, see *Teaching, No Greater Call*, 38–39.

The main parts of the lessons are described below:

*Introduction for the Teacher* Each lesson begins with a brief explanation of the doctrine to be taught, including scripture references. Reading and pondering this introduction and the related scriptures will help you prepare yourself spiritually to teach the doctrine to the children by the Spirit. It is not intended that this introduction be read to the nursery children.

*Learning Activities* The objective of the learning activities is to teach children the gospel by giving them opportunities to:

- Hear about the doctrine.
- See a visual related to the doctrine.
- Sing (or hear a song) about the doctrine.
- Do a physical activity related to the doctrine.
- Verbalize something about the doctrine.

## TEACHING TIPS

*Activities:* Monitor the children’s involvement during the activities. You know the capabilities and needs of the children in your nursery. Adapt the activities as needed. (See *Teaching, No Greater Call*, 33–34.)

*Activity box:* You may want to make an activity box to keep in the nursery classroom. It can contain things you have made or used for activities, such as puzzles, pictures, puppets, copies of coloring pages, and so on. You can use these items at any time during the nursery class.

Prepare a special place in the nursery room where you can gather the children close to you for the learning activities. It may be on a blanket or mat on the floor, or it may be on chairs arranged in a circle. Sit or kneel so that you are close to the children and at their eye level. (Note: Please dress appropriately for kneeling, sitting on the floor, and bending over.)



**Gathering Activities:** Begin each lesson by gathering the children with a Church-approved song or other activity. As you use the same gathering activity each week, the children will recognize the activity as a signal that lesson time is starting, and this will help them get ready for the lesson. A gathering activity can be as simple as clapping your hands rhythmically and inviting the children to clap with you. Almost any Church-approved song or activity will work if it is simple and you use it consistently every week.

Here are some other examples of gathering activities:

- Sing a song the children enjoy, such as “I Am a Child of God” (*Children’s Songbook*, 2–3) or “Love One Another” (*Children’s Songbook*, 136).
- Sing “If You’re Happy” (*Children’s Songbook*, 266), using the following words:  
If you’re ready for our lesson, come sit down.  
If you’re ready for our lesson, come sit down.  
If you’re ready for our lesson, it will surely be a blessing.  
If you’re ready for our lesson, come sit down.
- Recite the following activity verse, and invite the children to do the actions with you:  
I’m glad I came to church today, (*put fingertips together to form a steeple*)  
To learn of Jesus, sing, (*cup hands around mouth*)  
and pray. (*fold arms*)

**Optional Activities** Each lesson suggests 2 to 4 optional activities you can choose from to supplement the lesson if desired. You can also use these activities at other times during the nursery class. Many of these activities require additional preparation. If the supplies required for these activities are not available to you, you can substitute similar supplies. Money for these supplies can come from the Primary budget.

## TEACHING TIPS

**Gathering:** Praise the children who sit with you. If some of them do not want to sit, do not force them, but encourage them with a variety of activities. While one nursery leader is teaching, the other nursery leader can help direct the children’s attention.

**Songs:** If you use a song or activity verse for your gathering activity, repeat it a few times, using a softer voice each time.

**Repetition** helps children learn. If the children especially enjoy a learning activity or an optional activity, repeat it at other times during the nursery class and in future weeks.



**Visuals** Each lesson includes two pages of visuals: a color picture and a line drawing. Their purpose is to visually reinforce the principles taught in the lesson. Suggestions for using the visuals are included in the lessons.



**Teaching Tips** On the right side of each page are suggestions and ideas to help you teach the lesson successfully. Some of these are suggestions about presenting a specific activity, but most are general principles that apply anytime you are teaching small children.

## MUSIC IN THE NURSERY CLASS

Nursery-age children are ready and eager to learn about Heavenly Father and Jesus Christ, and music can help them learn. Music invites the Spirit, and it can create a warm and loving atmosphere, making the nursery class a happy place to be.

Don't worry if you aren't a talented singer. The children will listen to the words, watch your facial expressions, and enjoy the melody rather than focusing on your singing ability.

- Ways to Use Music** Music can serve a variety of purposes in the nursery class. You can use it to:
- Welcome the children. For example, you can have quiet music playing as the children enter the nursery.
  - Teach gospel principles. Most of the lessons in this manual suggest songs that relate to the topic of the lesson.
  - Help the children prepare to begin a different activity—for example, to establish a reverent atmosphere in preparation for lesson time.
  - Give the children a chance to move and enjoy themselves.
  - Familiarize the children with songs they will sing in Primary.

### *Helping Children Participate*

To teach the children a song, sing a short line a couple of times and then invite them to sing it with you. Praise them for their efforts. At first they may sing only a word or two, and the younger children might not sing at all, but they can still learn and have fun listening to you sing. They may also enjoy doing simple actions that go along with the songs. Eventually they will learn the words and begin to sing with you, especially if you repeat the songs.



## TEACHING TIPS

**Visuals:** To help the children learn from pictures and line drawings, point out details that are relevant to the principles you are teaching.

**Music:** You do not need a piano or CD player to use music in the nursery class. The children will feel comfortable if you simply gather them around you and sing. Be familiar with the words to the song so that you can maintain eye contact with the children.

**Music resources:** Consider preparing a box of music resources to keep in the nursery classroom. It could contain a list of songs and activity verses the children enjoy, simple pictures for the children to hold while you sing, or simple musical instruments.

*Other Resources* The words to several songs are included in the lessons in this manual. You can also use:

- The *Children's Songbook* and audio recordings of Primary songs. Songs that are simple and that have repeating phrases are especially appropriate for nursery-age children. You can add simple actions suggested by the words.
- The Church's music Web site, [www.lds.org/churchmusic](http://www.lds.org/churchmusic). Here you can hear the music to the songs in the *Children's Songbook* and the hymnbook.
- Assistance from your Primary music leader.

## POTENTIAL PROBLEMS AND POSSIBLE SOLUTIONS

The following are some common problems that may occur in the nursery class and some suggestions for solving them. In all situations, sincerely praise the child when he or she is behaving appropriately. Forcing children to comply is not the solution to behavior problems. Remember that it is important for every child to have a loving, enjoyable experience in the nursery class.

### PROBLEM

A parent brings a child to the nursery class, and the child cries when the parent tries to leave.

A child seems afraid of you or the other children, wanders aimlessly around the nursery, or will not interact with anyone.

A child clings to you and demands your constant attention.

A child will not sit quietly and listen during the lesson. He or she distracts or upsets the other children.

### POSSIBLE SOLUTION

Invite the parent to stay until the child is calm and settled. Try to interest the child in the activity that is taking place in the nursery class, and invite him or her to participate.

Be patient; do not pressure the child to participate. Give him or her time to get to know you, the other children, and the environment. Occasionally reassure the child, and continue to invite him or her to join an activity. Help ensure that the nursery class is a loving, enjoyable experience for the child.

Young children need warmth and attention. Talking to and interacting with the child in a loving manner will usually satisfy him or her. Then encourage the child to become involved in the nursery activities.

One nursery leader can direct the child's attention to the activity while the other leader is conducting. Giving the child something to hold can help him or her be actively involved in the lesson. You may need to have the child sit with the second teacher to allow the other children to have



a safe, productive lesson experience. Always remember to interact with the children in a loving, supportive manner.

## PROBLEM

A child stands up and walks away before an activity is finished.

The children start fighting over a toy.

A child starts to play roughly—throwing, swinging, or pounding toys.

A child begins to cry and whine. When you try to give comfort, he or she says something like, “I don’t like you” or “You’re not my mother” and pulls away.

## POSSIBLE SOLUTION

Be alert and aware of each child’s needs, interests, and attention span. Look for signs of restlessness so you can adjust the activity to fit the child’s needs. While one teacher is conducting the activity, the other teacher can invite and encourage a child who has lost interest. Do not force a child to participate in any activity.

Young children have difficulty sharing. You may need to step in to help them solve the problem or to prevent them from hurting each other. Suggest ways they can play with the toys together, or redirect their attention to other toys and activities. Make



sure there are enough playthings for each child. Praise the children for playing appropriately.

You need to intervene in this behavior. The nursery class needs to be a safe environment for the children. Lovingly explain to the child that he or she cannot play this way, and then direct the child’s attention to some other form of play. Praise the child for appropriate behavior.

Redirect the child’s attention to things happening in nursery or to a toy or book. This may help the child settle down. If he or she is inconsolable, take the child to his or her parent.

DEAR PARENTS,

We look forward to having your child in our nursery class! Here are some things you can do to make your child's experience enjoyable:

- Say positive things to your child about the nursery class during the week before he or she will first attend.
- Talk to your child about what happens in the nursery class. Help him or her know what to expect.
- Take care of your child's restroom and feeding needs before taking him or her to the nursery class. A child who needs a diaper change will be taken to a parent.
- Inform the nursery leaders if your child has a special challenge, such as a food allergy.
- Remain in the nursery class with your child if he or she is afraid.
- Tell the nursery leaders where you will be during the nursery class.
- Reassure your child that you will come back later.
- Promptly return to pick up your child at the end of the nursery class. If someone other than a parent or sibling will pick up your child, please let the nursery leaders know that this person has your permission to do so.
- Reinforce at home what is taught in the nursery lesson.
- If possible, please provide a photograph of your child and a photograph of your child's family.

Please do not bring your child to the nursery class when he or she is ill or has any of the following symptoms:

- Fever
- Runny nose
- Cough
- Unusual irritability
- Vomiting
- Diarrhea
- Rash
- Discharge from the eye
- Head lice
- An illness or infection treated with antibiotics within the last 48 hours
- An illness in the contagious period:
  - Chicken pox (seven days)
  - Measles (until rash disappears)
  - Scarlet fever (until rash disappears)
  - Mumps (until swelling is gone, usually seven days)
  - Impetigo

If your child has an allergy that is causing a runny nose, cough, or rash, please let the nursery leaders know that your child's symptoms are not contagious.

Feel free to contact the nursery leaders if you have any concerns or questions:

\_\_\_\_\_

Nursery leader

\_\_\_\_\_

Phone number

\_\_\_\_\_

Nursery leader

\_\_\_\_\_

Phone number

# 1

## I AM A CHILD OF GOD

### INTRODUCTION FOR THE TEACHER

To prepare yourself spiritually to teach this lesson, please read and ponder the following:

Each of us is a beloved spirit son or daughter of heavenly parents. We lived with them before we were born. Our Heavenly Father knows us personally and loves us. (See Psalm 82:6; Acts 17:28–29; Hebrews 12:9.)

### PREPARATION

- Bring a copy of the scriptures. Mark Psalm 82:6 and Moses 1:4 so that you can turn to them easily.
- Mark page 99 in this manual so that you can turn to it easily.

### LEARNING ACTIVITIES

Begin with a gathering activity. For ideas, see page 3.

*Prayer* Invite a child to give the opening prayer.

*Song* Sing or say the first verse of “I Am a Child of God” (*Children’s Songbook*, 2):

I am a child of God,  
And he has sent me here.

Repeat two or three times, inviting the children to sing with you.

*Scripture* Tell the children that they have mothers and fathers on earth who love them. Tell them that they also have a Heavenly Father who knows and loves them. Open the Bible to Psalm 82:6 and read, “All of you are children of [God].”

*Scripture Story* Show the illustration of Moses on page 99 (you may want to cover the other illustrations on this page to help the children focus on Moses). Explain that Moses was a great prophet who lived a long time ago. Tell the children that Moses went to a mountain to pray. Invite the children to pretend to climb a mountain; then have them fold their arms as if praying. Open the Pearl of Great Price to Moses 1:4 and say, “God said to Moses, ‘Behold, thou art my son.’” Explain that Moses learned that he was a child of God.

*Repetition Activity* Invite a child to stand next to you in the front of the class.

Say: “This is [child’s name].”

Ask the children to repeat the child’s name.

Say: “[Child’s name] is a child of God.”

Ask the children to repeat: “[Child’s name] is a child of God.”

Repeat the activity for each child in the nursery. If the nursery class is large, you could present two children at a time or shorten the activity as necessary.

*Picture* Show the picture on page 10, point to a child in the picture, and ask, “Is this person a child of God?” Nod and say yes. Repeat for each child in the picture. Then point to yourself and ask, “Am I a child of God?”



### TEACHING TIPS

**Songs:** Use music to teach gospel principles and invite the Spirit. A few of the children may try to sing with you, but most will probably just watch you while you sing. They learn songs by listening, and they enjoy the songs even if they do not sing.

**Names:** Nursery children enjoy hearing their own names and personally being part of the lesson. Show the children you love them by learning their names and praising them for participating.

Nod and say yes. Emphasize that *everyone* is a child of God and He knows and loves us all.

**Conclusion** Share your testimony that we are all children of God and that He knows and loves us.

**Prayer** Invite a child to give the closing prayer.

## OPTIONAL ACTIVITIES

**PREPARATION** *For the poster activity:* Invite parents to bring a photograph of their child to nursery (they may have already provided this photograph when the child first joined the nursery class; see page 7). At the top of a piece of poster board, write, "I Am a Child of God." Leave plenty of space for the pictures of the children.

*For the illustration activity:* Copy the illustrations on page 11 so that each child can have one.

**Activity Verse** Invite the children to stand and do the following activity verse with you:

If you're very, very tall, (*stretch and reach arms up*)

Heavenly Father knows and loves you.

If you're very, very small, (*crouch down*)

Heavenly Father knows and loves you.

Tall, (*stretch up*)

Small, (*crouch down*)

Tall, (*stretch up*)

Small, (*crouch down*)

Heavenly Father knows and loves us all.

**Poster** Attach the pictures of the children to the poster you have prepared. Read the title of the poster to the children and remind them that we are all children of God. Display the poster each week and add pictures to it as other children join the nursery.

**Illustration** Give each child a copy of one of the illustrations on page 11. Invite the children to point to different parts of the faces (such as eyes, mouth, and so on). Let the children color the illustrations, if desired.

## TEACHING TIPS

**Prayer:** If the child needs help praying, prompt him or her with short, simple phrases to repeat. The older children may be able to pray using their own words.

**Making copies:** If you don't have access to a copy machine, you could place a sheet of plain paper over the illustrations and trace them.

**Coloring:** Not all children enjoy coloring. Some may make only a mark or two on the page. The purpose of the illustrations in these lessons is to give the children a visual representation of the lesson that they can hold and take home. It is not important that they color the illustration skillfully.



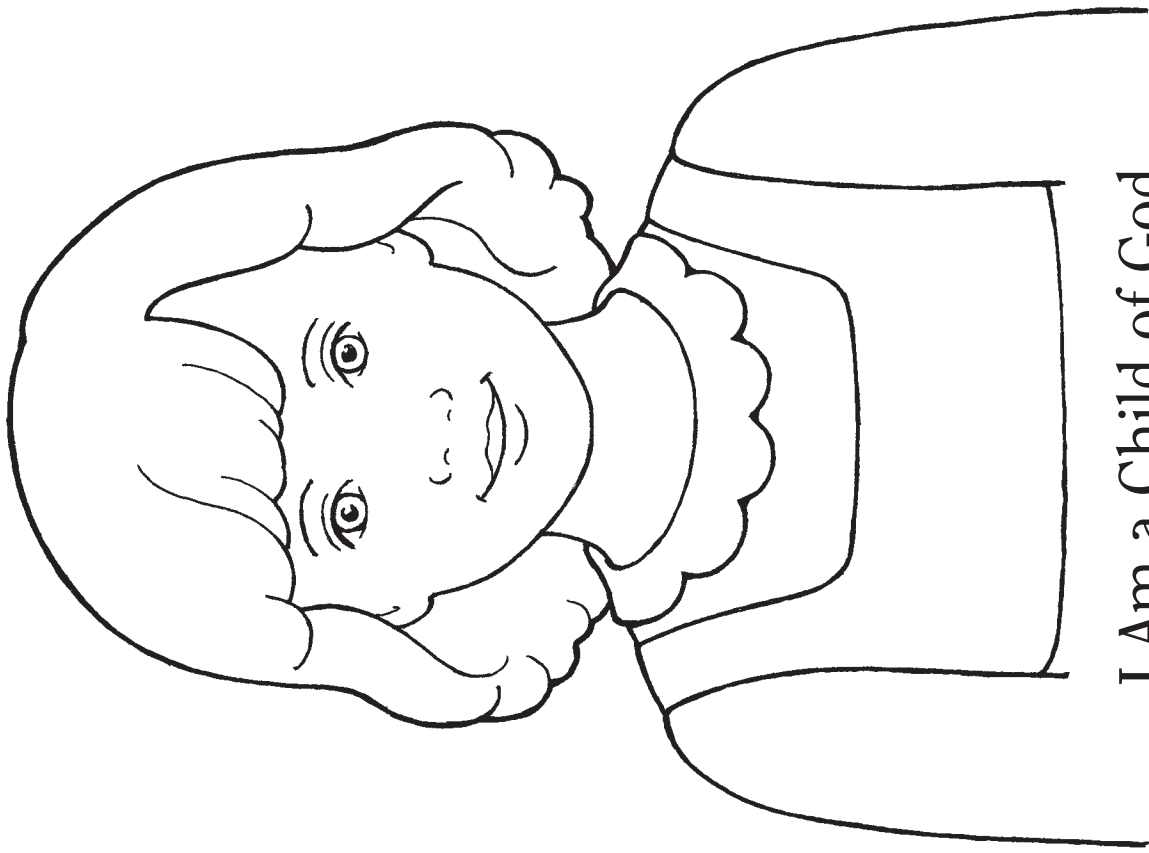

I Am a Child of God

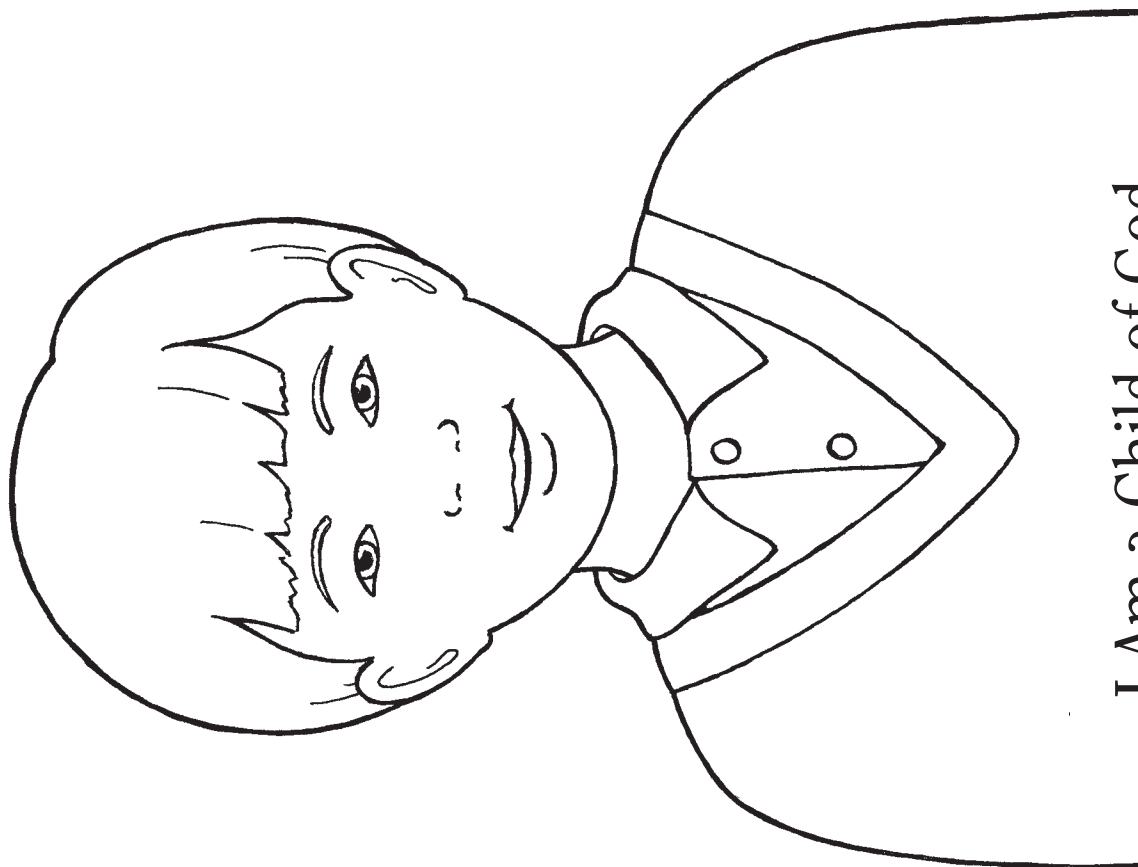

I Am a Child of God



# 2

## HEAVENLY FATHER HAS A PLAN FOR ME

### INTRODUCTION FOR THE TEACHER

To prepare yourself spiritually to teach this lesson, please read and ponder the following:

We lived with Heavenly Father as spirits before we were born. Heavenly Father prepared a plan that allows us to come to earth and receive physical bodies in order to become like Him and return to His presence. This is made possible through the Atonement of Jesus Christ and our obedience. Jesus Christ was chosen to be our Savior. (See Abraham 3:24–27; Articles of Faith 1:3.)

### PREPARATION

Mark page 98 in this manual so that you can turn to it easily.

### LEARNING ACTIVITIES

Begin with a gathering activity. For ideas, see page 3.

*Prayer* Invite a child to give the opening prayer.

*Sing a Story* Use “I Am a Child of God” (*Children’s Songbook*, 2–3) to teach the children some basic details about the plan of salvation. The following outline is a suggestion:

Tell the children that we all lived with Heavenly Father before we were born.

Sing or say (invite children to join you):

I am a child of God,  
And he has sent me here.

Tell the children that Heavenly Father has a plan for us. He told us we would come to earth to live. We were so happy that we shouted for joy. Invite the children to say, “Hooray!”

Show the picture of a family on page 14. Tell the children that we came to earth to live with a family who loves us. Invite the children to cross their arms and hug themselves.

Sing or say:

Has given me an earthly home  
With parents kind and dear.

Tell the children that while we are on earth, Heavenly Father wants us to be happy and follow His commandments.

Sing or say:

Lead me, guide me, walk beside me,  
Help me find the way.

Show the picture of Jesus Christ on page 98. Tell the children that Heavenly Father chose Jesus Christ to help us return to Him. Explain that because of Jesus, we can live with Heavenly Father and with our families forever if we keep the commandments.

Sing or say:

Teach me all that I must do  
To live with him someday.



### TEACHING TIPS

**Preparation:** Prepare pictures, illustrations, and other materials before nursery begins. This will allow you to focus your attention on the children.

**Learning activities:** To engage the children and help them focus on the lesson, gather them close around you. If possible, kneel or sit so that you can look into their eyes. Hold the pictures close to them.

Sing the entire song, showing the pictures as you sing:  
I am a child of God,  
And he has sent me here,  
Has given me an earthly home (*show the picture of the family on page 14*)  
With parents kind and dear.  
Lead me, guide me, walk beside me,  
Help me find the way.  
Teach me all that I must do (*show the picture of Jesus on page 98*)  
To live with him someday.

**Conclusion** Share your testimony of Heavenly Father's plan for us.

**Prayer** Invite a child to give the closing prayer.

### OPTIONAL ACTIVITIES

**PREPARATION** *For the bag game:* Copy and cut out the illustrations on page 15. Bring something to hide the illustrations in, such as a small bag or cloth.

*For the coloring activity:* Copy page 15 for each child. Cut out the illustrations and the word strip. Bring string or yarn and tape to make mobiles for the children.

**Bag Game** Put the illustrations in the bag. Have a child choose a picture from the bag. Read or sing the caption and have the children repeat or sing the words with you. Repeat until each child who wants a turn has had one.

**Coloring** Let the children color a copy of the illustrations on page 15 and let them take them home to show their parents what they learned in nursery. If you have time, use the string or yarn and tape to make mobiles for the children as shown in the diagram at right.

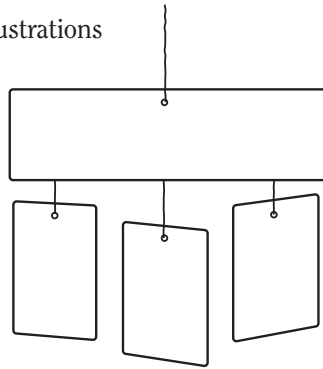

### TEACHING TIPS

**Resources:** Use only Church-produced resources in the nursery class (see *Teaching, No Greater Call*, 105). If you need more for the children to do, choose other stories, games, puppets, or coloring activities from this manual or from Church magazines. You can use these activities as often as you'd like, and you can teach a lesson two or three weeks in a row.

**Optional activities** are provided for you to add to your lesson if desired. If the supplies needed are not available to you, you may substitute similar supplies.

**Coloring:** While the children are coloring, review the principles taught in the lesson. Point out details in the pictures and explain to the children what they are coloring. Read the words on the illustration to them.



# Heavenly Father Has a Plan for Me

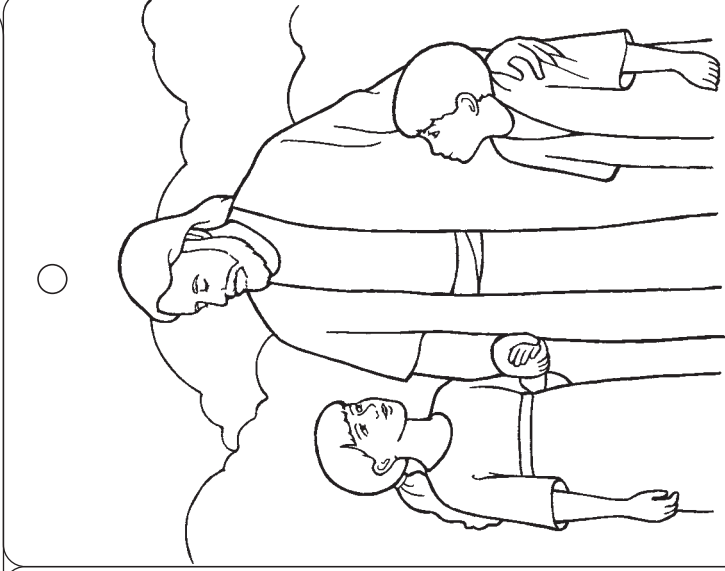

Teach me all that I must  
do to live with him  
someday.

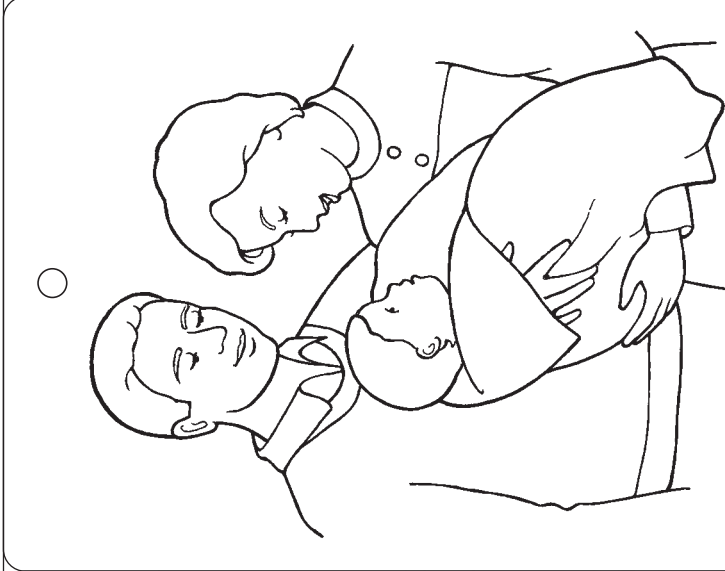

Has given me an earthly  
home, with parents kind  
and dear.

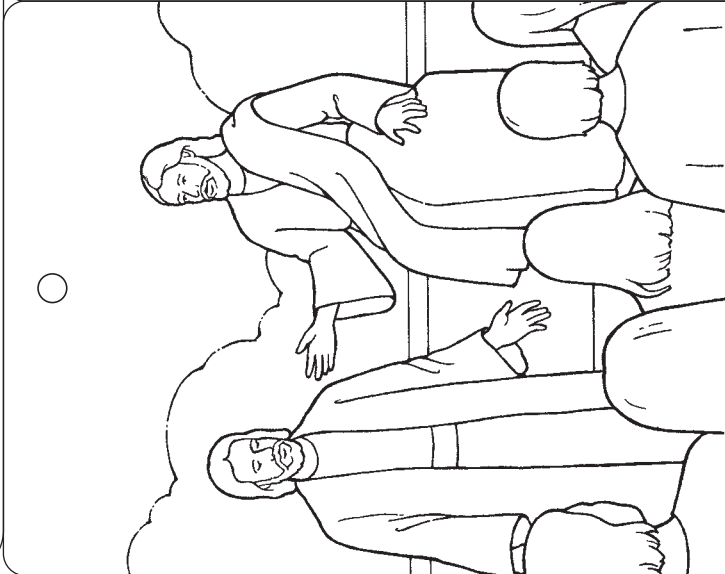

I am a child of God, and  
he has sent me here.

# 3

## I CAN PRAY TO HEAVENLY FATHER

### INTRODUCTION FOR THE TEACHER

To prepare yourself spiritually to teach this lesson, please read and ponder the following:

Through prayer we can talk with our Heavenly Father. We tell Him we love Him, we thank Him for blessings, and we ask for help for ourselves and for others in need. We end our prayers in the name of Jesus Christ. Prayer is one of the greatest blessings we have while we are here on earth. (See Matthew 6:9–13; Alma 34:18–27; 3 Nephi 18:19–21.)

### PREPARATION

- Bring a few small items or pictures that represent things we are thankful for (such as clothing, food, the scriptures, and so on) in a large bag. Write “We Thank Thee” on the bag. Bring another bag with items or pictures representing things we might ask for in a prayer (such as a happy family, strong bodies, love, and so on). Write “Please Bless Us” on this bag.
- Mark page 106 in this manual so that you can turn to it easily.

### LEARNING ACTIVITIES

Begin with a gathering activity. For ideas, see page 3.

**Prayer** Invite a child to give the opening prayer.

**Pictures** Show the picture of the boy Jesus praying (page 18). Tell the children that this is a picture of Jesus praying when He was a child. Show the picture of a child praying (page 18). Explain that when we pray we are talking to Heavenly Father; we begin by saying, “Our Heavenly Father.” Invite the children to say, “Our Heavenly Father.”

Tell the children that next we thank Him for our blessings. Have a child select an item from the bag labeled “We Thank Thee.” Say, “We thank Thee for our [name of item the child has selected].” Invite the children to say, “We thank Thee.” Repeat this activity until all the items are selected. Then tell the children that next we ask Heavenly Father for blessings, and repeat the activity with the bag labeled “Please Bless Us.” Invite the children to say, “Please bless us.”

Show the picture of Jesus on page 106. Tell the children that we end our prayers by saying, “In the name of Jesus Christ, amen.” Invite the children to say it with you.

**Activity Verse** Recite the following activity verse and invite the children to join you:  
I begin by saying “Dear Heavenly Father”; (*raise one finger—keep fingers raised throughout the activity verse*)  
I thank him for blessings he sends; (*raise second finger*)  
Then humbly I ask him for things that I need, (*raise third finger*)  
In the name of Jesus Christ, Amen. (*raise fourth finger*)  
[“I Pray in Faith,” *Children’s Songbook*, 14]

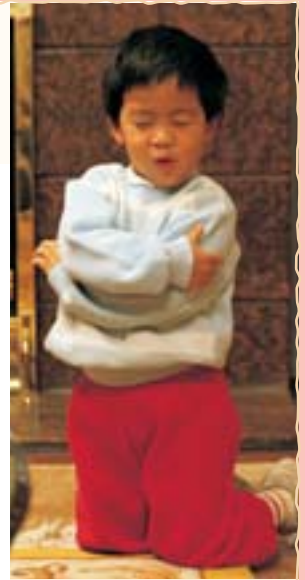

### TEACHING TIPS

**Prayer:** You can do much to help the children feel reverent as they prepare for prayer. For example, remind them to sit quietly and to fold their arms. You can also teach the language of prayer, helping them use respectful words such as *Thee*, *Thou*, *Thy*, and *Thine* in place of *you* and *your*. Until they learn to use their own words, you can prompt them as they pray.

**Inviting response:** Voice level, eye contact, and mannerisms are important when teaching. When asking for a response, look at the children, and in an encouraging voice say something like, “Can you say, ‘We thank Thee?’” Praise the children for participating.

**Conclusion** Remind the children that when they pray they are talking to Heavenly Father. Share your testimony that Heavenly Father hears our prayers.

**Prayer** Invite a child to give the closing prayer.

## OPTIONAL ACTIVITIES

**PREPARATION** *For the flip-book activity:* Copy the illustration on page 19. Color if desired. Make a flip book by cutting along the solid lines and folding along the dotted lines.

*For the scripture story:* Read Enos 1:1–8 and be prepared to summarize this story for the children. Bring a copy of the Book of Mormon. Mark Enos 1 so that you can turn to it easily.

*For the coloring activity:* Copy the illustration on page 19 for each child to color. Cut along the solid lines before nursery begins.

**Flip Book** Repeat the instructions on page 16

about what we say when we pray, this time using the flip book you have prepared. As you explain each part of prayer, lift the corresponding flap or invite a child to lift the flaps. You could also use the flip book while you recite the activity verse on page 16. You may want to keep the flip book to use during the nursery class in future weeks.

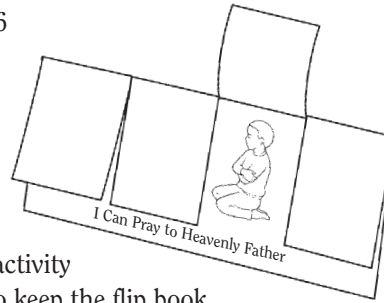

**Scripture Story** Open the Book of Mormon to Enos 1 and tell the children the story of Enos praying. Below is an example:

One day Enos went into the forest (*have the children hold up their arms and pretend to be trees*) to hunt animals (*have them pretend to shoot an arrow*). While he was in the forest, he prayed to Heavenly Father (*have the children kneel as if praying; finish the story while they are kneeling*). Heavenly Father answered his prayer, and Enos was happy. He knew Heavenly Father would bless him. Say, “I can pray to Heavenly Father.” Invite the children to repeat it with you, a few words at a time.

**Coloring** Let the children color a copy of the illustration on page 19. When they are finished, fold along the dotted lines.

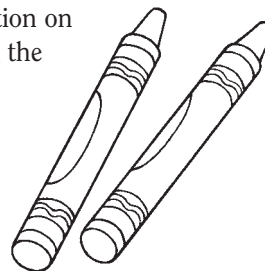

## TEACHING TIPS

**Testimony:** Express your testimony in a simple, concise way; for example: “I know that Heavenly Father hears our prayers.”

**Older children:** Consider inviting the older children to help you teach the younger children to pray. This is a great way to reinforce what you have taught.

**Stories:** When children act out events in a story, they understand it and remember it better. Remember that God the Father should not be portrayed when acting out a story. Do not portray Jesus Christ except in a nativity scene. (See *Teaching, No Greater Call*, 165–66.)

**Coloring:** While the children are coloring, review the principles taught in the lesson. Point out details in the pictures, and explain to the children what they are coloring. Read the words on the illustration to them.



I begin  
by saying,  
“Our  
Heavenly  
Father.”



I thank Him for  
blessings.

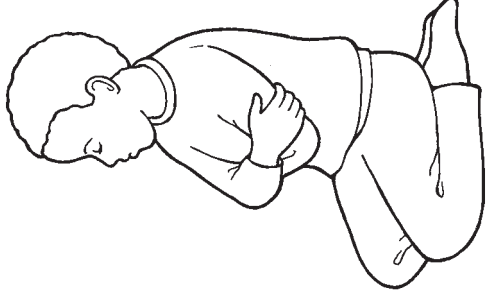

I ask Him for  
blessings.



In the name of  
Jesus Christ,  
amen.

I Can Pray to Heavenly Father



# 4

## HEAVENLY FATHER AND JESUS CHRIST LOVE ME

### INTRODUCTION FOR THE TEACHER

To prepare yourself spiritually to teach this lesson, please read and ponder the following:

Heavenly Father and Jesus Christ have perfect love for each of us individually. They loved us before we came to this earth; They continue to love us now; and Their great love for us will never change. During His earthly ministry, the Savior demonstrated great love for little children in particular (see Matthew 18:5, 10; Mark 10:13–16; 3 Nephi 17:11–24).

### PREPARATION

- Read 3 Nephi 17:11–12, 21–24 and be prepared to summarize this story briefly for the children.
- Bring a copy of the Book of Mormon.

### LEARNING ACTIVITIES

Begin with a gathering activity. For ideas, see page 3.

*Prayer* Invite a child to give the opening prayer.

*Doctrinal Instruction* Tell the children that you love them, and talk briefly about some other people who love them, such as their parents, brothers and sisters, grandparents, and so on. Then explain that there are two others who love them more than anyone—Heavenly Father and Jesus Christ. Tell the children, “Heavenly Father and Jesus know who you are. They know your name, and They love you.” Point to one of the children, and say, “Heavenly Father and Jesus love [child’s name].” Repeat for each child.

*Activity Verse* Recite the following activity verse and invite the children to join you:  
Heavenly Father knows me (*point to self*)  
And what I like to do.  
He knows my name and where I live. (*put fingertips together to form a housetop*)  
I know He loves me, too. (*hug self*)

*Scripture Story* Display the picture on page 22. Tell the children that we learn in the scriptures that Jesus loves little children. Open the Book of Mormon and briefly summarize the story of Jesus Christ blessing the Nephite children (3 Nephi 17:11–12, 21–24). Below is an example:  
Jesus was teaching the people (*point to Jesus in the picture*). He asked them to bring their little children to Him (*point to the children in the picture*). They sat on the ground around Him, and Jesus knelt and prayed (*have the children kneel and bow their heads*). Then He blessed each child, one by one. Jesus did this because He loves little children (*have the children hug themselves*).

*Song* Sing or say the following words to “I Feel My Savior’s Love” (*Children’s Songbook*, 74–75) and do the actions below. Invite the children to join you.  
I feel my Savior’s love (*place hands over heart*)  
In all the world around me. (*stretch arms out wide*) . . .



### TEACHING TIPS

*Introduction:* Studying the scriptures listed in the “Introduction for the Teacher” section is a good way to invite the Spirit in your lesson preparation (see *Teaching, No Greater Call*, 14).

*Actions:* You may want to take some time to talk about the actions that go with the songs or activity verses. For example, you could explain that when they put their fingertips together (line 3 of this activity verse) they make a shape that looks like a housetop, and that this action goes with the words “where I live.”

*Song:* If a song or activity verse is too long for the children in your nursery, use only part of it.

I feel my Savior's love, (*place hands over heart*)  
The love he freely gives me. (*point to self*)

**Conclusion** Share with the children your testimony that Heavenly Father and Jesus love each of them. Have the children repeat the phrase, "Heavenly Father and Jesus love me," a few words at a time.

**Prayer** Invite a child to give the closing prayer.

## OPTIONAL ACTIVITIES

**PREPARATION** *For the mirror activity:* Bring a small mirror that is large enough for the children to see their faces.

*For the picture activity:* Bring four or five pictures of things that Heavenly Father has blessed us with, such as a family, a home, trees, the scriptures, and so on. You can use pictures from Church magazines, copies of pictures from this book, or simple pictures you have drawn yourself.

*For the coloring activity:* Copy and cut out the illustration on page 23 for each child to color (one circle for each child). Thread yarn or a string through the top of each circle to make a necklace.

**Mirror Activity** Have the children sit in a circle. Move around inside the circle with the mirror, and let each child look at his or her face. As each child looks in the mirror, ask the child to say his or her name (if the child is able). Then say, "Heavenly Father and Jesus love [child's name]."

**Pictures** Place the pictures you have brought in various places throughout the room. Tell the children that Heavenly Father and Jesus Christ have given us many blessings because They love us. Invite them to walk with you to one of the pictures, and help them name the blessing it represents. Invite them to do an action associated with that blessing (pretend to read the scriptures, pretend to be a tree, and so on). Repeat for the other pictures.

**Activity Verse** Recite the activity verse on page 9.

**Coloring** Let the children color the necklaces you prepared for them. Read to them the words on the illustration.

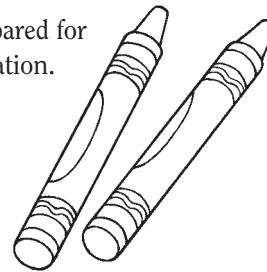

## TEACHING TIPS

**Testimony:** Bearing testimony invites the Spirit. Express your testimony in a simple, concise way; for example: "I know that Heavenly Father and Jesus love all of us."

**Young children:** To help young children stay attentive and participate in the activities, one nursery leader can give them extra help and attention while the other nursery leader is teaching.

**Previous lessons:** If you ever need more for the children to do, select activities from previous lessons. All or part of lessons may be taught more than once. The children enjoy repetition, and it is a good review.





# 5

## JESUS CHRIST SHOWED US HOW TO LOVE OTHERS

### INTRODUCTION FOR THE TEACHER

To prepare yourself spiritually to teach this lesson, please read and ponder the following:

Jesus Christ set a perfect example of kindness and love. Throughout His earthly ministry, Jesus showed His love for others by blessing and serving the poor, the sick, and the distressed. He told His disciples, “This is my commandment, That ye love one another, as I have loved you” (John 15:12; see also John 13:34–35; Moroni 7:46–48).

### PREPARATION

- Mark page 22 in this manual so that you can turn to it easily.
- Bring a copy of the scriptures.

### LEARNING ACTIVITIES

Begin with a gathering activity. For ideas, see page 3.

*Prayer* Invite a child to give the opening prayer.

*Song* Tell the children that when Jesus Christ lived on earth, He taught us to love others; He showed us how by the things He did. Sing or say the chorus of “I’m Trying to Be like Jesus” (*Children’s Songbook*, 78–79) and do the actions below. Invite the children to join you.

Love one another as Jesus loves you. (*hug self and turn from side to side*)

Try to show kindness in all that you do. (*nod head up and down*)

Be gentle and loving in deed and in thought, (*hug self and turn from side to side*)

For these are the things Jesus taught. (*nod head up and down*)

*Scripture Stories* Show the children a copy of the scriptures. Tell them that in the scriptures we learn how Jesus showed love. Briefly tell the following stories:

*Story 1* (show the illustration on page 27): Many people had come to hear Jesus teach. They were there a long time and got very hungry (*have the children pretend to be hungry*). There was only a little bread and fish to feed all of the people. Jesus blessed the food and told His disciples to give it to the people. Everyone had enough to eat, and there was a lot of food left over (*have the children pretend to eat*). (See Matthew 14:13–21.)

Have the children say with you, “Jesus showed us how to love others,” a few words at a time.

*Story 2* (show the picture on page 26): One day Jesus saw a man who was blind—he could not see (*have the children cover their eyes*). Jesus blessed the man so he could see (*have the children uncover their eyes*). (See John 9:1–12.)

Have the children say with you, “Jesus showed us how to love others.”

*Story 3* (show the picture on page 22): After Jesus was resurrected, He visited the Nephites. Because He loved the children, He blessed each one of them (*have the children hug themselves*). (See 3 Nephi 17:21–24.)



### TEACHING TIPS

*Songs:* Children love things that they have seen and heard before. Sing songs or do activity verses from this lesson or previous lessons at any time during the nursery class. This review will help them learn the songs and remember the gospel principles you have taught.

*Stories:* Before telling a story, read it several times to become familiar with it. As you tell the story, look the children in the eyes to help keep their attention. (See *Teaching, No Greater Call*, 181–82.)

*Young children* may not be able to repeat this phrase. Help them say key words like “Jesus” and “love.”

Have the children say with you, "Jesus showed us how to love others."

**Song** Sing or say the chorus of "I'm Trying to Be like Jesus" again. Invite the children to sing and do the actions with you.

**Conclusion** Share your testimony that we can love others as Jesus did.

**Prayer** Invite a child to give the closing prayer.

## OPTIONAL ACTIVITIES

**PREPARATION** *For the puzzle:* Bring a picture of the Savior (you could use the picture on page 106 if you'd like). Find a piece of paper that is the same size as the picture (or cut a piece of paper to the same size) and cut the paper into three or four pieces to make a puzzle. Write "I Will Love Others" on the back of each piece.

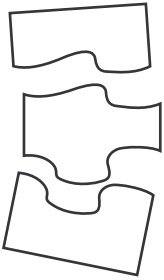

*For the scripture activity:* Bring a copy of the Bible. Mark John 15:12 so that you can turn to it easily.

*For the illustration activity:* Copy the illustration on page 27 for each child.

**Puzzle** Cover the picture of Jesus with the puzzle pieces. Ask a child to choose a piece. Read the phrase on the piece and have all the children repeat it. Discuss one way we can love others (say thank you, share, do what Mother or Father ask, put toys away, and so on). Repeat with each piece until the illustration is completely uncovered. Reinforce the concept that Jesus showed us how to love others.

**Scripture** Tell the children that in the scriptures Jesus taught us to love one another. Open the Bible to John 15:12 and read, "Love one another." Invite the children to repeat the phrase with you.

**Song** Sing or say the words to "Jesus Said Love Everyone" (*Children's Songbook*, 61) and do the actions below. Invite the children to join you.

Jesus said love everyone; (*spread arms out wide*)  
Treat them kindly too. (*nod head up and down*)  
When your heart is filled with love, (*put hand over heart*)  
Others will love you. (*hug self*)

**Illustration** Give each child a copy of the illustration on page 27. Ask the children questions about the illustration to remind them of the story you told them earlier. For example:

Can you see Jesus in the picture? (*have the children point to Jesus on their copies of the illustration*)  
What is in the baskets? (*have the children pretend to eat*)

## TEACHING TIPS

**Optional activities:** To maintain active participation and learning, alternate listening with activities that involve movement. Keep the length of each activity to about two or three minutes.

**Repetition:** Nursery-age children enjoy repetition, and it helps them learn. If children are still interested and paying attention, repeat activities so that each child has a chance to participate.



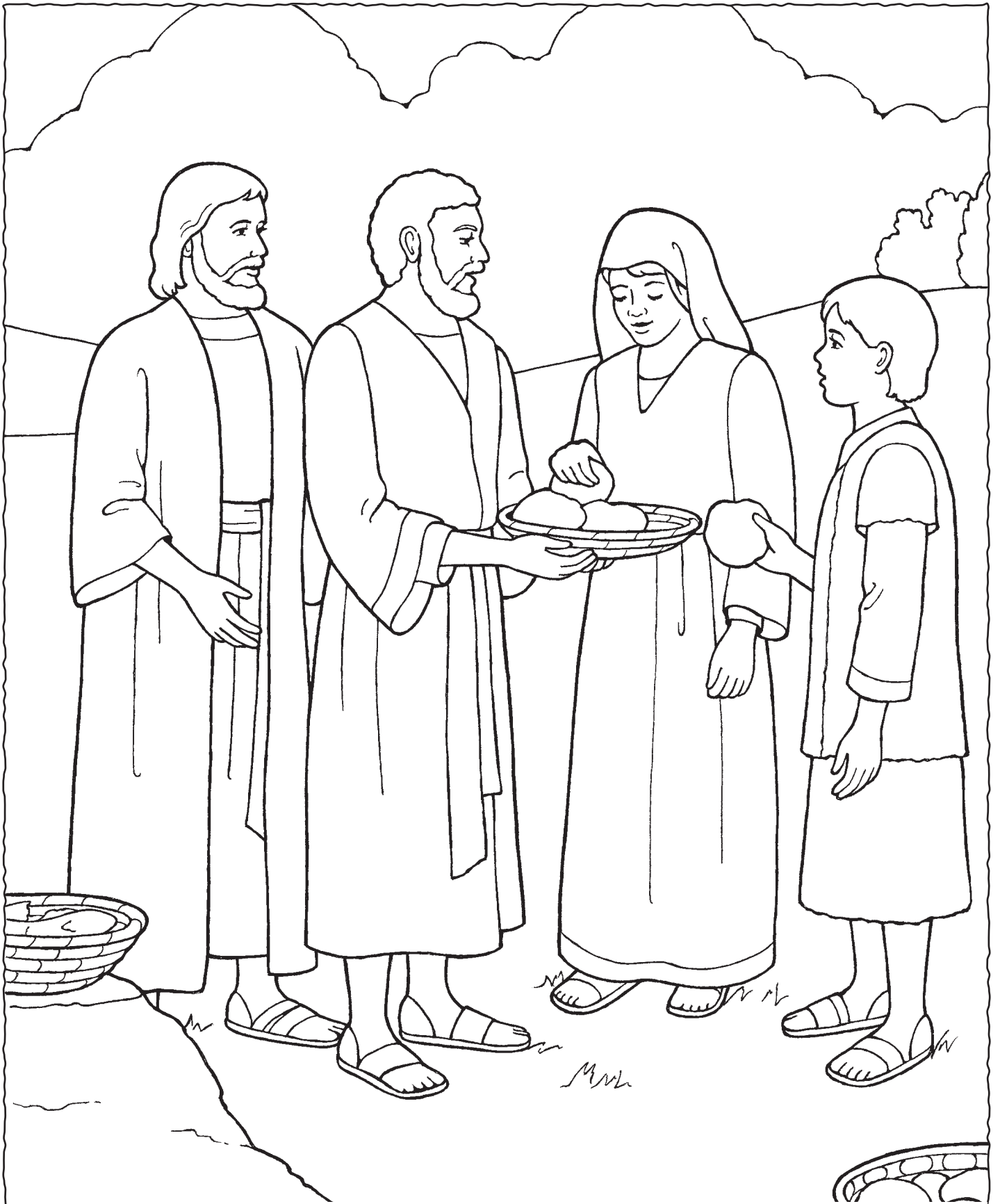

Jesus Christ Showed Us How to Love Others



# 6

## THE HOLY GHOST HELPS ME

### INTRODUCTION FOR THE TEACHER

To prepare yourself spiritually to teach this lesson, please read and ponder the following:

The Holy Ghost is a member of the Godhead, along with Heavenly Father and Jesus Christ. He is a personage of spirit (see D&C 130:22). The mission of the Holy Ghost is to testify of the Father and the Son and of the truth of all things (see 3 Nephi 11:36; Moroni 10:5). He can also guide us to make righteous choices and comfort us (see D&C 31:11). The way the Holy Ghost speaks to us is described in the scriptures as a “still small voice” (see 1 Kings 19:11–12).

### LEARNING ACTIVITIES

Begin with a gathering activity. For ideas, see page 3.

**Prayer** Invite a child to give the opening prayer.

**Song** Tell the children that you are going to sing a song about Heavenly Father. Sing or say the words to the first verse of “I Know My Father Lives” (*Children’s Songbook*, 5) and do the actions below. Invite the children to join you.

I know my Father lives and loves me too. (*touch hand to chest*)

The Spirit whispers this to me and tells me it is true, (*cup hand to ear*)

And tells me it is true.

**Repetition Activity** Invite the children to say “Spirit.” Tell them that another name for the Spirit of God is the Holy Ghost. Invite the children to say “Holy Ghost.” Explain that the Holy Ghost helps us know that Heavenly Father loves us.

**Role Play** Tell the children that when we do what is right, the Holy Ghost helps us know we made a good choice. Invite the children to join you as you role-play doing things that are right. For example:

It’s the right thing to go to church. Let’s pretend to walk to church (*swing arms as you walk in a circle*).

Repeat with other examples, such as sharing a toy, helping Mother sweep the floor, and so on.

**Story** Explain that the Holy Ghost can also help us when we are afraid. Tell the following story:

One day there was a bad storm outside David’s house. There was loud thunder (*have children cover their ears*) and lots of wind (*have children blow to mimic the wind*) and rain (*have children mimic the rain with their fingers*). David was afraid. His mother told him that when she is afraid she prays to Heavenly Father (*show the picture on page 30*). David and his mother prayed that Heavenly Father would keep them safe. Then David felt safe and happy. His mother said that Heavenly Father had sent the Holy Ghost to give him those feelings so he wouldn’t be afraid.

Invite the children to say “Holy Ghost.”



### TEACHING TIPS

**Holy Ghost:** Even at a young age, children can learn to recognize the influence of the Holy Ghost. During any lesson, help them recognize the feelings of love and warmth that come from the Holy Ghost—particularly when they are learning about Heavenly Father and Jesus Christ.

**Young children:** Remember that most children have difficulty focusing their attention for long periods of time. Watch for signs that they need a change. If they have been sitting for a while, do an activity that allows them to move their bodies.

**Conclusion** Share your testimony of the Holy Ghost. This could include a simple, brief experience from your own life when you were guided by the Holy Ghost.

**Prayer** Invite a child to give the closing prayer.

## OPTIONAL ACTIVITIES

**PREPARATION** *For the scripture activity:* Bring a copy of the Bible. Mark John 14:26 so that you can turn to it easily.

*For the illustration activity:* Copy the illustration on page 31 for each child.

*For the cube game:* Copy the illustration on page 31 and color it if desired. Cut along the solid lines and fold along the dotted lines. Tape or glue the tabs to make a cube.

**Activity Verse** Form a circle with the children and recite the following activity verse:  
The Holy Ghost speaks softly. (*put finger to lips*)  
He never shouts, it's true. (*cup hands around mouth as if shouting*)  
He'll bless and help and guide you (*join hands and walk in a circle*)  
In everything you do. (*sit down*)

**Scripture** Tell the children that Jesus taught in the scriptures that the Holy Ghost will teach us. Open the Bible to John 14:26 and read, "The Holy Ghost . . . shall teach you all things." Invite the children to repeat the phrase with you, a few words at a time.

**Illustration** Display the illustration on page 31 and give each child a copy of the illustration. Point to the picture of the Church building and explain that the Holy Ghost helps us know that going to church is the right thing to do. Invite the children to point to the Church building on their copies. Repeat for the other illustrations.

**Cube Game** Roll the cube you made. Read the caption on the top of the cube, and have the children repeat it with you. Then have the children do some simple actions to go with the picture. When the side with the words "The Holy Ghost Helps Me" comes up, tell the children that the Holy Ghost helps us know when we've done something good. Repeat, giving each child a turn to roll the cube.

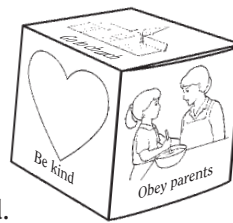

## TEACHING TIPS

### **Personal experiences:**

Relating personal experiences can help those you teach see how the gospel influences our daily lives (see *Teaching, No Greater Call*, 45, 180). For this age-group, the experience you share will need to be very simple and brief—no more than a sentence or two.

**Scriptures:** "When you teach children, you should use the scriptures frequently and find ways to have the children become comfortable using the scriptures" (*Teaching, No Greater Call*, 59). You can help them develop a love for the scriptures even before they are able to read. Even if you read only a short part of the verse to the children, read the entire verse during your preparation for the lesson.

**Taking turns** is difficult for young children. If you have many children in your nursery class, you may want to roll the cube yourself each time rather than having the children take turns.



The Holy Ghost  
Helps Me

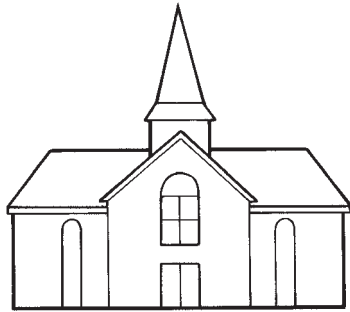

Go to church

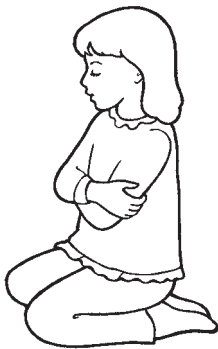

Pray

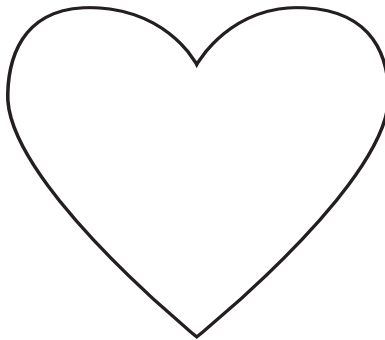

Be kind



Obey parents

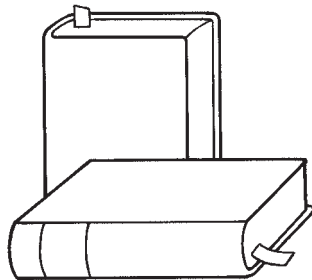

Read scriptures

# 7

## JESUS CHRIST CREATED THE WORLD FOR ME

### INTRODUCTION FOR THE TEACHER

To prepare yourself spiritually to teach this lesson, please read and ponder the following:

Working under the direction of Heavenly Father, Jesus Christ created the beautiful world we live in (see Moses 2:1). The purpose of the creation of the earth was to give us a place where we could be tested and gain experiences in order to become more like our Heavenly Father (see Abraham 3:24–25). The wonderful beauties of the earth bear witness of the power and great love of Heavenly Father and Jesus Christ (see Moses 6:63).

### PREPARATION

Bring a copy of the Bible. Mark Genesis 1:1 so that you can turn to it easily.

### LEARNING ACTIVITIES

Begin with a gathering activity. For ideas, see page 3.

*Prayer* Invite a child to give the opening prayer.

*Song* Sing or say the words to “My Heavenly Father Loves Me” (*Children’s Songbook*, 228–29) and do the actions below. Invite the children to join you.

Whenever I hear the song of a bird (*cup hand to ear*)

Or look at the blue, blue sky, (*look up, pretending to shade eyes with hand*)

Whenever I feel the rain on my face (*touch fingertips to face*)

Or the wind as it rushes by, (*wave hands back and forth*)

Whenever I touch a velvet rose (*cup hands together*)

Or walk by our lilac tree, (*use two fingers to “walk” up other arm*)

I’m glad that I live in this beautiful world (*raise hands in circle above head*)

Heavenly Father created for me. (*point to self*)

*Scripture* Open the Bible to Genesis 1:1 and read, “In the beginning God created the heaven and the earth.” Invite the children to repeat the scripture with you, a few words at a time. Explain that Heavenly Father had Jesus Christ make the world and everything in it; Jesus also made the sun to give us light. Invite the children to raise their hands above their heads in a circle and say “sun.”

Tell the children that Jesus made the stars we see at night. Invite the children to open and close their hands like stars twinkling and say “stars.”

*Picture* Show the picture on page 34. Point to the trees and tell the children that Jesus made the plants. Invite the children to stand and stretch their arms high, pretending to be trees blowing in the wind. Invite them to say “trees.”

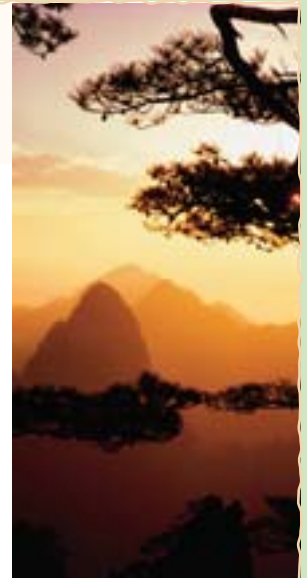

### TEACHING TIPS

*Songs:* “Most children enjoy participating in musical activities. The appealing rhythms of music help children remember . . . the messages of the words. Music can increase children’s understanding of gospel principles and strengthen their testimonies” (*Teaching, No Greater Call*, 174).

*Young children:* If the children get restless before you have finished all of the learning activities, it is all right to stop the lesson and do an activity that lets the children move around, such as walking, swaying, or moving their arms. As children get older, they will be able to focus for longer periods of time.

Point to the animals in the picture and explain that Jesus made the animals. Invite the children to name some of the animals and make some animal sounds.

**Conclusion** Explain that Jesus made all these things because He loves us. Express your gratitude for our beautiful world.

**Prayer** Invite a child to give the closing prayer.

## OPTIONAL ACTIVITIES

**PREPARATION** *For the seed activity:* Bring a plastic cup for each child. Also bring some soil to put in the cups and bring some seeds (such as bean, corn, or wheat seeds) for each child to plant. On each cup write, “Jesus Christ Made Seeds for Me.” Prepare a note to send home with the children explaining how to care for the seed.

*For the book activity:* Make a copy of page 35 for each child to color. Bring some tape or glue.

**Song** Sing or say the words to “The World Is So Lovely” (*Children’s Songbook*, 233) and do the actions below. Invite the children to join you.

The world is so lovely! I’m glad as can be (*push corners of mouth into a smile*)

For all that the Lord has created for me— (*point to self*)

The sunshine, (*raise arms in circle above head*)

the flowers, (*pretend to smell a flower*)

the stars up above, (*open and close hands like twinkling stars*)

A home where I live, and a family I love. (*hug self*)

**Seed Activity** Put some soil in each of the cups you brought and let each child plant a seed. While they are doing this, tell them that if they water their seeds and put them where they will get plenty of sunlight, the seeds will grow into plants. Remind them that Jesus Christ made the seeds, the soil, the rain, and the sunshine. Let the parents take their children’s cups home so they can watch their seeds grow. This activity is most appropriate for older children.

**Book** Let the children color a copy of the illustration on page 35. While they are coloring, review the things you taught in the lesson. When they are finished, fold the illustration and tape or glue it according to the instructions on the illustration. Then read the book with the children.

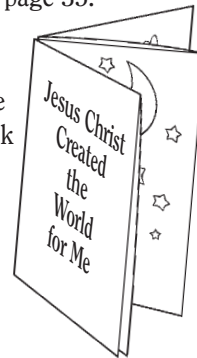

## TEACHING TIPS

**Seed activity:** If you choose to do this activity, keep the cups of soil in a safe place until it is time for the children to go home. If your nursery meets before sacrament meeting, don’t let the children take the cups of soil into the chapel. Instead, give the cups to the parents after sacrament meeting.

**Book:** Consider making an activity box to keep in the nursery. It can contain the book you made for this lesson and other things you make or use for other activities. Then you can repeat those activities during future nursery classes to review previous lessons. This review can happen at any time during the nursery class.

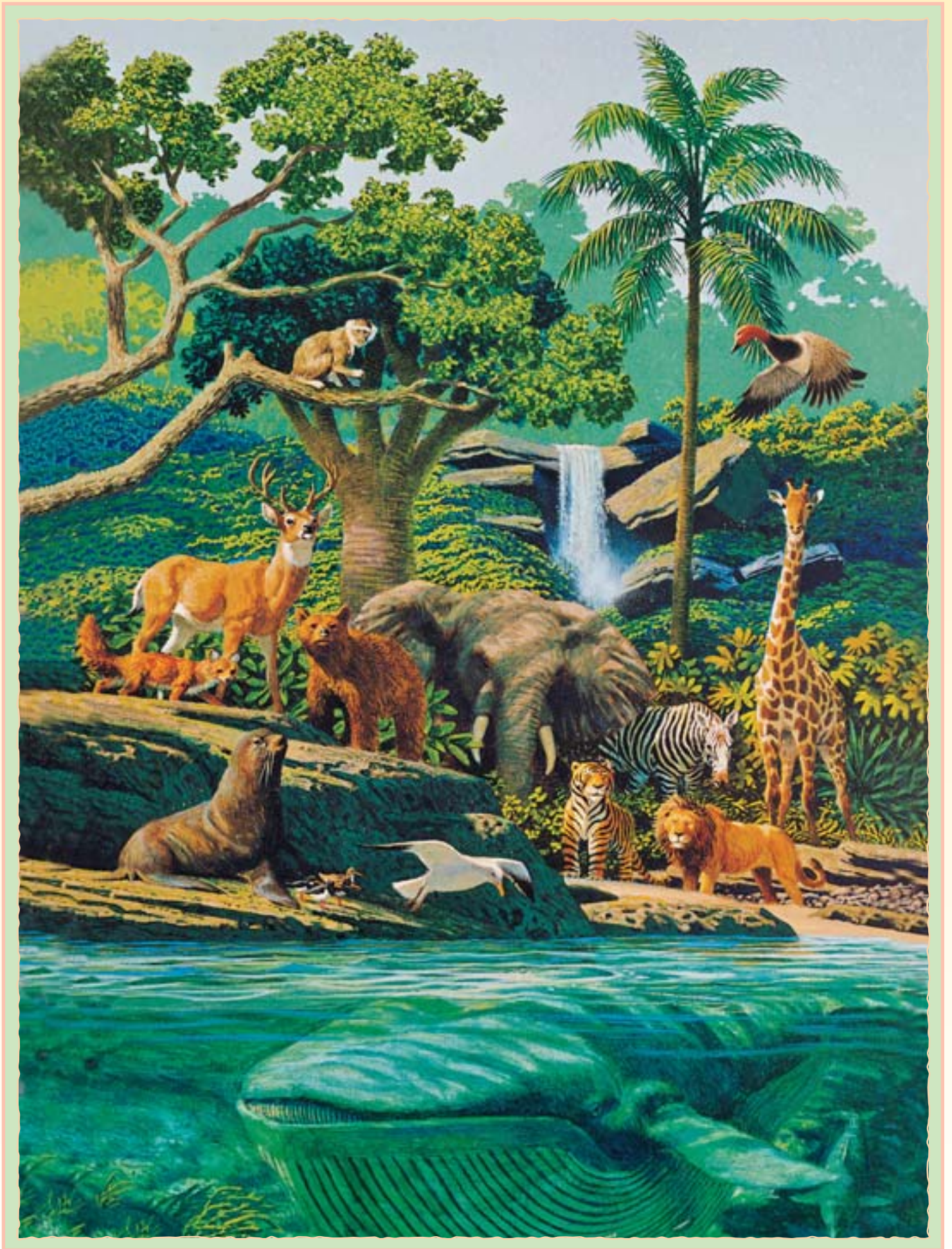

Jesus Christ  
Created  
the  
World  
for Me

3. Fold along this line ↓

5. Fold along this line ↓

4. Put tape or  
glue on this  
panel

2. Fold along this line ↑

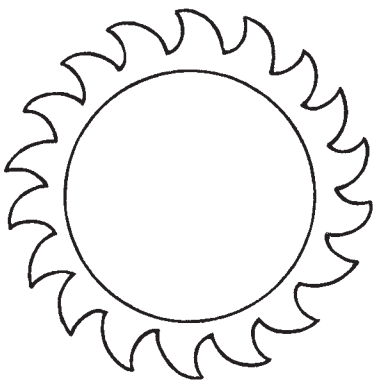

Jesus created the sun.

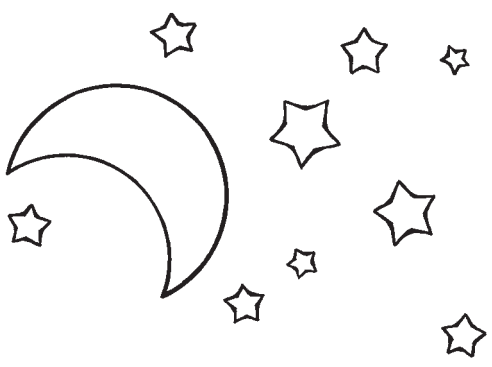

He created the moon  
and the stars.

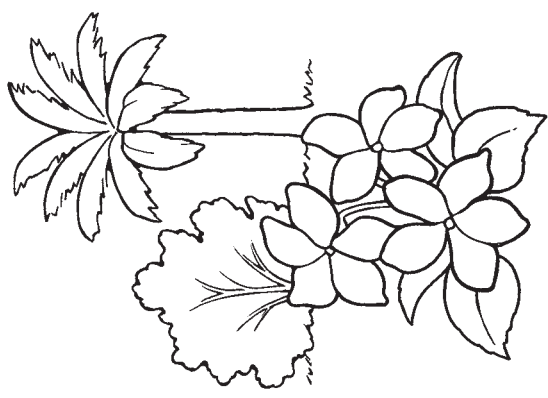

He created the plants.

1. Fold in half along this line ↑

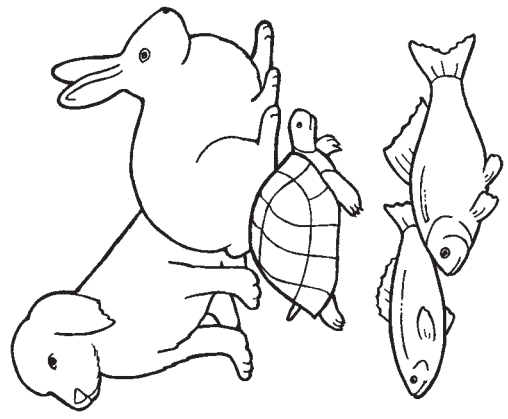

He created the animals.

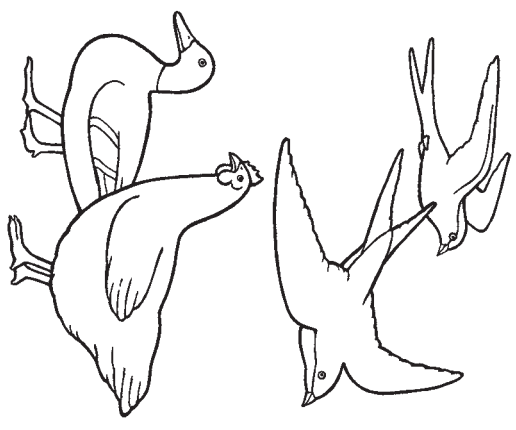

He created the birds.



# 8

## SUNDAY IS A DAY TO REMEMBER HEAVENLY FATHER AND JESUS CHRIST

### INTRODUCTION FOR THE TEACHER

To prepare yourself spiritually to teach this lesson, please read and ponder the following:

Since Old Testament times, God’s people have set apart one day in seven as the Sabbath day—a day to rest from our labors and worship God (see Genesis 2:2–3; Exodus 20:8–11). The Lord has repeated this commandment in our day, and He has promised that keeping the Sabbath day holy will help us remain “unspotted from the world” (see D&C 59:9–10).

### LEARNING ACTIVITIES

Begin with a gathering activity. For ideas, see page 3.

**Prayer** Invite a child to give the opening prayer.

**Picture** Show the picture of the family walking to church on page 38 and tell the children that this family is going to church on Sunday. Explain that Sunday is a special day and that we go to church on Sunday to worship Heavenly Father and Jesus Christ and learn about Them.

**Songs** Tell the children, “Let’s pretend we’re going to church.” Have them walk in a circle and sing or say the following words to “Fun to Do” (*Children’s Songbook*, 253):

Going to church is fun to do,  
Fun to do, to do, to do!  
Going to church is fun to do,  
To do, to do, to do!

Have the children sit down, and tell them that when we come to church we remember (*point to your head*) and think about (*point to your head again*) Heavenly Father and Jesus. Sing or say the first line of “Reverently, Quietly” (*Children’s Songbook*, 26):

Reverently, quietly, lovingly we think of thee.

Show the picture of the family at home on page 38. Point out the different family members and explain that after church, in our homes, we can remember Heavenly Father and Jesus with our families. We can read the scriptures together (*have the children pretend to read the scriptures*) and pray together (*have the children fold their arms*) and show love for each other (*have the children put their hands on their heart*). Sing or say the words to “A Happy Family” (*Children’s Songbook*, 198). Invite the children to join you.

I love mother; she loves me.  
We love daddy, yes sirree;  
He loves us, and so you see,  
We are a happy family.

**Conclusion** Remind the children that Sunday is a day to remember Heavenly Father and Jesus at church and at home with our families. Invite the children to say, “Sunday.”



### TEACHING TIPS

**Songs:** As you prepare to teach, try to memorize the words to songs and activity verses. This will allow you to focus on the children and their learning. (See *Teaching, No Greater Call*, 159.)

**Songs:** Consider making a list of the songs the children are learning, especially the songs they love to sing. Sing them throughout the nursery class each week, while the children are playing with toys, before or after snack time, or while the children are waiting for their parents. This is a good way to review previous lessons. Even if the children do not sing with you at first, they are listening and learning.

*Prayer* Invite a child to give the closing prayer.

## OPTIONAL ACTIVITIES

**PREPARATION** *For the bag game:* Make a copy of page 39. Cut out the illustrations and color them, if desired. Put the illustrations in a bag or other container.

*For the scripture activity:* Bring a copy of the Bible. Mark Genesis 2:2 so that you can turn to it easily. Also mark page 34 in this manual.

*For the book activity:* Copy the illustration on page 39 for each child to color.

**Bag Game** Invite a child to choose a picture from the bag. Read the caption and invite the children to do an action suggested by the picture (such as walking in place for “On Sunday I can go to church” or pointing to their heads for “Sunday is a day to remember Heavenly Father and Jesus Christ”). Invite the children to say key words from each caption, such as “Jesus,” “scriptures,” “family,” and “church.” Repeat with each picture or until each child who wants a turn has had one.

**Scripture** Show the picture on page 34 and review the story of the Creation with the children (see Genesis 1 and lesson 7 in this manual). Explain that Jesus worked for six days to make the world.

Tell the children that you are going to read a scripture that tells us what Jesus did on the seventh day. Open the Bible to Genesis 2:2 and read, “He rested on the seventh day from all his work which he had made.” Emphasize the word *rested* as you read.

Ask: “What did Jesus do on the seventh day?”

Answer: “He rested.”

Tell the children that on six days of the week we work. Invite them to act out different kinds of work, such as sweeping the floor, digging in the garden, and so on. Explain that on Sunday we rest. Invite the children to sit down, and tell them how thankful you are that Heavenly Father gave us a day to rest from our work.

**Book** Let the children color a copy of page 39. While they are coloring, talk to them about the illustrations and remind them that these are things we do to remember and worship Heavenly Father and Jesus Christ on Sunday. When they are finished coloring, fold along the dotted lines to make a book. Then read the book to the children.

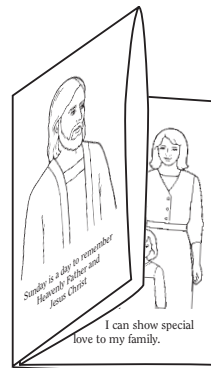

## TEACHING TIPS

**Bag game:** If you don't have a bag or other container, you could place the illustrations face-down and let a child choose one to turn over.

**Taking turns** can be difficult for children. Having them sit on a chair or on the floor while they're waiting for their turn can help. You can also have one of the nursery leaders focus on helping them wait while the other nursery leader is teaching.

**Book:** Encourage the children to show their books to their families. This will give their parents an opportunity to review with the children the things they have learned. (See *Teaching, No Greater Call*, 167.)



On Sunday I can show special  
love to my family.

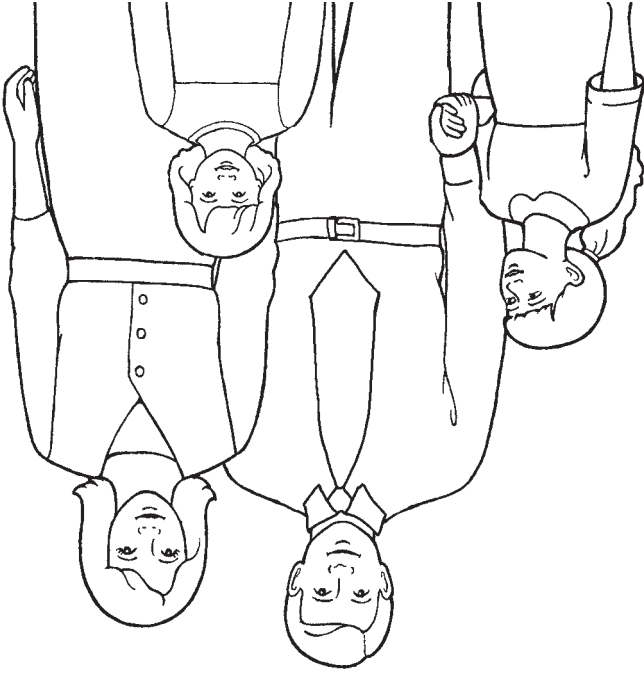

On Sunday I can go  
to church.

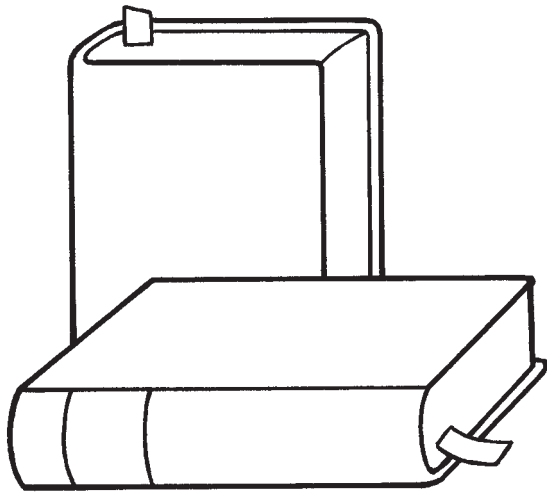
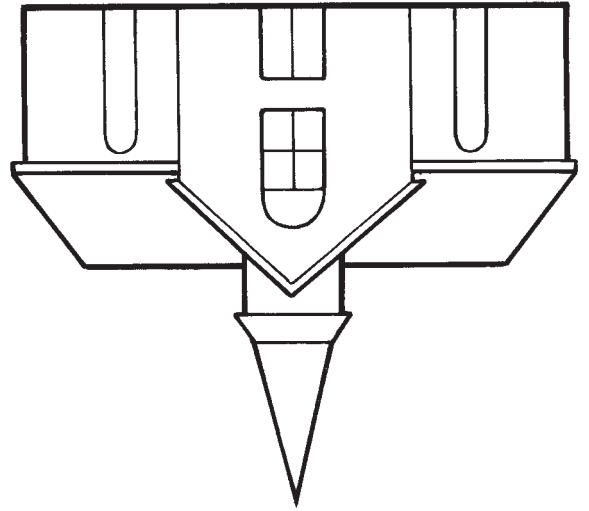

On Sunday I can read  
the scriptures.



Sunday is a day to remember  
Heavenly Father and  
Jesus Christ.

# 9

## I HAVE A BODY LIKE HEAVENLY FATHER'S

### INTRODUCTION FOR THE TEACHER

To prepare yourself spiritually to teach this lesson, please read and ponder the following:

Each of us is a child of God. The scriptures teach that “God created man in his own image” (Genesis 1:27; see also Moses 2:26–27; Abraham 4:26–27). This means that our bodies are similar to His. The Prophet Joseph Smith saw Heavenly Father and Jesus Christ, and he taught that “the Father has a body of flesh and bones as tangible as man’s; the Son also” (D&C 130:22).

### LEARNING ACTIVITIES

Begin with a gathering activity. For ideas, see page 3.

**Prayer** Invite a child to give the opening prayer.

**Song** Sing the first verse of “I Am a Child of God” (*Children’s Songbook*, 2):  
 I am a child of God,  
 And he has sent me here,  
 Has given me an earthly home  
 With parents kind and dear.

Repeat, and invite the children to listen or sing with you. Tell them that when we say “God” we mean Heavenly Father.

**Scripture Story** Show the picture on page 42. Briefly tell the story of Joseph Smith’s First Vision to teach the children that Heavenly Father has a body like ours (see Joseph Smith—History 1:17). Below is an example:

When Joseph Smith was a boy (*point to Joseph in the picture*), he prayed to Heavenly Father. Something wonderful happened. Joseph saw Heavenly Father and Jesus Christ (*point to Heavenly Father and Jesus in the picture*). They came and spoke to Joseph. Joseph saw that Heavenly Father has a body like we do. Heavenly Father has arms. Do you have arms? Show me your arms. Heavenly Father has hands. Do you have hands? Show me your hands. Heavenly Father has a face. Do you have a face? Touch your face. You are a real person. Heavenly Father is a real person. He created your body. You have a body like Heavenly Father’s.

**Activity Verse** Invite the children to stand and do the following activity verse with you:

I have a special body  
 Heavenly Father gave to me. (*touch hands to chest*)  
 He gave me ears so I might hear (*cup hand around ear*)  
 And eyes that I might see. (*point to eyes*)  
 He gave me hands so I can clap, (*clap hands*)  
 Two feet that turn around. (*turn around*)  
 And when I want, I touch my toes (*bend over and touch toes*)  
 Way down upon the ground.  
 When I think about my body, (*put finger to head*)  
 The best part of it is  
 That Heavenly Father planned it  
 To look very much like His. (*sit down quietly*)



### TEACHING TIPS

**Learning activities:** Monitor the children’s involvement during the activities. You know the capabilities and needs of the children in your nursery. Adapt the activities as needed. (See *Teaching, No Greater Call*, 33–34.)

**Activity verses:** You can use activity verses at any time during the nursery class, whenever the children need to move around, or when you need to engage their attention. They are also a good way to review principles you have taught previously.

*Conclusion* Invite the children to repeat after you, a few words at a time, “I have a body like Heavenly Father’s.” Express your gratitude for your body.

*Prayer* Invite a child to give the closing prayer.

## OPTIONAL ACTIVITIES

*PREPARATION* *For the finger-puppet story:* Copy, color, and cut out the finger puppets on page 91.

*For the tracing activity:* Bring a blank piece of paper for each child and something to write with.

*For the illustration activity:* Copy the illustration on page 43 for each child.

*Song* Sing or say the words to “Head, Shoulders, Knees, and Toes” (*Children’s Songbook*, 275) and point to each body part as you say it. Invite the children to join you.

Head, shoulders, knees, and toes, knees and toes, knees and toes,

Head, shoulders, knees, and toes, eyes, ears, mouth, and nose.

Repeat as often as the children would like. Remind them that Heavenly Father gave us bodies that look like His.

*Finger-Puppet Story* Retell the story of the First Vision, using the finger puppets you have made (see Joseph Smith—History 1:11–17; see also the example on page 88). Emphasize the fact that Joseph Smith saw that Heavenly Father and Jesus Christ have bodies like ours.

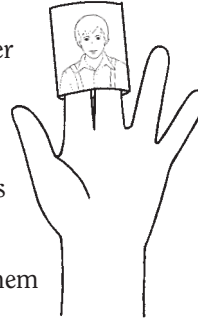

*Tracing* Trace each child’s hand on a piece of paper. Let them color the tracings. Write on the paper the child’s name and age and the date.

*Illustration* Display the illustration on page 43 and give each child a copy. Point to the boy’s face and remind the children that we have faces and so does Heavenly Father. Invite the children to point to the face on their copy of the illustration. Repeat for other body parts. Let the children color their illustrations, if desired.

## TEACHING TIPS

*Finger puppets:* When you make finger puppets or other teaching aids for a nursery lesson, keep them. You might be able to use them again for future lessons.

*Review:* Repeat activities from previous lessons as often as you would like. Repetition is fun for the children, and it helps them learn.



# I Have a Body like Heavenly Father's

I have a face like  
Heavenly Father.



I have two hands like  
Heavenly Father.

I have two feet like  
Heavenly Father.



# 10

## I WILL TAKE CARE OF MY BODY

### INTRODUCTION FOR THE TEACHER

To prepare yourself spiritually to teach this lesson, please read and ponder the following:

One of the great blessings of the plan of salvation is the opportunity to receive a physical body. The Lord wants us to respect our bodies and take good care of them. He blesses us when we do so (see 1 Corinthians 3:16; D&C 89:18–21).

### LEARNING ACTIVITIES

Begin with a gathering activity. For ideas, see page 3.

**Prayer** Invite a child to give the opening prayer.

**Picture** Tell the children that Heavenly Father gave us our bodies and with our bodies we can do many wonderful things. Show the picture on page 46. Point out each family member in the picture; when you point to the baby, ask questions similar to those listed below. After each question, invite the children to respond with you by saying “No” as you turn your head from side to side in an exaggerated way.

- Can a baby walk?
- Can a baby talk?
- Can a baby throw a ball?

Tell the children they were once babies, but now they are growing bigger.

**Song** Have the children stand. Sing or say the following words to the tune of “Once There Was a Snowman” (*Children’s Songbook*, 249) and do the actions below. Invite the children to join you.

Once I was a baby, baby, baby. (*pretend to rock baby in arms*)  
Once I was a baby, small, small, small. (*gradually crouch down*)  
Now I’m growing bigger, bigger, bigger. (*gradually stand up*)  
Now I’m growing bigger, tall, tall, tall! (*stretch hands above head*)

**Picture** Show the picture again and point to the young child playing with her father. Tell the children that this child is about their size. Ask the children questions similar to those listed below. After each question, invite the children to respond with you by saying “Yes” as you nod your head in an exaggerated way.

- Can you walk? (*have the children walk in place*)
- Can you talk? (*count to five with the children*)
- Can you throw a ball? (*have the children pretend to throw a ball and catch it*)

Tell the children they are growing bigger because they eat good foods, go to bed and sleep, and wash themselves to keep clean.

**Role Play** Show the illustration on page 47. Point to the picture of the girl sleeping and explain that sleeping is one way to take care of our bodies. Invite the children to pretend to sleep. Repeat for the other pictures in the illustration.



### TEACHING TIPS

**Note:** During this lesson, be sensitive to the feelings of any children in your nursery who have physical disabilities. You may need to change the questions you ask during the picture activities. Focus on the things the children *can* do, not what they cannot do. For more information about teaching those with disabilities, see *Teaching, No Greater Call*, 38–39.

**Role play:** Young children may not know how to do some of the actions suggested in the role-play activity. As an alternative, you can invite them to point to their different body parts. For example, point to your mouth and say, “This is my mouth. Can you show me your mouth?” Clap your hands and praise the children. Repeat for other body parts.

*Conclusion* Express your gratitude for the bodies Heavenly Father gave us. Invite the children to say, “I will take care of my body,” a few words at a time.

*Prayer* Invite a child to give the closing prayer.

## OPTIONAL ACTIVITIES

*PREPARATION* *For the guessing game:* Bring three or four healthy foods, such as fruits and vegetables, on a plate. Bring something to cover the plate of food, such as a large cloth.

*For the coloring activity:* Copy the illustration on page 47 for each child to color.

*Guessing Game* Show the children the plate with food. Point to each item, and help the children name them. Cover the food with the cloth; then take away one of the items and remove the cloth. Invite the children to guess which one is missing. This activity is most effective for older children.

*Activity Verse* Recite the following activity verse and invite the children to join you:  
This little fellow is going to bed. (*raise one finger*)  
Down on the pillow he lays his head. (*lay finger on palm of other hand*)  
Wraps himself in the blankets tight, (*close hand over finger*)  
And this is the way he sleeps all night.  
Morning comes and he opens his eyes.  
Back with a toss the cover flies. (*open hand to show finger resting*)  
Soon he is up and dressed and away, (*raise finger up*)  
Ready to smile and work and play.

*Coloring* Let the children color a copy of the illustration on page 47. While they are coloring, point out that the illustration shows ways we can take care of our bodies.

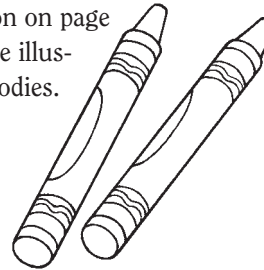

## TEACHING TIPS

*Optional activities* allow you to meet the needs of the children in your nursery. You can choose to do any or all of them, and you can repeat them as often as you like. Choose activities that the children will enjoy and that will help them learn. Feel free to adapt them to your circumstances and needs.

*Coloring:* Not all children enjoy coloring. Some may only make a mark or two on the page. They can still learn from the illustrations, even if they don't spend much time coloring them.



# I Will Take Care of My Body

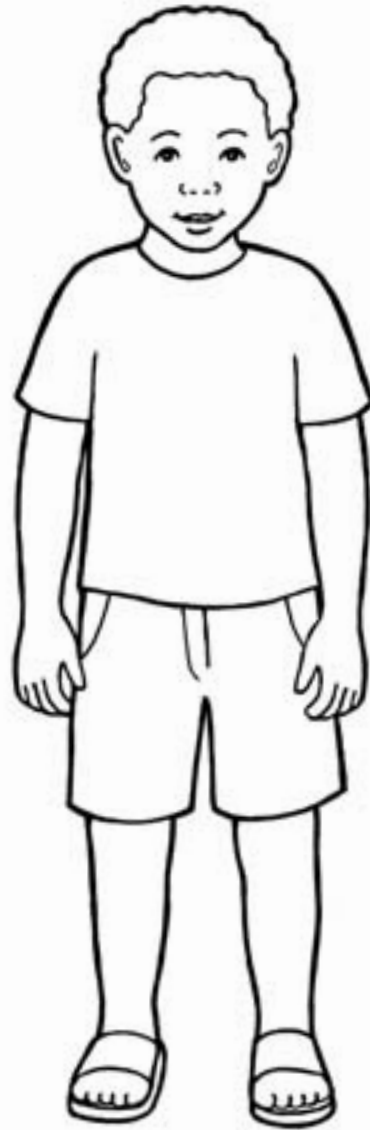
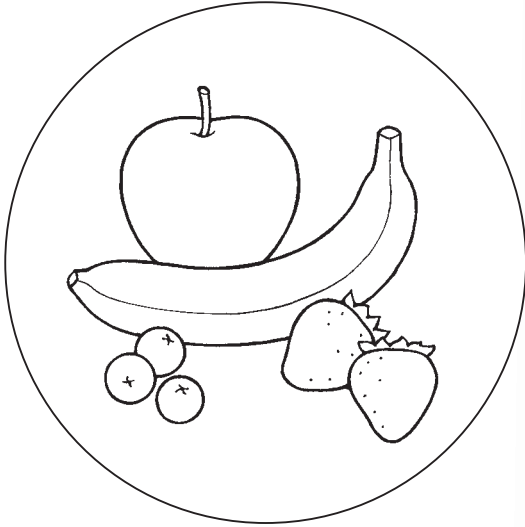

# 11

## I LOVE MY FAMILY

### INTRODUCTION FOR THE TEACHER

To prepare yourself spiritually to teach this lesson, please read and ponder the following:

The family is central to the plan of salvation. Heavenly Father has established families to bring us happiness and prepare us for eternal life. In a family we can learn correct principles in a loving atmosphere. It is important that family members love and care for each other. We show our love by being helpful and respectful (see Ephesians 6:1–3). The scriptures teach us to be “kind one to another [and] tenderhearted” (Ephesians 4:32; see also “The Family: A Proclamation to the World,” *Ensign*, Nov. 1995, 102).

### PREPARATION

Trace or make a copy of the family figures on page 51. Color them, if desired. Cut them out and place them in a container.

### LEARNING ACTIVITIES

Begin with a gathering activity. For ideas, see page 3.

**Prayer** Invite a child to give the opening prayer.

**Picture** Show the picture of a happy family on page 50. Tell the children that Heavenly Father has given each of us a family. Explain that our families love us and we can show our love for our family by being kind and helpful.

**Role Play** Hold the container and ask a child to choose a family figure. Tell the children what member of the family it is (mother, father, brother, sister, or baby), and have the children repeat it with you. Suggest a way they can show love for that family member (by picking up toys, sharing, smiling, and so on). Invite them to pretend to do the action. Repeat this activity with each family figure.

**Song** Sing or say the words to “A Happy Family” (*Children’s Songbook*, 198) and do the actions below. Invite the children to join you.

I love mother; she loves me. (*place hand on chest*)  
We love daddy, yes sirree; (*nod head up and down*)  
He loves us, and so you see, (*extend arms*)  
We are a happy family. (*hug self*)

I love sister; she loves me. (*place hand on chest*)  
We love brother, yes sirree; (*nod head up and down*)  
He loves us, and so you see, (*extend arms*)  
We are a happy family. (*hug self*)

**Conclusion** Encourage the children to be loving and kind to their family members. Invite them to say, “I love my family.”

**Prayer** Invite a child to give the closing prayer.



### TEACHING TIPS

**Figures:** If you don’t have access to a copy machine, place a plain sheet of paper over the figures and trace them with a pencil or pen. Don’t worry about tracing all of the details; just trace the outlines and enough detail to identify the figures.

Keep these figures to use in future lessons (such as lesson 13). You can also use them to review this lesson at any time during any nursery class.

**Note:** During this lesson, be sensitive to the home and family situations of the children.

## OPTIONAL ACTIVITIES

**PREPARATION** *For the story:* Mark page 18 in this manual so that you can turn to it easily.

*For the poster:* Ask the parents of each nursery child for a small photograph showing the child with his or her family (they may have already provided this photograph when the child first joined the nursery class; see page 7). Attach the photographs to a poster board. At the top, write “I Love My Family.”

**Story** Show the children the picture of Jesus and His mother (page 18). Point to Jesus and tell the children that this is a picture of Jesus when He was a child. Point to Mary and say that this is Jesus’s mother. Explain that Jesus had a loving family who took good care of Him when He was small, and He loved His family very much. Suggest ways the children can show love for their mothers (by smiling, helping clean up, giving a hug, and so on). Invite them to pretend to do those things.

**Song** Add new words to the song “Fun to Do” (*Children’s Songbook*, 253) to teach the children some ways they can show love for their families. For example, say to the children, “Let’s show how we can love Sister.” Sing “Sharing a toy is fun to do” and do simple actions. Other words you can use are, “Picking up toys is fun to do,” “Cleaning the room is fun to do,” “Giving a smile is fun to do,” “Helping my dad is fun to do,” and so on.

**Poster** Display the poster you have prepared. Point to a picture and say, “This is [child’s name]’s family. Here is [child’s name].” Repeat for each child. Emphasize that we all have families who love us and we love them. Display the poster each week and allow the children to respond to questions about their family (“Where is [child’s name]’s family?” “Where is [child’s name]?” “Where is Daddy?” and so on). Add pictures to the poster as other children join the nursery.

## TEACHING TIPS

**Preparation:** The preparations you make before nursery starts will allow you to focus your attention on the children when they arrive. Greet them with a smile. (See *Teaching, No Greater Call*, 79.)

**Repetition:** One of the most important teaching methods for nursery-age children is repetition. Children like to hear the same songs and stories over and over. Use the same words each time.



# I Love My Family

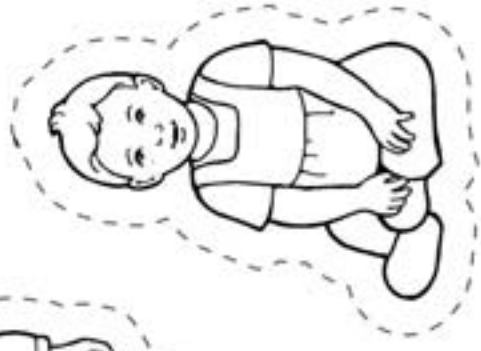
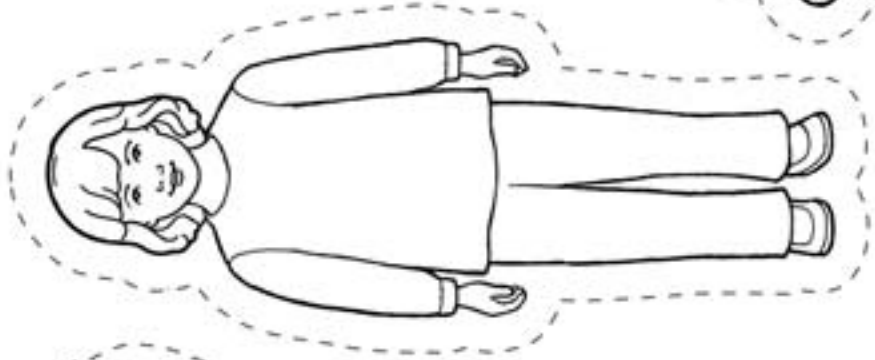
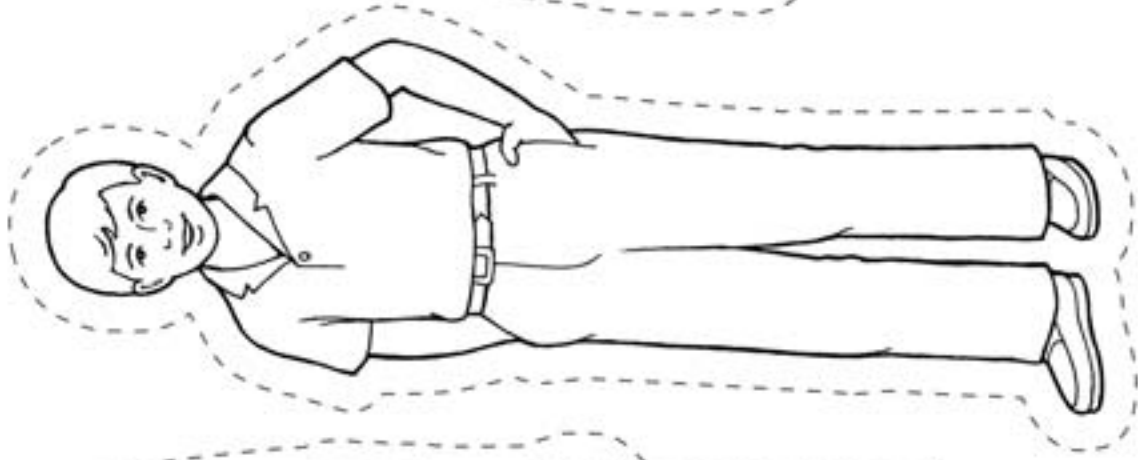
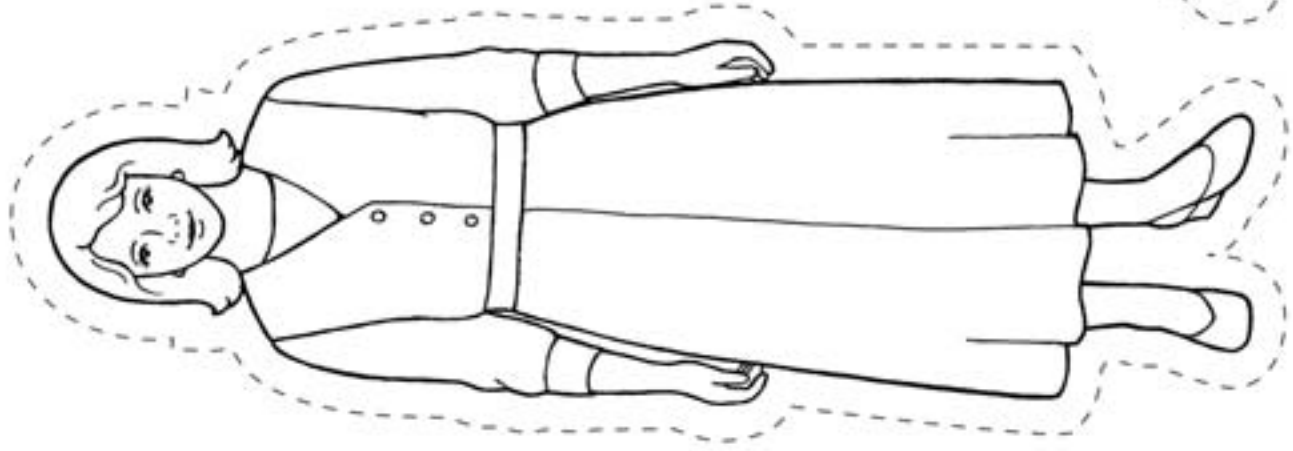
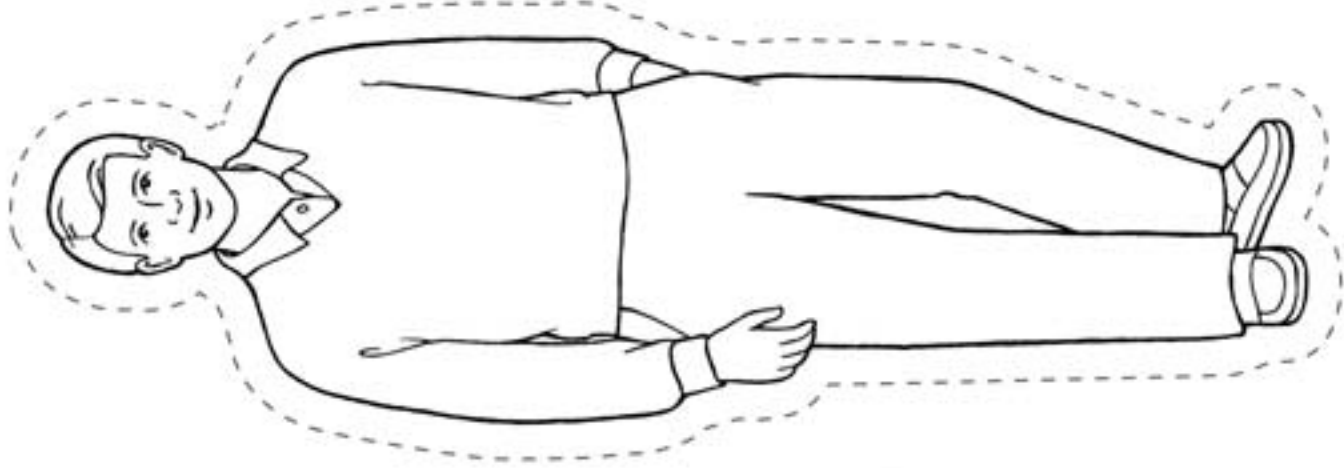



# 12

## I CAN PRAY WITH MY FAMILY

### INTRODUCTION FOR THE TEACHER

To prepare yourself spiritually to teach this lesson, please read and ponder the following:

The Savior said, “Pray in your families unto the Father, always in my name, that your [families] may be blessed” (3 Nephi 18:21). By praying together, families can grow closer to Heavenly Father and to each other and invite the Holy Ghost in the home (see D&C 19:38).

### PREPARATION

- Mark page 106 in this manual so that you can turn to it easily.
- Bring a copy of the Book of Mormon. Mark 3 Nephi 18:21 so that you can turn to it easily.

### LEARNING ACTIVITIES

Begin with a gathering activity. For ideas, see page 3.

**Prayer** Invite a child to give the opening prayer.

**Song** Invite the children to say the words “family prayer” a few times. Tell them you are going to learn a song about family prayer. Form a circle with the children, and have everyone hold hands. Sing or say the words to “Family Prayer” (*Children’s Songbook*, 189) and help the children do the actions with you:

Let us gather in a circle (*walk around in a circle*)

And kneel in family prayer (*stop walking and kneel; have the children repeat “family prayer” after you*)

To thank our Heavenly Father (*fold arms*)

For the blessings we all share.

**Picture** Show the picture of a family praying (page 54). Help the children identify the different members of the family, and point out that they are kneeling and that their arms are folded, their heads are bowed, and their eyes are closed. Tell them that this family is having family prayer. Invite the children to say the words “family prayer.” Invite them to kneel, fold their arms, and bow their heads. Explain that when we have family prayer, we talk to Heavenly Father. We thank Him for our blessings, and we ask Him to help and bless our family.

**Activity Verse** Recite the following activity verse and invite the children to join you:  
This is my mother, who helps me at play. (*raise thumb*)  
This is my father, who works all the day. (*raise second finger*)  
This is my brother, so strong and so tall. (*raise third finger*)  
This is my sister, who likes to play ball. (*raise fourth finger*)  
And this is me; I’m happy to say (*raise fifth finger*)  
Together our family kneels down to pray. (*close fist*)

**Scripture** Display the picture of Jesus Christ on page 106. Open the Book of Mormon to 3 Nephi 18:21 and say, “Jesus said, ‘Pray in your families.’ ” Invite the children to repeat this sentence with you, a few words at a time.



### TEACHING TIPS

**Songs:** To teach a song or an activity verse, memorize the words and actions yourself beforehand. As you sing or recite the words, emphasize each word and each action. You can add simple, appropriate actions to any song or verse to help keep the children focused and to enhance learning. (See *Teaching, No Greater Call*, 159.)

**Young children** have short attention spans. If the children get restless before you finish all of the activities, you can stop the lesson to let the children get up and move and then come back to the lesson later.

**Scriptures:** Use the scriptures as you teach the children and as you prepare to teach. This invites the Spirit, and it helps the children develop a love for the word of God. Show them that what you are teaching them comes from the scriptures.

**Conclusion** Invite the children to say, “I can pray with my family,” a few words at a time.

**Prayer** Invite a child to give the closing prayer.

## OPTIONAL ACTIVITIES

**PREPARATION** *For the finger-puppet story:* Copy and cut out the finger puppets on page 59. Color them if desired.

*For the bag game:* On four small bags write “We Are Thankful for Our Blessings.” In each bag place a picture of something we are thankful for (such as food, clothing, a house, a family, and so on). If you’d like, you can use copies of the illustrations on page 55 or elsewhere in this manual.

*For the coloring activity:* Copy the illustration on page 55 for each child to color. Bring scissors and tape.

**Finger-Puppet Story** Use the finger puppets to tell the following story about a family prayer:

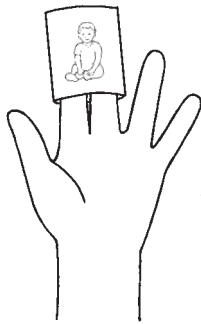

Here is a family. This is the father, and this is the mother. Here are the sister and the brother. This is Peter, the little brother (*point to the puppet of the baby*). One day Peter was playing and hurt his eye (*invite the children to cover their eye with their hand*). Father and Mother took him to see the doctor (*take the puppet off the finger and lay it on the floor*). Peter’s family knelt in family prayer (*invite the children to kneel*). They asked Heavenly Father to bless Peter. Heavenly Father heard their prayer. He helped Peter get better (*put the puppet back on the finger*). Then Peter and his family had family prayer again to thank Heavenly Father for blessing Peter.

**Bag Game** Place the bags on the floor. Have everyone hold hands, form a circle around the bags, and walk in a circle as you sing “Family Prayer.” Then stop walking, and let a child choose a bag and show the picture inside. Say, “We are thankful for [name of item pictured].” Praise the children for their participation. Repeat until every child who wants a turn has had one.

**Coloring** Let the children color a copy of page 55. When they are finished, cut out the strips, and link them together with tape to make a chain for each child to take home.

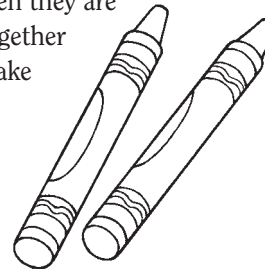

## TEACHING TIPS

**Puppets:** “Puppets can be used to dramatize parts of a lesson or story, welcome children to class, give instructions, sing songs, help with role playing, ask questions, or help children remain attentive” (*Teaching, No Greater Call*, 176–77).

**Bag game:** If you don’t have bags or sacks, you could place the pictures face-down and let a child choose one to turn over.

**Note:** Please keep scissors and other potentially dangerous objects out of the children’s sight and reach.



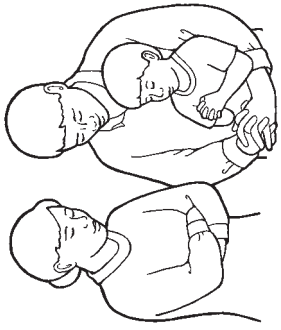

I Can Pray with My Family

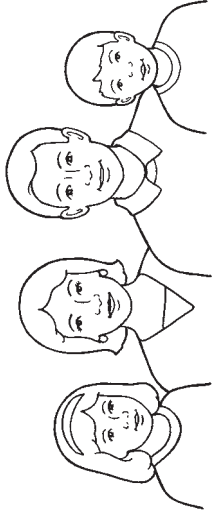

We are thankful for our family.

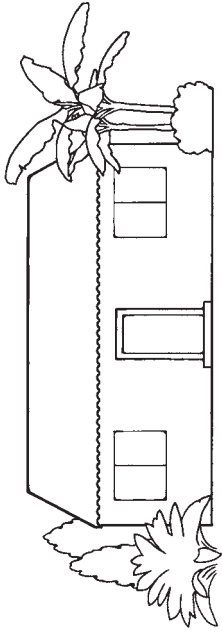

We are thankful for our home.

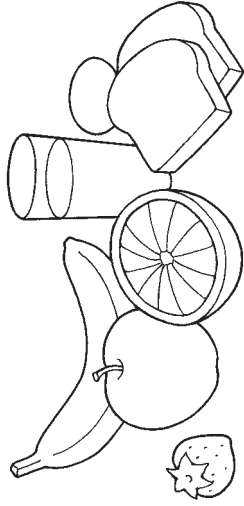

We are thankful for food to eat.

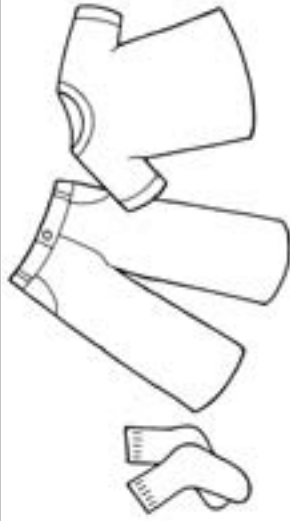

We are thankful for our clothes.

# 13

## MY FAMILY CAN BE TOGETHER FOREVER

### INTRODUCTION FOR THE TEACHER

To prepare yourself spiritually to teach this lesson, please read and ponder the following:

Heavenly Father has made it possible for family relationships to continue after this life. If family members are sealed in the temple and faithfully keep the commandments, they can be united as a family eternally and live in Heavenly Father's presence. (See Matthew 16:19; D&C 138:47–48.)

### PREPARATION

If possible, bring a picture of a temple in your area.

### LEARNING ACTIVITIES

Begin with a gathering activity. For ideas, see page 3.

**Prayer** Invite a child to give the opening prayer.

**Picture** Show a picture of a temple in your area (or show the picture on page 58). Tell the children that this is a picture of a temple. Describe the picture for them, pointing out the spire, windows, doors, and so on. Ask them to repeat the word “temple” a few times. Have them pretend to be a beautiful temple by putting their hands together above their heads to make a temple spire.

**Song** Invite the children to stand. Sing or say the words to “I Love to See the Temple” (*Children's Songbook*, 95) and do the actions below. Invite the children to join you.

I love to see the temple. (*put fingertips together to form a spire*)  
I'm going there someday (*walk in place*)  
To feel the Holy Spirit, (*put hand over heart*)  
To listen and to pray. (*fold arms*)

Tell the children that the temple is the house of the Lord. Invite them to say, “House of the Lord.” Emphasize that the temple is a very special place; because of the temple, our families can be together forever.

**Activity Verse** Recite the following activity verse and invite the children to join you:

This is Mother. (*hold up hand; point to thumb*)  
This is Father. (*point to index finger*)  
This is Brother tall. (*point to middle finger*)  
This is Sister. (*point to ring finger*)  
This is Baby. (*point to little finger*)  
Oh, how we love them all. (*hold both hands to chest*)

**Song** Sing or say the first two lines of the chorus of “Families Can Be Together Forever” (*Children's Songbook*, 188):  
Families can be together forever  
Through heavenly Father's plan.  
Invite the children to repeat these lines with you several times slowly.

**Conclusion** Briefly share your feelings about the temple. Share your testimony that families can be together forever.



### TEACHING TIPS

**Note:** Be sensitive to the family and home situations of the children during this lesson.

**Songs:** Consider making a list of songs the children enjoy singing, and sing them each week at various times during the nursery class. For example, you could sing while the children are playing with toys, before or after snack, or while the children are waiting for their parents. This is a good way to review previous lessons.

**Conclusion:** This conclusion can be very brief; for example: “I love the temple! I know that families can be together forever.”

*Prayer* Invite a child to give the closing prayer.

## OPTIONAL ACTIVITIES

**PREPARATION** *For the activity verse:* Copy and cut out the finger puppets on page 59 or use the puppets you made for the optional activity in lesson 12. Color the puppets if desired.

*For the guessing game:* Copy and cut out the family figures on page 51 or use the figures you prepared for lesson 11. Bring something to cover the figures, such as a blanket or cloth. If possible, bring a picture of a temple in your area.

*For the coloring activity:* Copy and cut out the circles on page 59 for each child. Thread yarn or a string through the top of the two circles to make a necklace.

**Finger Activity** Tell the children that we must prepare to go to the temple. Ask them to hold up five fingers, and help them list on their fingers five things they can do to prepare to go to the temple when they are older (pray, obey parents, love others, go to church, follow the prophet, and so on). This activity is especially appropriate for older children.

**Activity Verse** Repeat the activity verse on page 56, this time using the finger puppets.

**Guessing Game** Place the family figures on the floor next to the picture of the temple (one you have brought or the one on page 58). Cover the figures with a blanket or cloth. Take away one of the puppets. Remove the cloth and ask the children to guess who is missing. Then put the missing figure back in place and tell the children that Heavenly Father wants all families to be together forever, with no one missing. This activity is especially appropriate for older children.

**Coloring** Invite the children to color the necklaces you prepared. While they are coloring, reinforce the principle that because of the temple, families can be together forever.

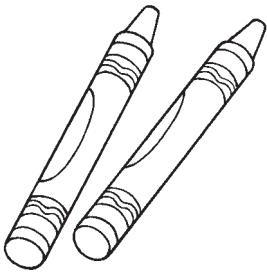

## TEACHING TIPS

**Finger puppets:** It's a good idea to save the illustrations, finger puppets, games, and other items you prepare for these lessons. You can use them in future lessons or at any time during the nursery class to review principles you have taught previously.

**Coloring:** Encourage the children to show their necklaces to their families. This can help them remember what they learned, and it gives their parents an opportunity to discuss the principles of the lesson with them. (See *Teaching, No Greater Call*, 167.)





Copy this page and cut out the finger puppets on the solid, straight lines. Fold on the dotted lines. Then tape the sides, leaving the bottom edges open so the children can put the puppets on their fingers.

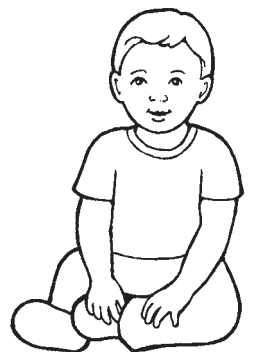
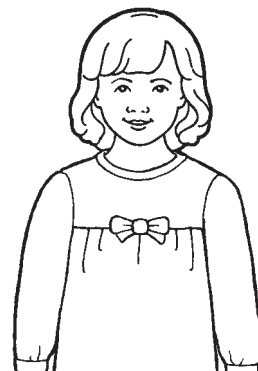
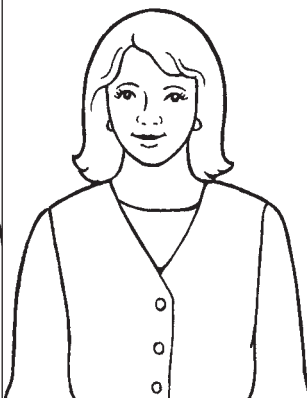
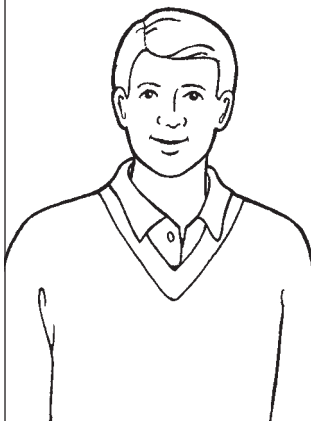



# 14

## I WILL OBEY

### INTRODUCTION FOR THE TEACHER

To prepare yourself spiritually to teach this lesson, please read and ponder the following:

Heavenly Father has given parents the primary responsibility for teaching their children the commandments, providing for their physical and spiritual needs, and protecting them from harm. He encourages us to honor and obey our parents, and He blesses us with safety and happiness when we do so. (See Exodus 20:12; Ephesians 6:1–3; Colossians 3:20; “The Family: A Proclamation to the World,” *Ensign*, Nov. 1995, 102.)

### PREPARATION

- Bring a copy of the Bible. Mark Ephesians 6:1 so that you can turn to it easily.
- Mark page 106 in this manual so that you can turn to it easily.

### LEARNING ACTIVITIES

Begin with a gathering activity. For ideas, see page 3.

*Prayer* Invite a child to give the opening prayer.

*Actions* Ask the children to do five or six actions, such as stand up, raise their hands, turn around, clap their hands, and sit down. Praise them for obeying you.

*Picture* Have a child hold the picture on page 62. Point out the father and mother in the picture. Explain that the father and mother have asked the children to help in the garden, and the children said, “I will obey.” Point out the children in the picture and emphasize that they are helping their parents.

*Scripture* Tell the children that in the scriptures we learn that Heavenly Father and Jesus Christ want us to obey our parents. Open the Bible to Ephesians 6:1 and read, “Children, obey your parents in the Lord: for this is right.” Invite the children to say, “I will obey.” (*Note:* It may be that some of the children are being raised by grandparents or other relatives. Be sensitive to such circumstances during this lesson.)

*Song* Invite the children to stand. Sing or say the words to “Quickly I’ll Obey” (*Children’s Songbook*, 197) and do the actions below. Invite the children to join you.

When my mother calls me, (*cup hands around mouth*)  
Quickly I’ll obey. (*run quietly in place*)  
I want to do just what is best (*nod head up and down*)  
Each and every day.

When my father calls me, (*cup hands around mouth*)  
Quickly I’ll obey. (*run quietly in place*)  
I want to do just what is best (*nod head up and down*)  
Each and every day.



### TEACHING TIPS

*Love:* Strive to love the children in the nursery. “When we love those we teach, we pray for each of them. . . . We tailor our teaching to meet their needs, even if this takes more time and effort. We notice when they are absent and recognize them when they are present. We offer help when it is needed” (*Teaching, No Greater Call*, 32).

Heavenly Father loves me, (*hug self*)  
Blesses me each day. (*continue hugging self as you turn from side to side*)  
I want to do just what is best (*nod head up and down*)  
Each and every day.

**Picture** Show the picture of Jesus on page 106. Tell the children that Jesus obeyed Heavenly Father, and He wants us to obey too.

**Conclusion** Share your testimony that we will be happy if we obey.

**Prayer** Invite a child to give the closing prayer.

### OPTIONAL ACTIVITIES

**PREPARATION** *For the object activity:* Bring a box, basket, or other container with a few items inside that give protection, such as an umbrella, shoes, a hat, a coat, or gloves. Try to have at least one item for each child to hold.

*For the puppet activity:* Copy and cut out the illustration on page 63 for each child to color. Glue or tape them to sticks or paper sacks to make puppets.

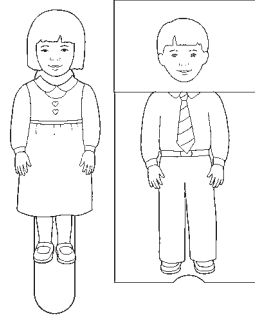

**Role Play** Say and do the following with the children:  
Mommy says, "Get dressed, please." Let's get dressed (*pretend to get dressed*).  
Daddy says, "Wash your face, please." Let's wash our faces (*pretend to wash face*).  
Repeat with other actions, such as "eat your breakfast," "go to sleep," and so forth. Praise the children for obeying.

**Object Activity** Ask a child to choose one of the items out of the box and try it on. Talk to the children about what kind of protection that item gives (for example, shoes keep our feet from getting dirty or hurt; umbrellas keep us from getting wet from the rain or hot from the sun; and so on). Explain that these things keep us safe; we can also be safe and happy when we obey our parents.

**Puppet Activity** Let the children color the puppets you prepared. Read the following scenarios (or create some of your own). After each one, have the children use their puppets to answer, "I will obey."  
Mommy says, "Be kind to your sister, please." What will you say?  
Daddy says, "Time to go to bed, please." What will you say?  
Grandmother says, "Come to dinner, please." What will you say?  
Teacher says, "Let's get ready for prayer, please." What will you say?  
Jesus says, "Love one another." What will you say?  
This activity is especially appropriate for older children.

### TEACHING TIPS

**Prayer:** If the child needs help praying, prompt him or her with short, simple phrases to repeat. The older children may be able to pray using their own words.

**Praise** is important to children. They are loving and want to be loved and accepted. Build their confidence and show your love for them by sincerely praising their efforts whenever possible.

**Review:** As the children leave the nursery class, help them explain to their parents what they have learned.

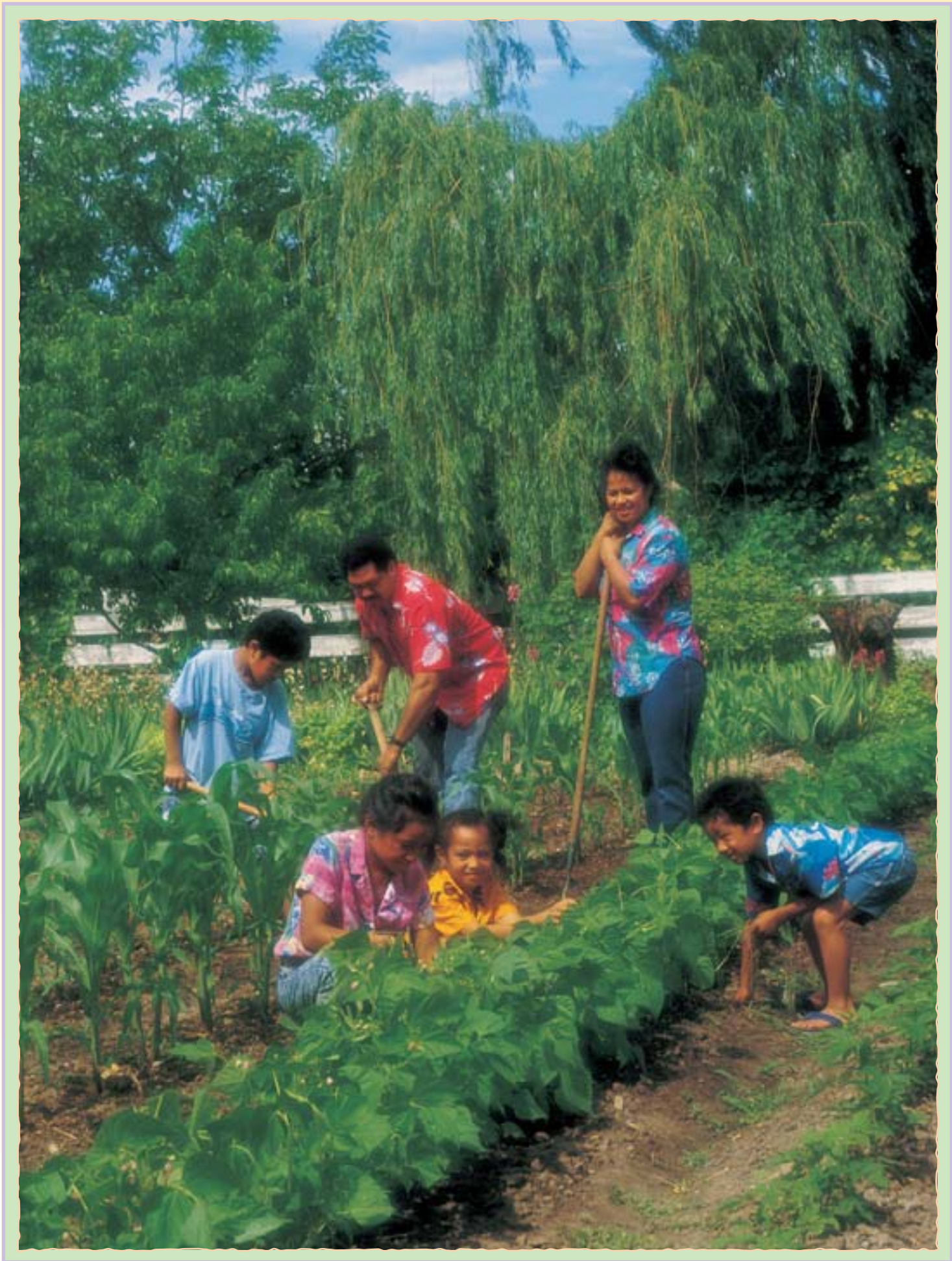

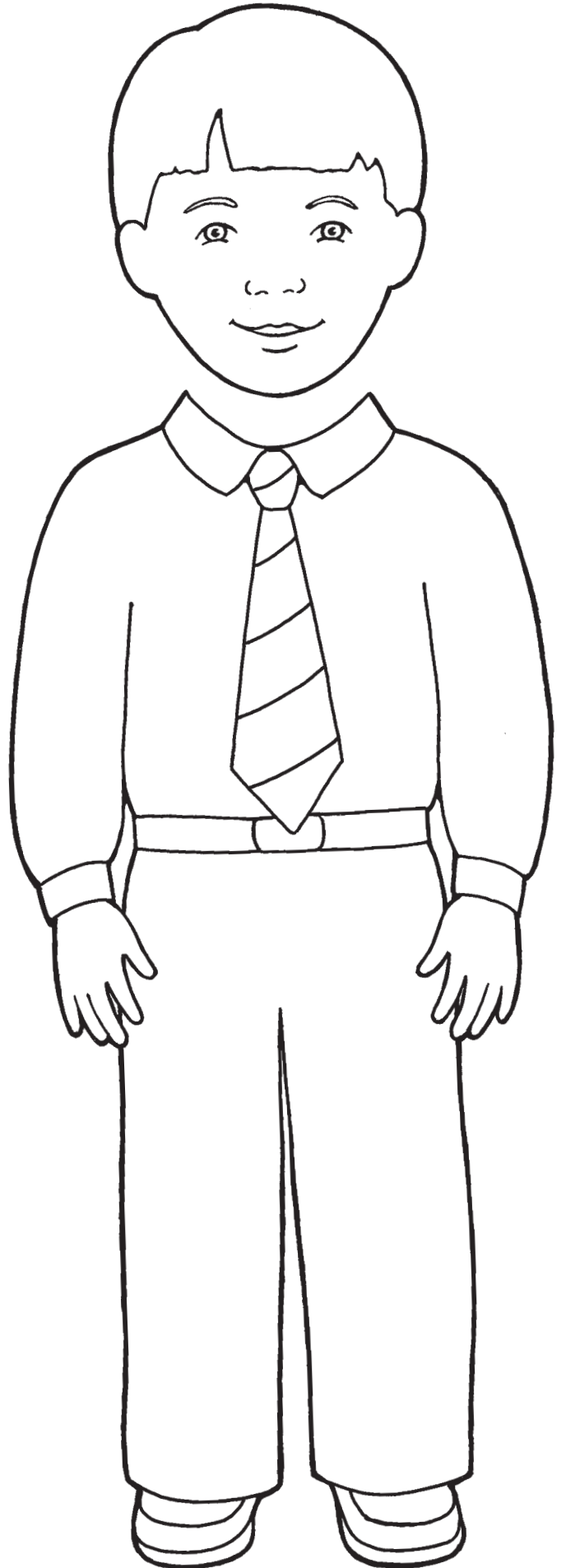
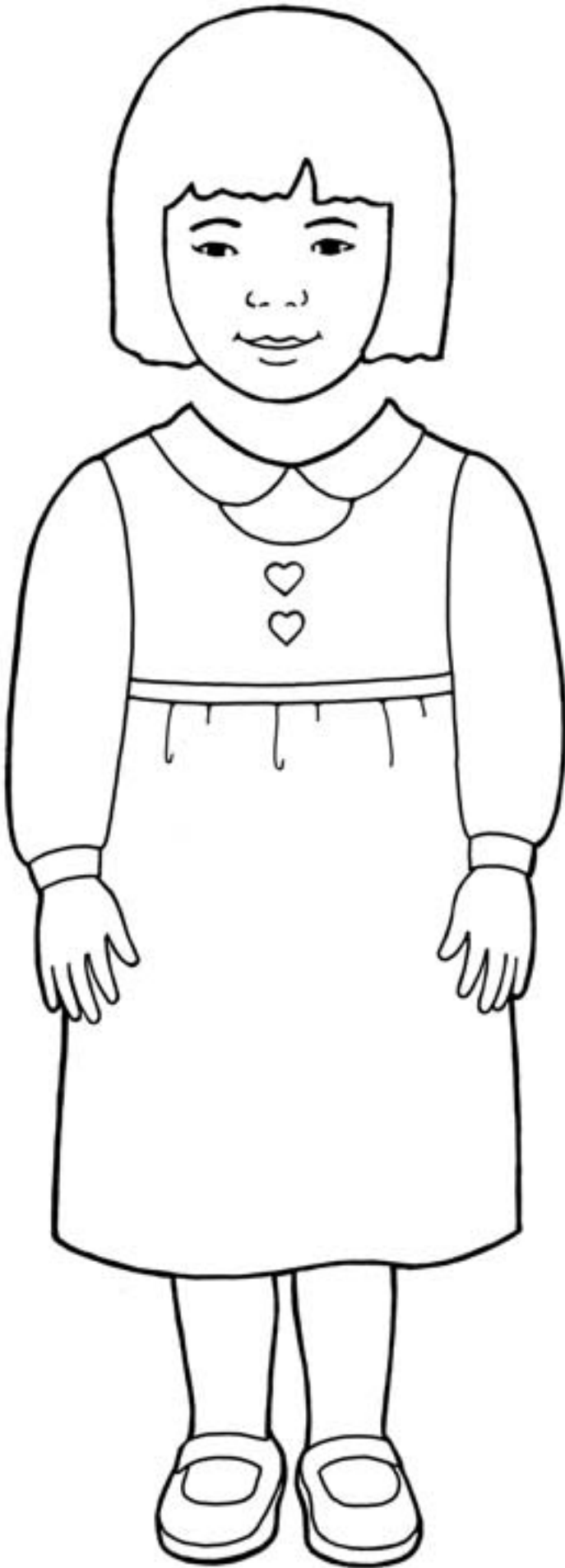

# 15

## I WILL BE THANKFUL

### INTRODUCTION FOR THE TEACHER

To prepare yourself spiritually to teach this lesson, please read and ponder the following:

The Lord has commanded, “Thou shalt thank the Lord thy God in all things” (D&C 59:7). We should express appreciation to God for the many blessings He gives us. We should also be thankful to parents, teachers, friends, and others who help us in any way. (See also Psalm 100:3–4.)

### PREPARATION

- Read Luke 17:11–19, and be prepared to briefly summarize the story of the 10 lepers.
- Bring a copy of the Bible. Mark Luke 17:11–19 so that you can turn to it easily.

### LEARNING ACTIVITIES

Begin with a gathering activity. For ideas, see page 3.

*Prayer* Invite a child to give the opening prayer.

*Doctrinal Instruction* Tell the children that Heavenly Father has given us many blessings, such as our bodies, the plants and animals, our families, and the Church. Explain that we can show our love for Him by saying “thank you” and that we can also say “thank you” to our family and friends and anyone who does something kind for us.

*Scripture Story* Display the picture on page 66. Point out Jesus and the people who were very sick. Open the Bible to Luke 17:11–19 and tell the story of the 10 lepers. Below is an example:

There were 10 men who were very sick. Jesus healed them and made them better (*point to Jesus in the picture*). They were all very happy (*point to the lepers in the picture*). But only one man said “thank you” to Jesus (*point to the thankful leper in the picture*). We can say “thank you” (*invite the children to say “thank you”*).

*Picture* Show the illustration on page 67. Tell the children that we show our love to Heavenly Father by thanking Him for all the things He gives us. Point to one of the illustrations and invite the children to do an action related to that item (such as raising their hands above their heads to make the roof of a house, pretending to pick fruit off a tree and eat it, pretending to put on shoes, and so on). Repeat for each of the illustrations.

*Song* Sing or say the words to verses 1 and 2 of “Thanks to Our Father” (*Children’s Songbook*, 20) and do the actions below. Invite the children to join you.

Thanks to our Father we will bring, (*fold arms*)  
For he gives us everything. (*spread arms out*)



### TEACHING TIPS

*Gathering activities:* Children feel secure when there are regular routines and familiar transitions from one activity to another. This helps them pay attention and be involved.

*Stories:* Be sensitive to the children’s ability to comprehend. Avoid baby talk or words that are too difficult. For example, use “people who were very sick” instead of “lepers.”

Eyes and ears and hands and feet, (*point to eyes, ears, hands, and feet*)  
Clothes to wear, (*point to clothes*)  
and food to eat. (*pretend to eat*)

**Conclusion** Ask the children to say “thank you.” Briefly share your feelings of gratitude for Heavenly Father and Jesus Christ.

**Prayer** Invite a child to give the closing prayer.

## OPTIONAL ACTIVITIES

**PREPARATION** *For the pictures activity:* Bring pictures of things you are thankful for; you could use pictures in this manual or in Church magazines, or you could draw your own.

*For the coloring activity and the matching game:* Copy the illustrations on page 67 for each child to color. Bring small bits of paper or something similar for the children to use as markers for the matching game; bring enough for each child to have at least four markers.

**Activity Verse** Tell the children we are thankful to Heavenly Father for our bodies. Invite the children to stand and do the following activity verse with you. Improvise actions suggested by the words.

Touch your eyes, touch your nose,  
Touch your ears, touch your toes.  
Stretch your hands way up high,  
Even higher, toward the sky.  
Put your hands on your hair.  
Sit down quietly on your chair.

Point to your mouth and say, “I am thankful for my mouth.” Ask the children to repeat the phrase and the action. Repeat for eyes, nose, ears, hands, and feet. Invite the children to suggest things they are thankful for, and repeat the phrase for the things they mention.

**Pictures** Show the children the pictures you have brought and briefly explain why you are thankful for these things. Invite the children to name something they are thankful for.

**Coloring** Let the children color a copy of page 67. While they are coloring, point out details in the pictures and explain to the children what they are coloring. Read the words on the illustration to them.

**Matching Game** Give each child four small bits of paper. Display the illustrations on page 67, point to the illustration of the family, and read the caption to the children. Invite the children to put a bit of paper on the family on their own copy. Invite them to repeat the phrase on the illustration with you. Repeat this activity for the other illustrations.

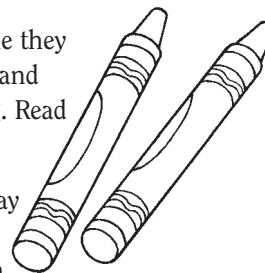

## TEACHING TIPS

**Young children** may not participate throughout the entire lesson. However, with love and encouragement, you can teach them to imitate what you do. Help them say “thank you” at appropriate times. Your example can be your most powerful teaching tool. The children will learn attitudes, conduct, and language by observing you. (See *Teaching, No Greater Call*, 109.)

**Repetition** helps children learn, and it is fun for them. They like to hear things over and over. They can learn short phrases that are repetitive and predictable.



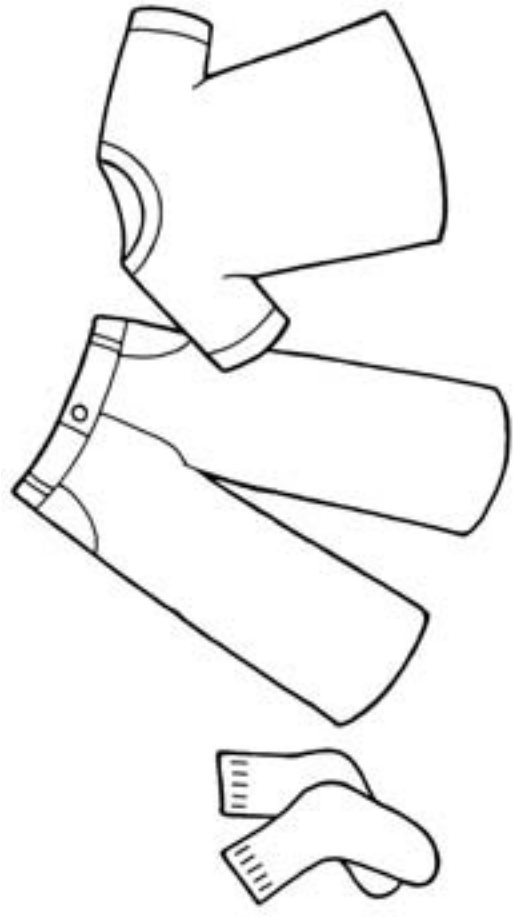

I am thankful for  
my clothes.

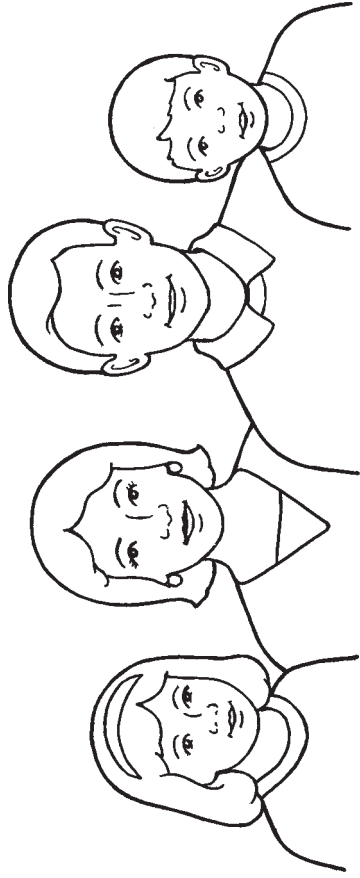

I am thankful for  
my family.

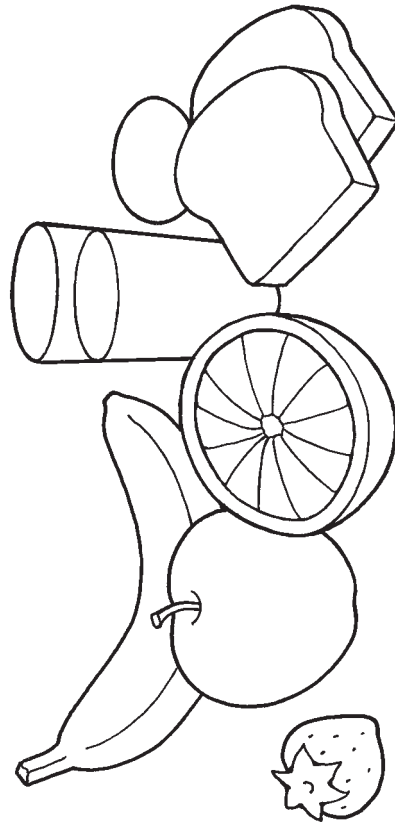

I am thankful for  
food to eat.

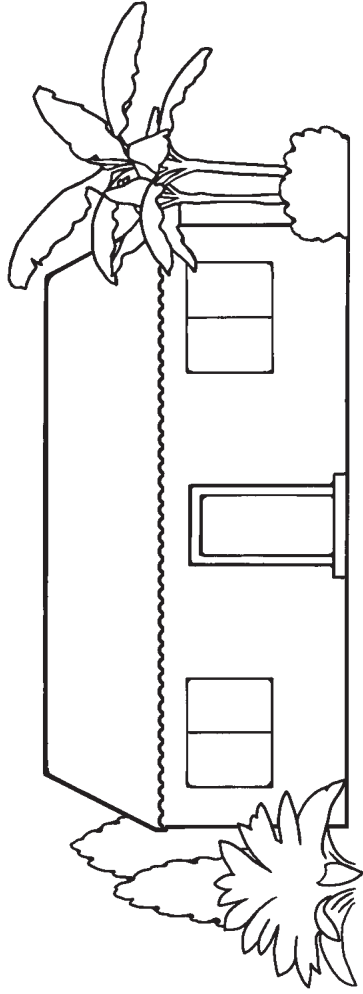

I am thankful for  
my home.



# 16

## I WILL SAY "I'M SORRY"

### INTRODUCTION FOR THE TEACHER

To prepare yourself spiritually to teach this lesson, please read and ponder the following:

Whenever we do something wrong or make a mistake, we should admit our fault and try to correct it (see James 5:16). Our willingness to humble ourselves and apologize can soften hearts and prepare us to come unto Christ (see 3 Nephi 12:23–24).

### PREPARATION

- Mark page 106 in this manual so that you can turn to it easily.
- Read 1 Nephi 17:7–8, 17–19, 49–55; 18:1. Be prepared to briefly summarize the story of Nephi and his brothers building a ship.

### LEARNING ACTIVITIES

Begin with a gathering activity. For ideas, see page 3.

**Prayer** Invite a child to give the opening prayer.

**Picture** Show the picture of Jesus Christ on page 106. Tell the children that Jesus taught us how to be happy. Explain that saying kind words can make us happy and it can make others happy; when we make a mistake or do something that isn't nice, we need to use these kind words: "I'm sorry." Invite the children to say, "I'm sorry."

**Song** Sing or say the words to the chorus of "I'm Trying to Be like Jesus" (*Children's Songbook*, 78–79) and do the actions below. Invite the children to join you.

Love one another as Jesus loves you. (*hug self and turn from side to side*)

Try to show kindness in all that you do. (*nod head up and down*)  
Be gentle and loving in deed and in thought, (*hug self and turn from side to side*)

For these are the things Jesus taught. (*nod head up and down*)

**Scripture Story** Show the picture of Nephi building a ship (page 70) and tell the story of Nephi and his brothers building a ship. Below is an example:

This is Nephi (*point to Nephi in the center of the picture*). The Lord told Nephi to build a ship. A ship is a big boat (*point to the ship in the picture*). These are Nephi's brothers (*point to them in the picture*). Some of them said unkind things to Nephi and would not help him build the ship. Nephi felt sad (*have the children pretend to be sad*). Later Nephi's brothers were sorry and helped him build the ship. Then everyone was happy again (*have the children pretend to be happy*).

Remind the children that when we say, "I'm sorry," we can be happy and help others be happy. Invite the children to say, "I'm sorry."



### TEACHING TIPS

**Songs:** To help children learn a song, sing a short phrase and ask the children to repeat it after you. Then have them repeat an entire line and then the entire song.

**Stories:** Children learn from repetition. Retell stories that the children enjoy at any time during the nursery class. This is a fun way to review with the children what they have learned.

**Dramatization** Have the children pretend to help Nephi build the ship—cut the wood, carry it to the beach, hammer nails in the wood, and lift the sails. Make the motions, sounds, and movements to help engage the children.

**Conclusion** Share your testimony that we can be happy when we say, “I’m sorry.”

**Prayer** Invite a child to give the closing prayer.

## OPTIONAL ACTIVITIES

**PREPARATION** *For the guessing game:* Make a copy of page 71, and cut out one of the circles. Color it if desired. Bring three handkerchiefs or small pieces of cloth.

*For the bracelet activity:* Copy and cut out the circles on page 71 so that each child can have one. Thread some string or yarn through the top of each to make a bracelet or a necklace for each child.

**Guessing Game** Place the three handkerchiefs on the floor. Have the children cover their eyes while you hide the face you’ve cut out under one of the handkerchiefs. Have the children take turns lifting a handkerchief until they find the face. Then read the caption to them and invite them to repeat it with you. Repeat the game until each child who wants a turn has had one.



**Stories** Tell some simple stories to help the children say, “I’m sorry,” such as:

- A girl took her brother’s toy. He was sad (*have the children frown*). Then she said, “I’m sorry” and gave back the toy (*have the children say, “I’m sorry”*). Her brother was happy! (*have the children smile*).
- A boy was running and bumped into his sister. His sister was sad (*have the children frown*). Then he said, “I’m sorry” (*have the children say, “I’m sorry”*). His sister was happy! (*have the children smile*).

Repeat with other examples.

**Bracelets** Give each child a bracelet or necklace to wear. Read the words on the illustration to them.

## TEACHING TIPS

**Dramatization:** Acting out stories from the scriptures helps the children understand and remember what you are trying to teach. (See *Teaching, No Greater Call*, 165–66.)

**Resources:** Use only Church-produced resources in the nursery class. If you need more for the children to do, choose stories, games, puppets, or coloring activities from this manual or from Church magazines. You can use these activities as often as you’d like, and you can teach a lesson two or three weeks in a row.

**Repetition:** If children hear a phrase repeated many times, it can become part of their listening vocabulary. If they say the phrase many times, it can become part of their speaking vocabulary.

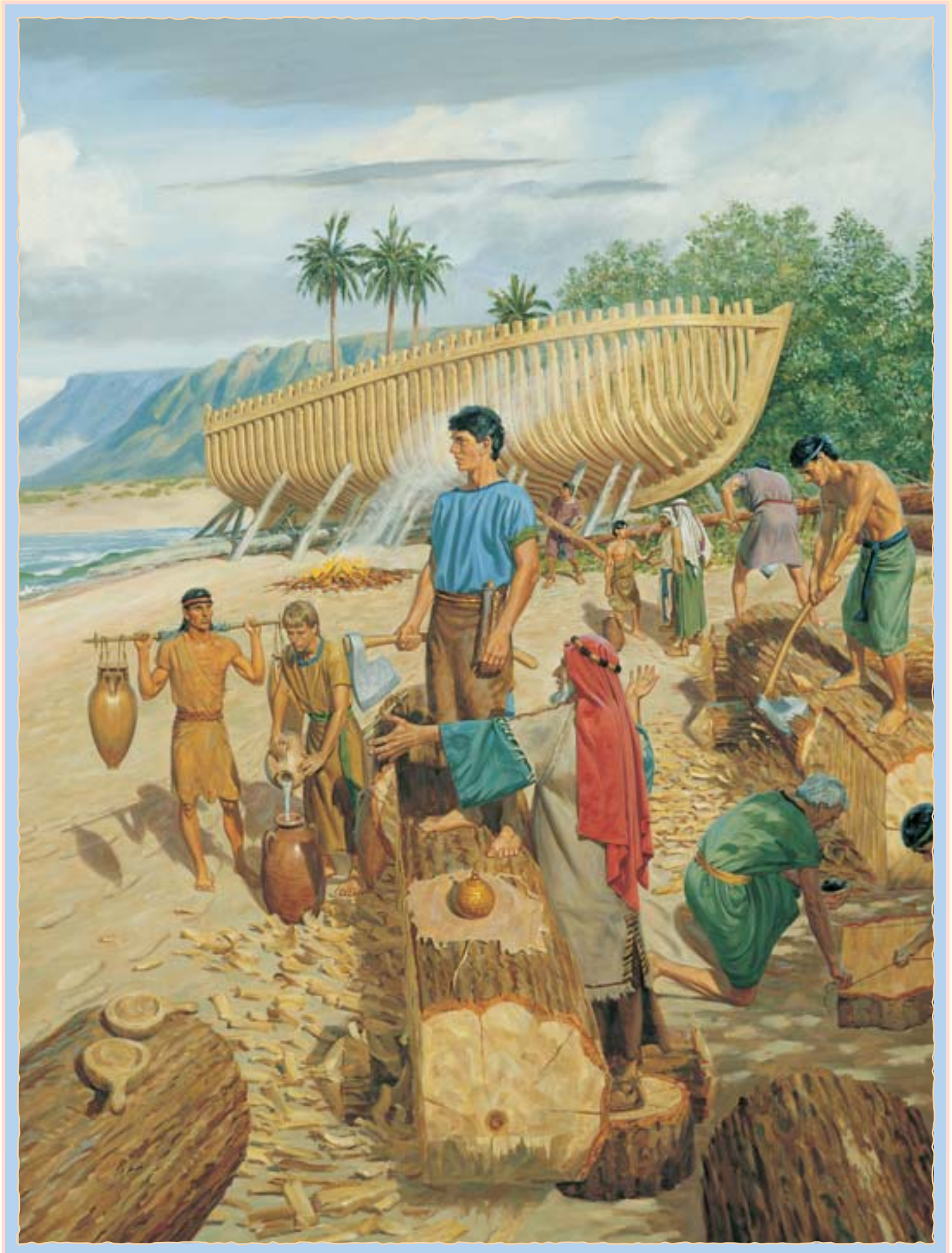



# 17

## I WILL SHARE

### INTRODUCTION FOR THE TEACHER

To prepare yourself spiritually to teach this lesson, please read and ponder the following:

True followers of Jesus Christ have always been known for their willingness to share what they have with others (see, for example, Acts 2:44–45; Mosiah 18:28; 4 Nephi 1:3). By sharing our blessings with those in need, we acknowledge that these blessings come from God, and we show our love for all of His children.

### PREPARATION

Bring a simple object that you can use to demonstrate sharing (you could also use an object in the nursery classroom, such as a toy or a book).

### LEARNING ACTIVITIES

Begin with a gathering activity. For ideas, see page 3.

**Prayer** Invite a child to give the opening prayer.

**Song** Sing or say the words to the chorus of “I’m Trying to Be like Jesus” (*Children’s Songbook*, 78–79) and do the actions below. Invite the children to join you.

Love one another as Jesus loves you. (*hug self and turn from side to side*)

Try to show kindness in all that you do. (*nod head up and down*)

Be gentle and loving in deed and in thought, (*hug self and turn from side to side*)

For these are the things Jesus taught. (*nod head up and down*)

Tell the children that Heavenly Father wants us to be kind to one another. Explain that when we share, we are being kind.

**Demonstration** Tell the children you are going to practice sharing. Show them how to share by saying, “I will share” as you give the other nursery leader the object you have brought. Emphasize the happiness that sharing brings. Invite the children to say, “I will share.”

**Pictures** Show the first picture on page 74. Point to the girl on the left and tell the children that this girl has a doll that she loves to play with; when her friend comes to play, the girl says, “I will share my doll with you.” Point out that they are both happy. Invite the children to say, “I will share.”

Show the second picture on page 74. Point to the boy on the right and tell the children that this boy loves to play with his toys; when his friend comes to play, the boy says, “I will share my toys with you.” Explain that now they are both happy. Invite the children to say, “I will share.”

**Song** Sing or say the following words to “Fun to Do” (*Children’s Songbook*, 253) while you pretend to share with the children. Invite the children to join you.



### TEACHING TIPS

**Sharing** is often hard for young children. They will learn from your example. During the lesson and throughout the nursery class, show them how you share and then let them practice doing it. (See *Teaching, No Greater Call*, 168.) If they are reluctant, simply show them again, without forcing them to share.

Sharing with you is fun to do,  
Fun to do, to do, to do!  
Sharing with you is fun to do,  
To do, to do, to do!

**Conclusion** Tell the children about the happiness you feel when you share. Explain that Heavenly Father also feels happy when we share.

**Prayer** Invite a child to give the closing prayer.

## OPTIONAL ACTIVITIES

**PREPARATION** *For the illustration activity:* Copy the illustration on page 75 for each child.

*For the cube game:* Copy and cut out the illustration on page 75.

Color if desired. Fold along the dotted lines, and tape or glue the tabs to make a cube.

**Illustration** Display the illustration on page 75 and give each child a copy of the illustration. Point to the picture of the smiling boy and explain that we can share our smiles. Invite the children to point to the smiling boy on their copies. Repeat for the other illustrations.

**Cube Game** Roll the cube you made. Have the children do some simple actions to go with the picture on the top of the cube. Then invite the children to say with you, "I will share my [smiles, toys, food, and so on]." When the side with only the words "I Will Share" comes up, have the children clap their hands and say, "I will share." Repeat until each child has had a turn rolling the cube.



**Activity Verse** Recite the following activity verse and invite the children to join you:

I want to follow Jesus,  
Be kind and loving too. (*hug self*)  
I'll share my smiles; (*point to mouth and smile*)  
I'll share my toys. (*pretend to give away a toy*)  
That's what He'd have me do.

## TEACHING TIPS

**Making copies:** If you don't have access to a copy machine, you can place a plain sheet of paper over the illustrations and trace them with a pencil or pen. Don't worry about tracing all of the details; just trace the outlines and enough detail to identify the illustrations.

**Cube game:** If you have many children in your nursery class, you may want to roll the cube yourself each time rather than having the children take turns.

**Activity verses:** Children enjoy poems and songs with simple actions. You can use Church-approved activity verses to help children feel welcome, get ready to pray, learn gospel principles, or participate in a lesson.



I will share crayons.

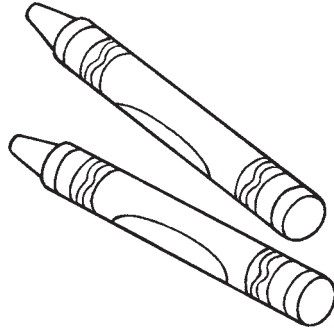

I will share toys.

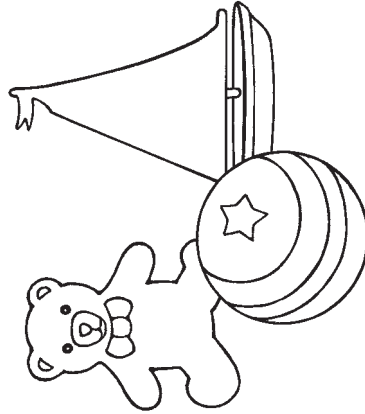

I will share smiles.

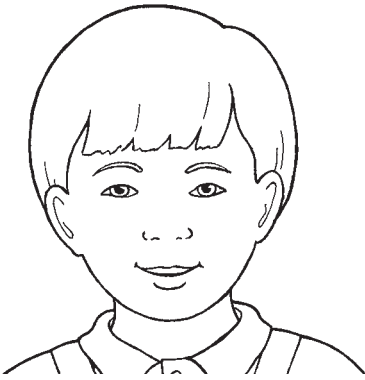

# I Will Share

I will share food.

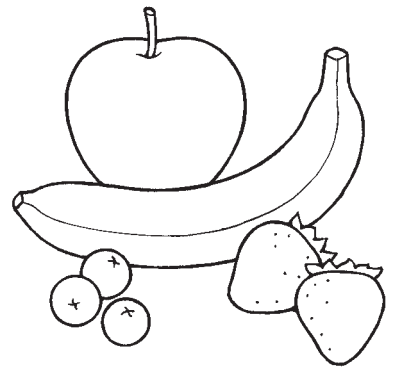

I will share books.

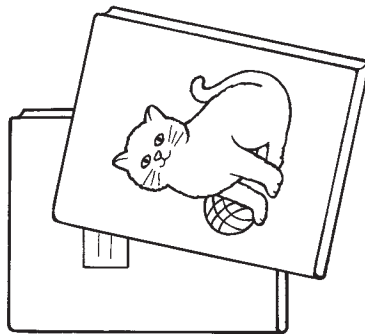



# 18

## I WILL LOVE OTHERS

### INTRODUCTION FOR THE TEACHER

To prepare yourself spiritually to teach this lesson, please read and ponder the following:

Loving others, even those who may be different from us, is one of the most important ways we can follow the Savior Jesus Christ (see John 13:34–35). We show our love for others by being kind to them, listening to them, comforting them, and serving them. (See Matthew 25:34–40; Mosiah 18:8–9.)

### PREPARATION

- Read Luke 10:25–37, and be prepared to tell the story of the good Samaritan very simply.
- Bring a copy of the Bible.
- Mark page 74 in this manual so that you can turn to it easily.

### LEARNING ACTIVITIES

Begin with a gathering activity. For ideas, see page 3.

**Prayer** Invite a child to give the opening prayer.

**Pictures** Show the pictures on page 74. Explain that the children in these pictures are playing kindly together. When we are kind to others, we are showing them love.

**Song** Sing or say the words to “Jesus Said Love Everyone” (*Children’s Songbook*, 61) and do the actions below. Invite the children to join you.

Jesus said love everyone; (*spread arms out wide*)

Treat them kindly too.

When your heart is filled with love, (*put hand over heart*)

Others will love you. (*hug self*)

**Scripture Story** Display the picture of the good Samaritan on page 78. Open the Bible and tell the children that you are going to share a story Jesus told about loving others. Using simple language, tell the story of the good Samaritan. Below is an example:

One day there was a man who was lying on the ground (*point to the injured man in the picture*). He was hurt. Two men walked by. They saw him, but they did not help. A third man came (*point to the good Samaritan in the picture*). He saw the man lying on the ground, and he helped him. He showed love.

**Role Play** Tell the children that Jesus said we should show love too. Invite them to go on a pretend walk, and give them opportunities to pretend to show love for others. For example:

Let’s go for a walk (*walk in place*). Look, there’s a friend who fell down. Let’s help our friend stand up (*pretend to help the friend stand up*). Let’s keep walking. We see a friend who is thirsty. Let’s give our friend a drink of water (*pretend to give a drink*). Let’s keep



### TEACHING TIPS

**Preparation:** “As we teach the gospel, we should humbly recognize that the Holy Ghost is the true teacher. Our privilege is to serve as instruments through whom the Holy Ghost can teach, testify, comfort, and inspire. We should therefore become worthy to receive the Spirit. . . . As you prepare yourself spiritually and acknowledge the Lord in your teaching, you will become an instrument in His hands. The Holy Ghost will magnify your words with power” (*Teaching, No Greater Call*, 41).

**Scriptures:** Use the scriptures as you teach the children. When you tell a story from the scriptures, point to the place in the scriptures where the story is found. Teach the children to appreciate and reverence the scriptures.

walking. We see our mommy and daddy. Let's give them a hug and say, "I love you" (*hug self and say, "I love you"*).

**Conclusion** Sincerely tell the children that you love them. Tell them how happy you feel when you show love for others.

**Prayer** Invite a child to give the closing prayer.

## OPTIONAL ACTIVITIES

**PREPARATION** *For the scripture activity:* Bring a copy of the Bible. Mark John 15:12 so that you can turn to it easily.

*For the coloring activity and the heart activity:* Copy the illustration on page 79 for each child to color.

**Scripture** Tell the children that we learn in the scriptures that Jesus taught us to love one another. Read John 15:12 and do the actions below. Invite the children to join you.

This is my commandment,  
That ye love one another, (*place both hands over heart*)  
as I have loved you. (*spread arms out wide*)

**Coloring** Let the children color a copy of the illustration on page 79. While they are coloring, help them understand that we are all children of God and each one of us is special. Remind them that Heavenly Father and Jesus want us to love everyone.

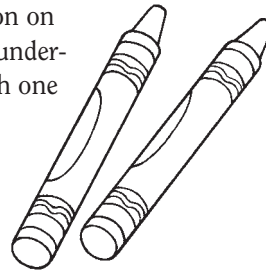

**Heart Activity** Read the following examples (or create some of your own), and ask, "Does this show love?" After each example, have the children hold up their paper hearts and say, "Love."

When you help clean up.

When you say "please" and "thank you."

When you share your toy.

When you help someone who is hurt.

Praise the children for participating. This activity is especially appropriate for older children.

## TEACHING TIPS

**Conclusion:** Smile as you tell the children you love them. Look in their eyes. Your facial expressions and your actions will tell the children even more than your words do.

**Coloring:** Young children may not be able to color within the lines. They may be interested only in making a mark or two on the page. Cheerfully comment on their efforts without asking them to color in a certain way. The purpose of the illustrations in this manual is to give the children a visual representation of the principles in the lesson.

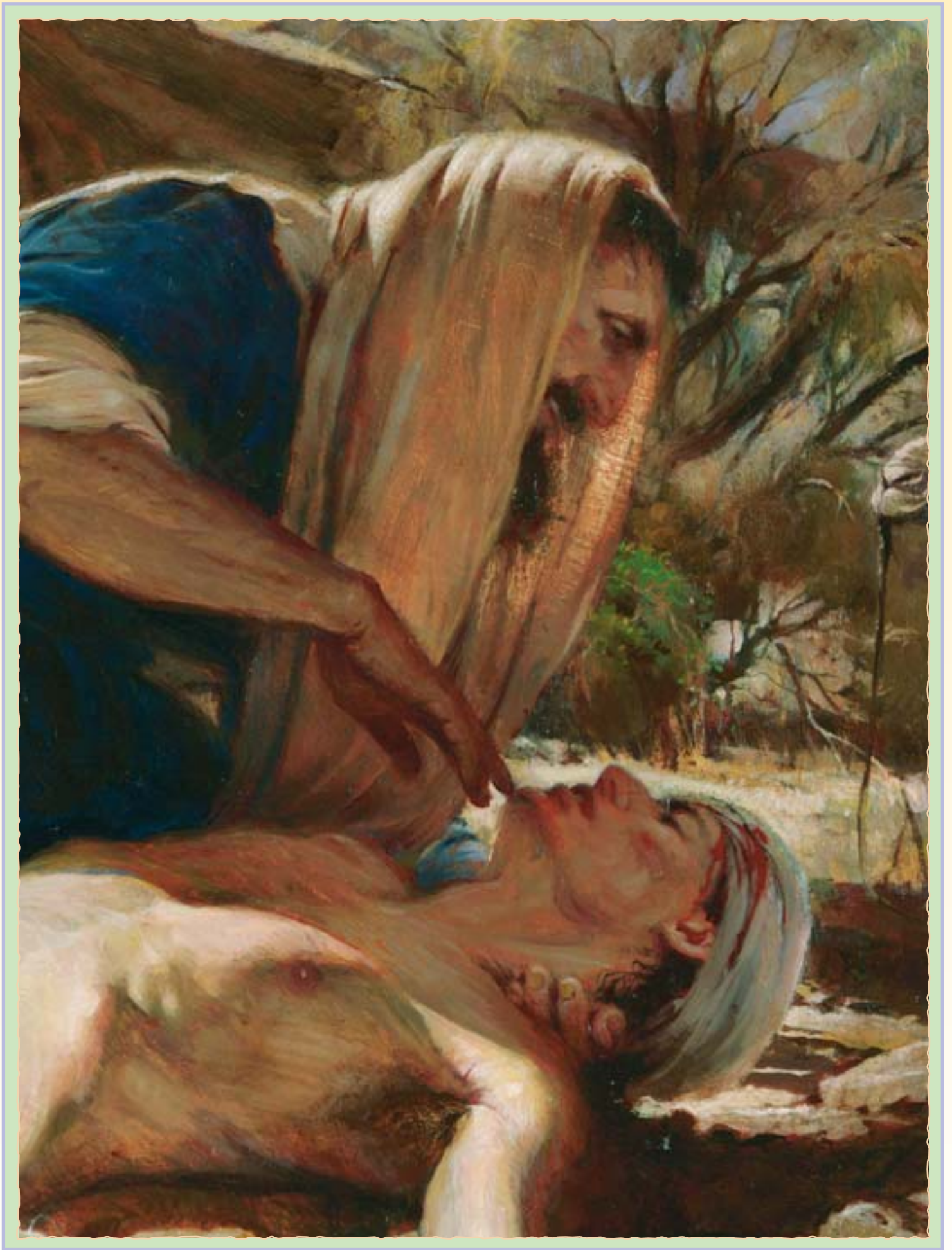

# I Will Love Others

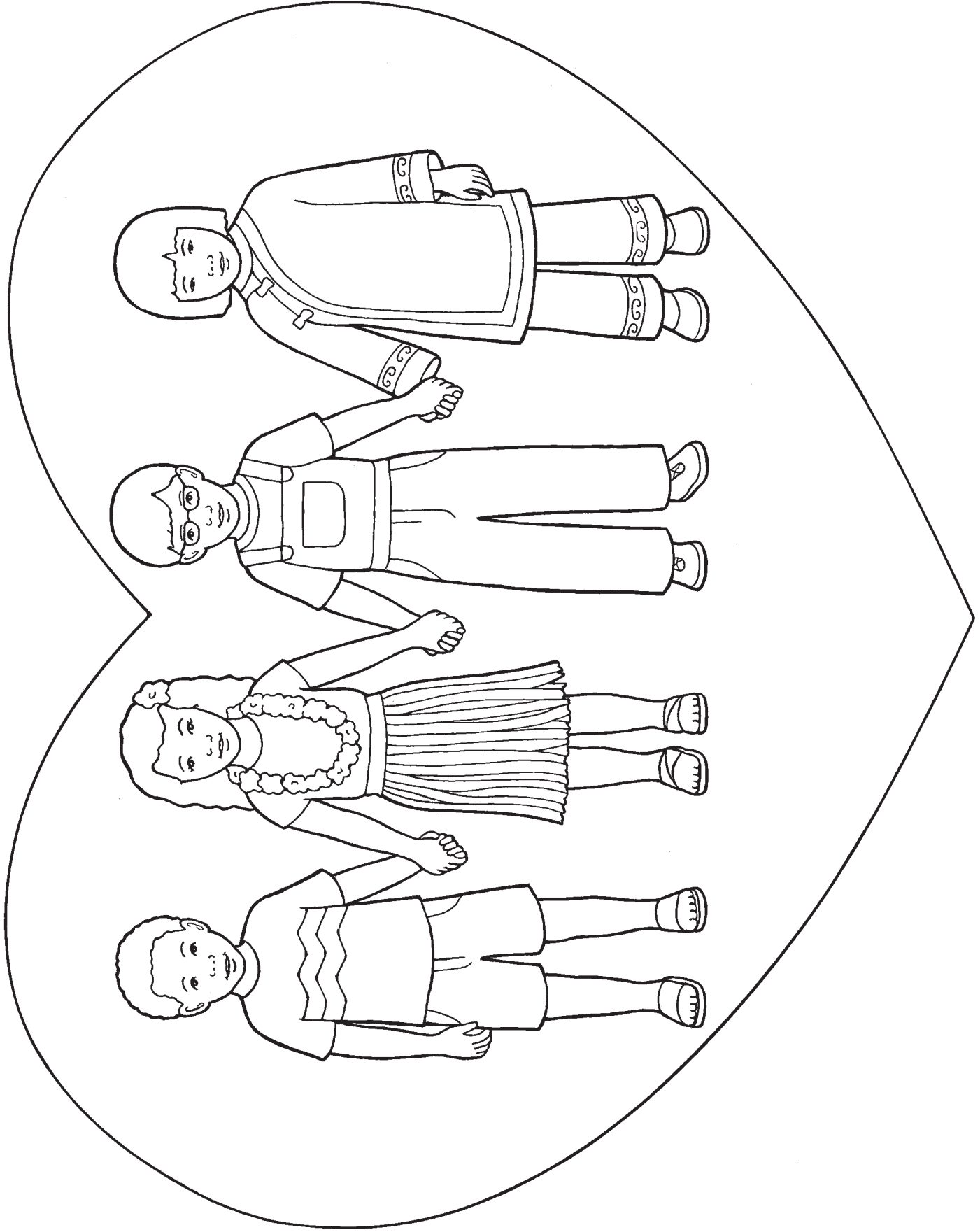

## INTRODUCTION FOR THE TEACHER

To prepare yourself spiritually to teach this lesson, please read and ponder the following:

Our Heavenly Father wants us to be happy; the plan He created for us is often called the “great plan of happiness” (Alma 42:8). Although adversity is an important part of life, we can choose to have a positive outlook, and our cheerful attitude can help others be more optimistic as well.

## LEARNING ACTIVITIES

Begin with a gathering activity. For ideas, see page 3.

**Prayer** Invite a child to give the opening prayer.

**Story** Have a child hold the picture on page 82. Tell the following story:  
Mary and her mommy were going for a walk (*point to Mary and Mommy in the picture*). Some people they passed were frowning (*ask the children to frown*). Mary asked Mommy, “Why are the people so sad?” Mommy said, “I don’t know, but maybe we can smile at them and help them be happy.”

As they walked along, Mary saw a woman coming toward them. Mary smiled her biggest smile (*invite the children to smile their biggest smiles*). When the woman saw Mary’s happy face, she smiled back. Mary said, “It worked!” Mommy said, “When we choose to be happy, it helps others be happy too.”

Ask the children to smile for you. Tell them that their smiles help everyone feel happy. Invite the children to say “happy.”

**Song** Sing or say the words to “Smiles” (*Children’s Songbook*, 267) and do the actions below. Invite the children to join you.

If you chance to meet a frown, (*pull corners of mouth down to a frown*)

Do not let it stay. (*shake head from side to side*)

Quickly turn it upside down

And smile that frown away. (*push corners of mouth into a smile*)

No one likes a frowning face. (*pull corners of mouth down to a frown*)

Change it for a smile. (*push corners of mouth into a smile*)

Make the world a better place

By smiling all the while. (*nod head up and down*)

**Game** Have the children stand in a circle. Tell them you are going to practice sharing smiles. Stand in front of a child and smile at him or her. Invite the child to smile. Then say, “Let’s go share our smiles.” Take the child by the hand, go to another child, and smile. Invite the new child to hold the first child’s hand and share smiles with another child. Continue until all the children are holding hands.



## TEACHING TIPS

**Songs:** Children love things that they have seen and heard before. Sing songs from this lesson or previous lessons at any time during the nursery class. This review will help them learn the songs and remember the gospel principles you have taught.

**Game:** As with any activity, adapt this game to the size of your nursery. If you have many children, you may want to share a smile with two or three children at a time.

*Conclusion* Tell the children that when we choose to be happy, we can help others feel happy too. Invite the children to say, “I can be happy!”

*Prayer* Invite a child to give the closing prayer.

## OPTIONAL ACTIVITIES

*PREPARATION* *For the review activity:* Mark page 67 in this manual so that you can turn to it easily. Bring pictures of things you are thankful for; you could use pictures in this manual or in Church magazines, or you could draw your own.

*For the illustration activity:* Copy the illustration on page 83 for each child.

*Song* Sing or say the words to “If You’re Happy” (*Children’s Songbook*, 266) and do the actions below. Invite the children to join you.

If you’re happy and you know it, clap your hands. (*clap, clap*)

If you’re happy and you know it, clap your hands. (*clap, clap*)

If you’re happy and you know it,

Then your face will surely show it. (*smile; point to face*)

If you’re happy and you know it, clap your hands. (*clap, clap*)

Repeat, replacing “clap your hands” with other actions, such as “turn around,” “pat your knees,” and so on.

*Activity Verse* Recite the following activity verse and invite the children to join you:

A smile is very catchy. (*push corners of mouth into a smile*)

And so when I feel sad, (*push corners of mouth into a frown*)

I try to give a smile away, (*push corners of mouth into a smile*)

And soon I’m feeling glad! (*place both hands over heart*)

*Review* Repeat the two picture activities from lesson 15 (pages 64 and 65). Explain that remembering all the wonderful things Heavenly Father has given us can help us feel happy.

*Illustration* Give each child a copy of the smiling-frowning face on page 83. Invite the children to look at their pictures while you sing the “Smiles” song again. Help them turn their faces from a frown to a smile at appropriate times during the song.

## TEACHING TIPS

*Optional activities:* To maintain the children’s interest and active participation, use a variety of teaching methods; alternate stories with singing, activity verses, games, and movement. Plan no more than two or three minutes for each activity. (See *Teaching, No Greater Call*, 72, 89–90.)

*Review:* Repeat activities from previous lessons as often as you would like. Repetition is fun for the children, and it helps them learn.



I Can Be Happy

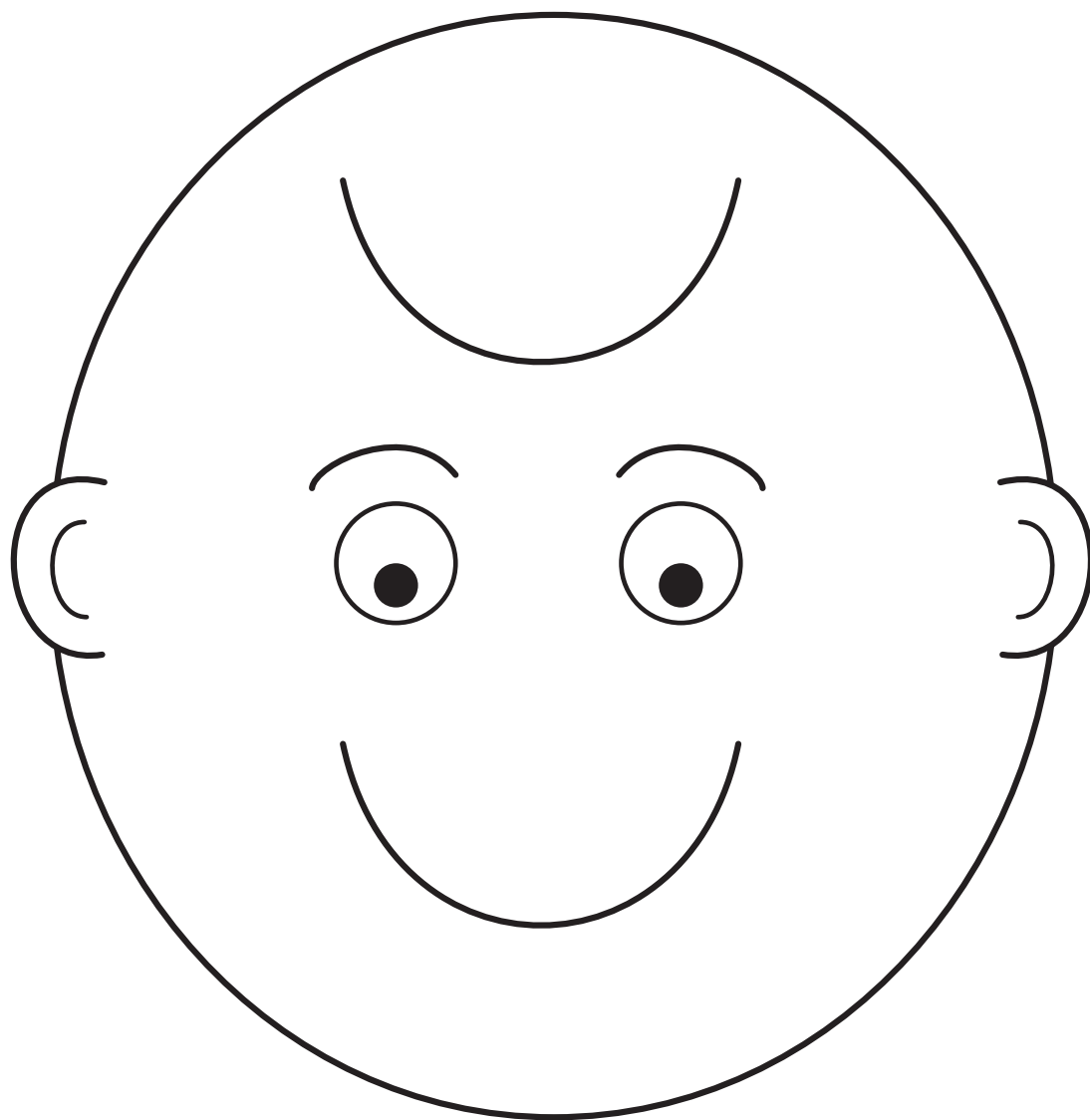



## INTRODUCTION FOR THE TEACHER

To prepare yourself spiritually to teach this lesson, please read and ponder the following:

Reverence is an attitude of deep respect and love for Heavenly Father and Jesus Christ. It is much more than being quiet and sitting still during a lesson, although our reverence is often evident in the way we act at church and in other sacred places. As we strive to become more reverent, we will feel the influence of the Holy Ghost more strongly in our lives. (See D&C 63:64; 84:54; 109:21.)

## LEARNING ACTIVITIES

Begin with a gathering activity. For ideas, see page 3.

**Prayer** Invite a child to give the opening prayer.

**Picture** Show the picture on page 86. Tell the children that this family is at church and that they are being reverent. Invite the children to say “reverent.” Explain that being reverent means quietly thinking about Heavenly Father and Jesus Christ. Point out things that the family in the picture is doing to show that they are reverent. Draw particular attention to the children in the picture.

**Practice** Help the children understand that when we come to church we can show our love for Heavenly Father and Jesus by being reverent. Describe some of the ways we show reverence at church, and practice doing them with the children. For example:

- We talk with quiet voices. (*practice talking quietly*)
- We walk with quiet feet. (*practice walking quietly*)
- We sit quietly. (*practice sitting quietly*)
- We listen to our teachers. (*cup hand around ear*)
- We think about Jesus. (*point to head*)

**Song** Explain that another way we show reverence is by singing reverent songs. Sing or say the words to “I Will Try to Be Reverent” (*Children’s Songbook*, 28) and do the actions below. Invite the children to join you.

I love my Heavenly Father, (*put hands over heart*)

And I will try to be (*point to self*)

Reverent when I’m in his house. (*put fingertips together to form a housetop*)

Then he’ll be near to me. (*hug self*)

**Conclusion** Compliment the children for being reverent. Explain that these things help us and those around us think about Heavenly Father and Jesus. Ask the children to say, “I will be reverent.” Invite them to be reverent today.

**Prayer** Tell the children that it’s time for the closing prayer. Ask, “How can you be reverent during the prayer?” Help them practice folding their arms, bowing their heads, and closing their eyes while you give the prayer.



## TEACHING TIPS

**Reverence:** “Anticipate simple things you can do to remind [the children] to be reverent. You may be able to restore a reverent atmosphere by quietly singing or humming a reverent song, displaying a picture, or using a hand signal that the children recognize as a reminder to be reverent.”

“Remember that it is especially difficult for children to sit still for long periods of time. Help children listen and participate actively. Give them breaks periodically” (*Teaching, No Greater Call*, 83).

**Repeating phrases:** Some children may not repeat phrases with you. That’s OK. They will still learn by watching and listening to you and the other children.

Remind the children that doing this helps us show Heavenly Father and Jesus that we love Them. Praise them for showing reverence.

## OPTIONAL ACTIVITIES

**PREPARATION** *For the flip-book activity:* Copy the illustration on page 87; color if desired. Cut along the solid line to make two flaps. Fold the flaps over to cover the drawing.

*For the coloring activity:* Copy the illustration on page 87 for each child to color. Cut along the solid line to make flip books for the children.

**Flip Book** Hold up the illustration you prepared, with the flaps covering the drawing. Tell the children that you will show them some pictures that show us how to be reverent during a prayer. Open the top flap and read the words on the inside of the flap. Do the same with the bottom flap. Repeat the activity; this time invite the children to practice bowing their heads, closing their eyes, and folding their arms.

**Activity Verse** Recite the following verse and invite the children to join you:

Open, shut them; (*open and shut hands*)

Open, shut them; (*open and shut hands*)

Give a little clap. (*clap hands*)

Open, shut them; (*open and shut hands*)

Open, shut them; (*open and shut hands*)

Lay them in your lap. (*hold hands together in lap*)

**Coloring** Let the children color a copy of the flip books you prepared for them.

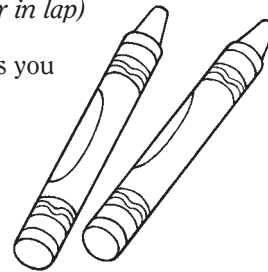
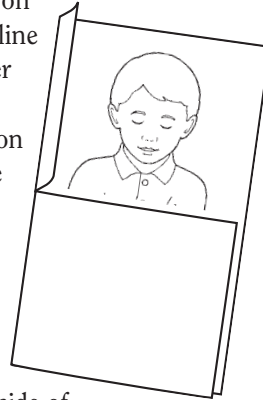

## TEACHING TIPS

**Praise:** “Do not reward reverent behavior with prizes or food. Do not have contests to see who can be the most reverent. These tend to focus on the wrong things. Teach about the real rewards of reverence, such as increased understanding and the influence of the Spirit” (*Teaching, No Greater Call*, 83). Give the children specific verbal praise when they show reverence; for example: “I like the way Mary is sitting so reverently. Thank you, Mary.”

**Coloring:** While the children are coloring, review the principles taught in the lesson. Point out details in the pictures, and explain to them what they are coloring. Read the words on the illustration to them.



I close my eyes  
and bow my head

and fold my arms  
while the prayer is said.

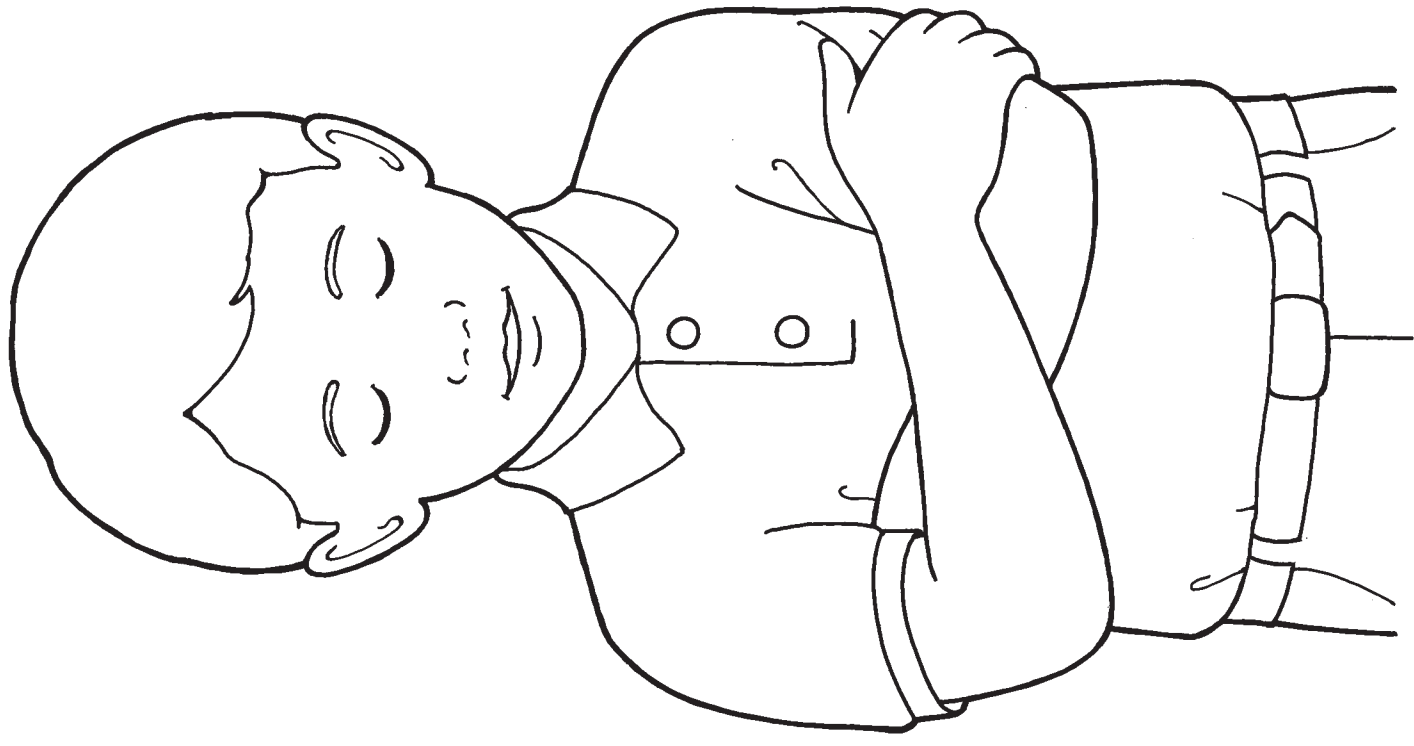

# 21

## JOSEPH SMITH SAW HEAVENLY FATHER AND JESUS CHRIST

### INTRODUCTION FOR THE TEACHER

To prepare yourself spiritually to teach this lesson, please read and ponder the following:

Joseph Smith was the first prophet of our day. He saw and spoke with God the Father and Jesus Christ. Through the Prophet Joseph, the Lord restored the true Church and the fulness of the gospel. (See Joseph Smith—History 1:9–19.)

### PREPARATION

- Read Joseph Smith—History 1:9–19 and be prepared to briefly tell the story of the First Vision.
- Bring a copy of the Bible.
- Bring a copy of the Pearl of Great Price. Mark Joseph Smith—History 1:17 so that you can turn to it easily.

### LEARNING ACTIVITIES

Begin with a gathering activity. For ideas, see page 3.

*Prayer* Invite a child to give the opening prayer.

*Scripture Story* Show the picture on page 90 as you briefly tell the story of the First Vision (see Joseph Smith—History 1:9–19). Below is an example:  
This is a picture of Joseph Smith (*point to Joseph; invite the children to say “Joseph Smith”*). He wanted to know which church was true. He read in the Bible (*open the Bible*) that we can pray to know the truth (*invite the children to pretend to read*). Joseph went to a grove of trees (*point to the trees*) to ask Heavenly Father in prayer. While he was praying, he saw Heavenly Father and Jesus Christ.

Open the Pearl of Great Price to Joseph Smith—History 1:17 and tell the children that you are going to read what Heavenly Father said to Joseph Smith. Explain that He pointed to Jesus Christ and said: “This is My Beloved Son. Hear Him!” Explain that Jesus told Joseph that He would bring back the true Church of Jesus Christ.

*Exercise* Tell the story again. This time, have the children stand with outstretched arms to pretend to be trees in the Sacred Grove. Ask the children to sway as if being blown by the wind while you talk about Joseph praying. Then ask them to stand very still and quiet when you tell them Heavenly Father and Jesus appeared to Joseph.

*Song* Sing or say the following words to “On a Golden Springtime” (*Children’s Songbook*, 88) and do the actions below. Invite the children to join you.  
On a golden springtime, in a forest glade, (*hold arms up like trees*)  
The Father and the Son appeared as Joseph knelt and prayed. (*kneel and fold arms*)



### TEACHING TIPS

*Stories:* Young children have short attention spans. Plan ways to involve them in the story. For example, you could have them hold pictures or repeat phrases. Stop frequently to point out details in the pictures, and display them long enough for each child to see them before you proceed with the story. (See *Teaching, No Greater Call*, 181.)

*Songs:* “The appealing rhythms of music help children remember what they sing and the messages of the words” (*Teaching, No Greater Call*, 174). Music is also an effective way to invite the Spirit in the class.

**Conclusion** Briefly share your testimony that Joseph Smith saw Heavenly Father and Jesus Christ.

**Prayer** Invite a child to give the closing prayer.

### OPTIONAL ACTIVITIES

**PREPARATION** *For the finger-puppet activity:* Copy and cut out the finger puppets on page 91 or use the puppets you made for the optional activity in lesson 9. Color the puppets if desired.

*For the coloring activity:* Copy the illustration on page 91 for each child to color.

**Activity Verse** Recite the following activity verse, and invite the children to join you:  
Joseph knelt among the trees, (*hold arms up like trees*)

And said a special prayer. (*fold arms*)

He saw the Father and the Son (*look up, shading eyes with hand*)

And listened to Them there. (*cup hand around ear*)

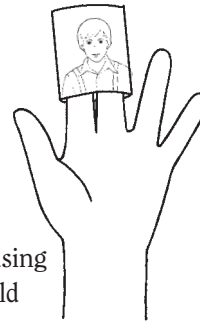

**Finger-Puppet Activity** Briefly retell the story of the First Vision, this time using the finger puppets you prepared. Let the children hold the puppets if they'd like.

**Coloring** Let each child color a copy of the illustration on page 91. While they are coloring, review the story of the First Vision. Point out details in the picture and explain to the children what they are coloring. Read the words on the illustration to them.

### TEACHING TIPS

**Testimony:** Express your testimony in a simple, concise way; for example: "I know that Joseph Smith saw Heavenly Father and Jesus Christ."

**Finger puppets:** If you choose to do this activity, you may want to make enough finger puppets so that each child can play with one.

**Older children:** Consider inviting the older children to retell the story of the First Vision to the younger children. Show them how to use the finger puppets or the picture on page 42 to tell the story. Helping the children teach each other is a great way to reinforce what you have taught them.

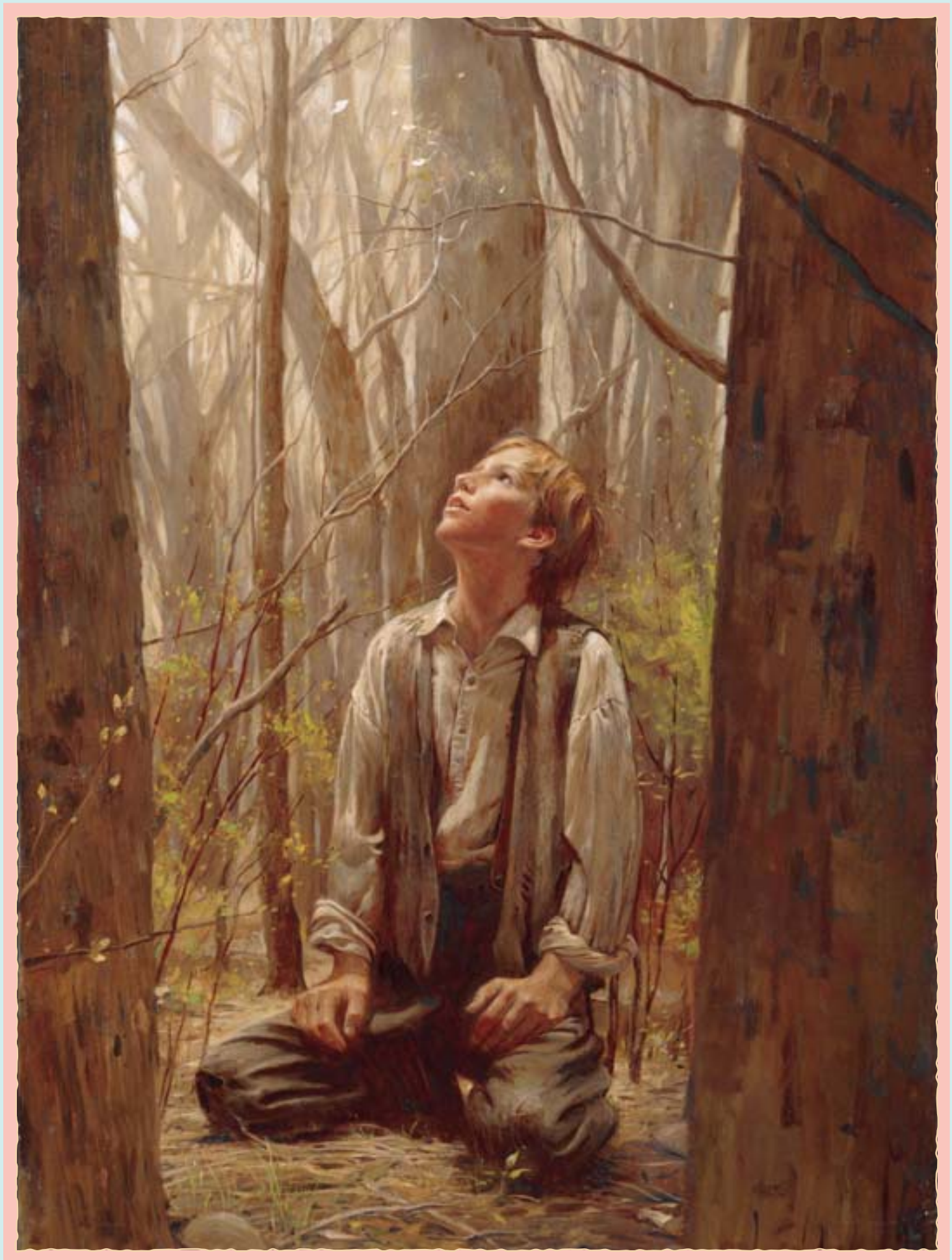

# Joseph Smith Saw Heavenly Father and Jesus Christ

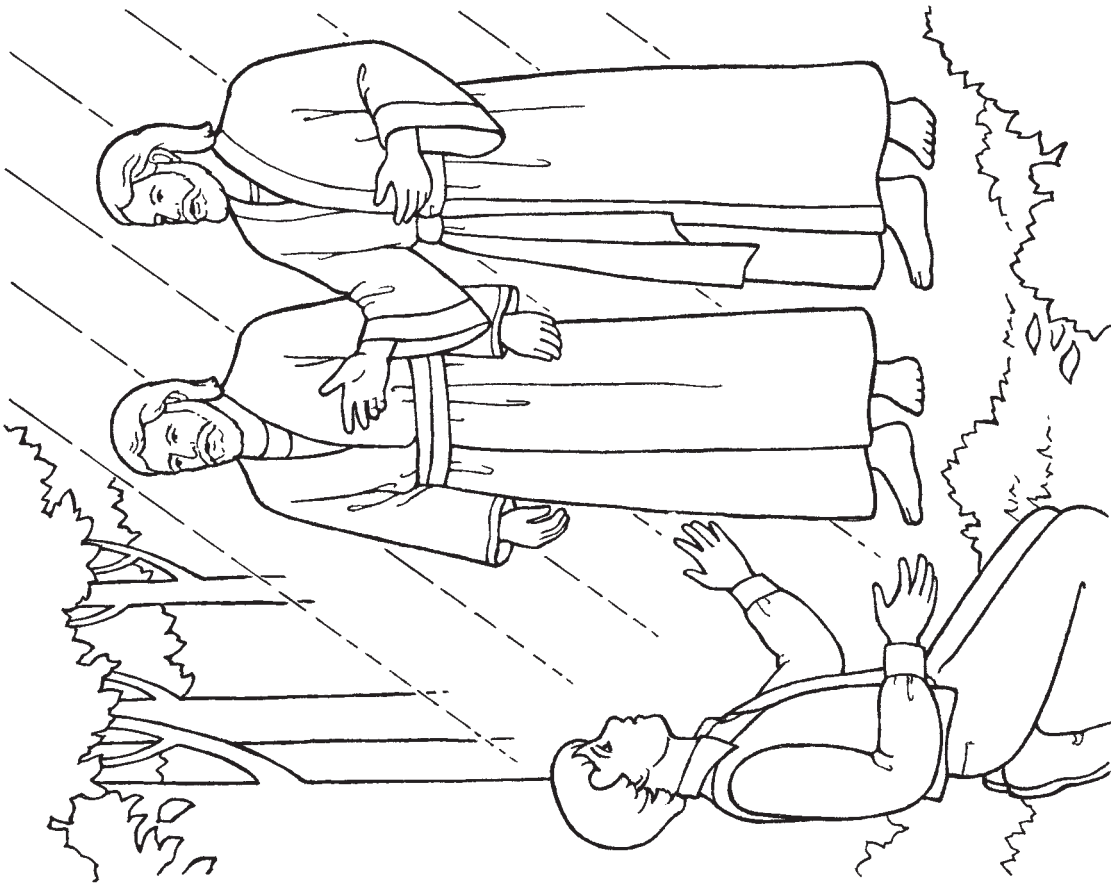

Copy this page and cut out the finger puppets on the solid, straight lines. Fold on the dotted lines. Then tape the sides, leaving the bottom edges open so the children can put the puppets on their fingers.

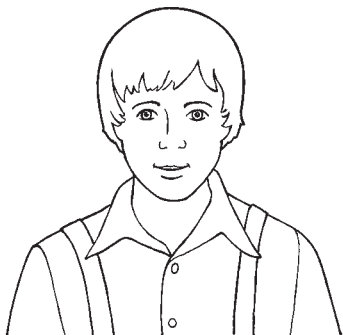



## INTRODUCTION FOR THE TEACHER

To prepare yourself spiritually to teach this lesson, please read and ponder the following:

The Book of Mormon is a powerful witness of Jesus Christ. It contains the testimony of ancient prophets who foresaw His coming and understood His mission. It also contains a record of His visit to the Americas shortly after His Resurrection (see 3 Nephi 11–27). The main purpose of the Book of Mormon is to convince all people “that Jesus is the Christ, the Eternal God, manifesting himself unto all nations” (title page of the Book of Mormon; see also 1 Nephi 13:40–41; 2 Nephi 25:26; 33:10–11).

## PREPARATION

- Mark pages 22, 94, and 126 in this manual so that you can turn to them easily.
- Bring a copy of the Book of Mormon.

## LEARNING ACTIVITIES

Begin with a gathering activity. For ideas, see page 3.

*Prayer* Invite a child to give the opening prayer.

*Song* Sing the chorus of “Search, Ponder, and Pray” (*Children’s Songbook*, 109) and do the actions below. Invite the children to join you.

Search, (*pretend to open a book*)

ponder, (*point to head*)

and pray (*fold arms*)

Are the things that I must do. (*point to self*)

The Spirit will guide, and, deep inside, (*put hand on chest*)

I’ll know the scriptures are true. (*point to head*)

*Pictures* Hold up the Book of Mormon. Tell the children, “This is the Book of Mormon. The Book of Mormon teaches us about Jesus.” Invite the children to say “Book of Mormon.” Open the Book of Mormon and place it in front of you.

Display the picture of the Nativity (page 126 of this manual). Point to the Book of Mormon and tell the children that the Book of Mormon teaches that Jesus Christ came to earth.

Display the picture of Jesus healing the Nephites (page 94). Point to the Book of Mormon and tell the children that the Book of Mormon teaches that Jesus healed people who were sick.

Display the picture of Jesus blessing the Nephite children (page 22). Point to the Book of Mormon and tell the children that the Book of Mormon teaches that Jesus blessed the children.

*Conclusion* Have the children say, “The Book of Mormon teaches me about Jesus Christ,” a few words at a time. Tell them that you know the Book of Mormon is true.

*Prayer* Invite a child to give the closing prayer.

TEACHING  
TIPS

*Preparation:* If you are well prepared with stories, pictures, and games before the nursery class begins, you will be able to focus your attention on the children. Prayerfully seek the guidance of the Spirit as you prepare to teach.

*Songs:* You can use Primary songs in almost any lesson to introduce or summarize an idea. Primary songs help children learn and remember gospel principles. They also allow children to bear their testimonies simply and beautifully.

*Scriptures:* Opening the scriptures and pointing to them while you are teaching helps the children understand that the stories of Jesus come from the scriptures.

## OPTIONAL ACTIVITIES

**PREPARATION** *For the bag game:* Copy the illustrations on page 95.

Cut along the dotted lines. Put the pictures in a bag or other container.

*For the book:* Make a copy of page 95 for each child to color.

**Activity Verse** Recite the following activity verse and invite the children to join you:

Read the Book of Mormon. (*start with hands together, then open like a book*)

Read it every day.

Before you start to study, (*point to head*)

Don't forget to pray. (*fold arms*)

[Terri Clark, "Read the Book of Mormon," *Friend*, Mar. 2004, 11]

**Bag Game** Ask a child to choose an illustration from the bag or container. Read the caption on the illustration to the children. Repeat until each child who wants a turn has had one.

**Book** Let each child color a copy of the illustrations on page 95. While they are coloring, talk to them about the illustrations. Point to Jesus in each picture. When they are finished, fold along the dotted lines to make a book. Then read the book to the children.

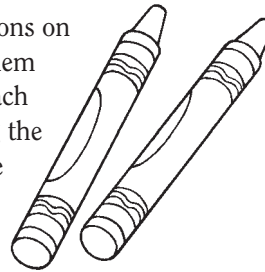
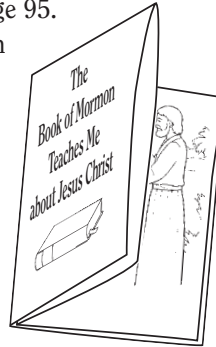

## TEACHING TIPS

**Activities:** Keep the children engaged by using a variety of activities. This is probably the best way to prevent disruptive conduct. (See *Teaching, No Greater Call*, 72, 80.)

**Young children** are easily distracted. While one nursery leader is teaching or leading an activity, the other nursery leader can help direct the children's attention to the activity. Giving a child something to hold can also help him or her stay actively involved in the activity.



The Book of Mormon teaches that Jesus came to earth  
(see Alma 7:10-12).

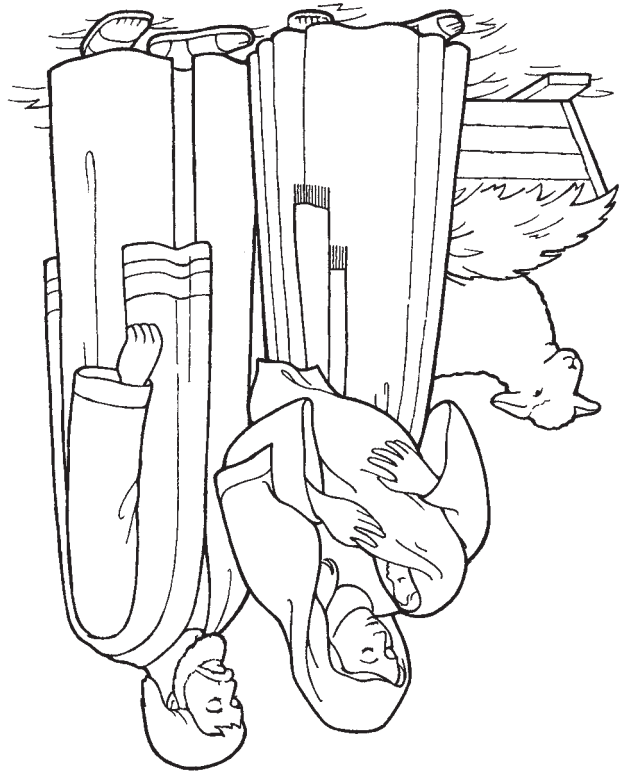

The Book of Mormon teaches that Jesus healed the sick  
(see 3 Nephi 17:7-10).

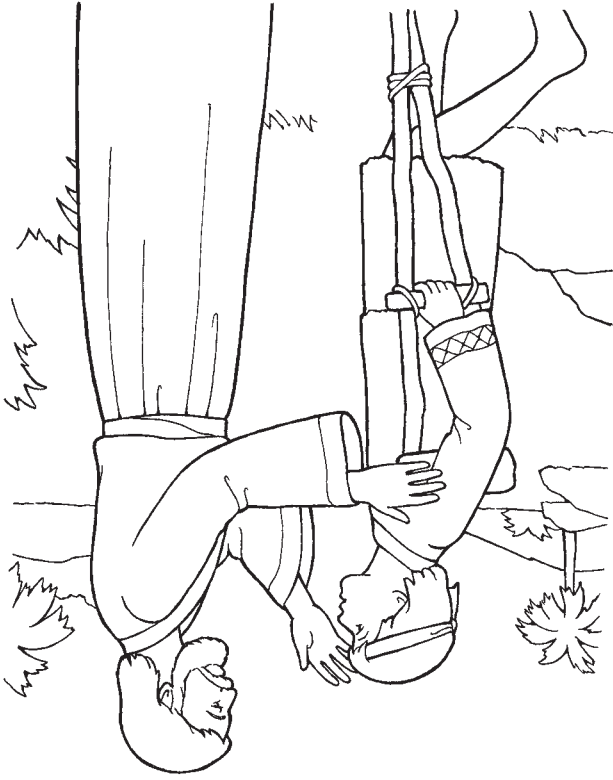

# The Book of Mormon Teaches Me about Jesus Christ

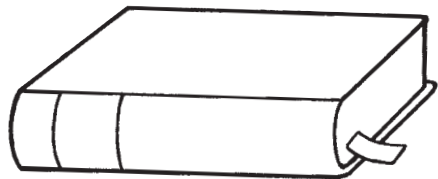

The Book of Mormon teaches that Jesus blessed the  
children (see 3 Nephi 17:21-24).



## INTRODUCTION FOR THE TEACHER

To prepare yourself spiritually to teach this lesson, please read and ponder the following:

The Church of Jesus Christ of Latter-day Saints accepts the Bible, the Book of Mormon, the Doctrine and Covenants, and the Pearl of Great Price as scripture. The purpose of the scriptures is to testify of Jesus Christ, helping us come unto Him and receive eternal life (see 2 Nephi 25:26; Helaman 3:29–30). The scriptures also contain stories about people who were blessed for obeying Heavenly Father. Nephi expressed his love for the scriptures in this way: “My soul delighteth in the scriptures, and my heart pondereth them” (2 Nephi 4:15).

## PREPARATION

- Read Mark 10:13–16 and 1 Nephi 17:7–10; 18:1–4. Be prepared to summarize these stories briefly for the children.
- Bring your copy of the scriptures.
- Mark page 70 in this manual so that you can turn to it easily.

## LEARNING ACTIVITIES

Begin with a gathering activity. For ideas, see page 3.

*Prayer* Invite a child to give the opening prayer.

*Doctrinal Instruction* Show the children your scriptures and tell them how much you love the scriptures. Invite the children to say “scriptures.” Tell them that we learn about Heavenly Father and Jesus Christ from the scriptures; we learn that They love us and want us to be happy.

*Scripture Stories* Display the picture on page 98 and point to Jesus. Explain that the scriptures teach us about Jesus. Open the Bible and briefly summarize the story of Jesus blessing the children (see Mark 10:13–16). The following is an example:

Jesus loves children. One day some people brought their little children to Jesus (*point to the children in the picture*). He took them in His arms and blessed them.

Display the picture on page 70. Explain that the scriptures tell us about people who were blessed when they obeyed Heavenly Father. Open the Book of Mormon and briefly summarize the story of Nephi building a ship (see 1 Nephi 17:7–10; 18:1–4). The following is an example:

This is Nephi (*point to Nephi in the picture*). The Lord told Nephi to build a ship. Nephi had never built a ship before, but he obeyed. The Lord showed him how to build the ship. (*Have the children pretend to build a ship.*)

*Song* Sing or say the chorus to “Search, Ponder, and Pray” (*Children’s Songbook*, 109) and do the actions below. Invite the children to join you.

Search, (*pretend to open the scriptures*)  
ponder, and pray (*fold arms*)  
Are the things that I must do. (*point to self*)



## TEACHING TIPS

*Scriptures:* “When you teach children, you should use the scriptures frequently and find ways to have the children become comfortable using the scriptures” (*Teaching, No Greater Call*, 59). Help them become familiar with the people and the stories in the scriptures. Help them see that what you teach them comes from the scriptures.

*Songs:* When singing or reciting a verse to children, memorize the words and actions. This will enable you to maintain eye contact and show them your enthusiasm for the activity.

The Spirit will guide, and, deep inside,  
I'll know the scriptures are true. (*pretend to hold an open book*)

**Conclusion** Have the children repeat the phrase, "I love the scriptures." Share your love for the scriptures and your testimony that they are true.

**Prayer** Invite a child to give the closing prayer.

## OPTIONAL ACTIVITIES

**PREPARATION** *For the puppet activity:* Copy and cut out the figures on page 99 for each child and make an additional copy for yourself. Tape or glue a stick to the back of each figure to make stick puppets.

**Puppet Activity** Let the children color the figures you have cut out. When they are finished, hold up your Adam and Eve puppet and invite the children to hold up theirs. Ask them to say "Adam and Eve." Open the Old Testament and tell the children that the scriptures tell us Adam and Eve were the first people on earth; they lived in the Garden of Eden. Have the children pretend to make their puppets walk in the garden.



Hold up your Noah puppet and invite the children to hold up theirs. Ask them to say "Noah." Tell them that the scriptures tell us Noah built an ark and gathered animals into his ark. Have the children pretend to be animals.

Hold up your Moses puppet and invite the children to hold up theirs. Ask them to say "Moses." Tell them that the scriptures tell us the Lord gave Moses 10 commandments. Invite the children to hold up 10 fingers while you count to 10.

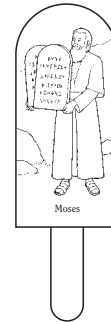

**Activity Verse** Recite the following activity verse and invite the children to join you:

Teach me the scriptures; (*pretend to read scriptures*)  
They tell me the truth. (*point to self*)  
Teach me how prophets obey.  
Teach me the scriptures; (*pretend to read scriptures*)  
I must know the truth. (*point to self*)  
Teach me so I'll know the way.

## TEACHING TIPS

**Coloring:** While the children are coloring, tell them about the people in the illustrations. Explain that the scriptures tell us true stories about these people and many others who obeyed Heavenly Father.

If you prefer, you could wait to assemble the children's stick puppets until after they have colored the illustrations. Or you could let the children take the illustrations home for their parents to assemble.

**Activity verses:** You can use activity verses at any time during the nursery class, whenever the children need to move around, or when you need to engage their attention. They are also a good way to review principles you have taught previously.



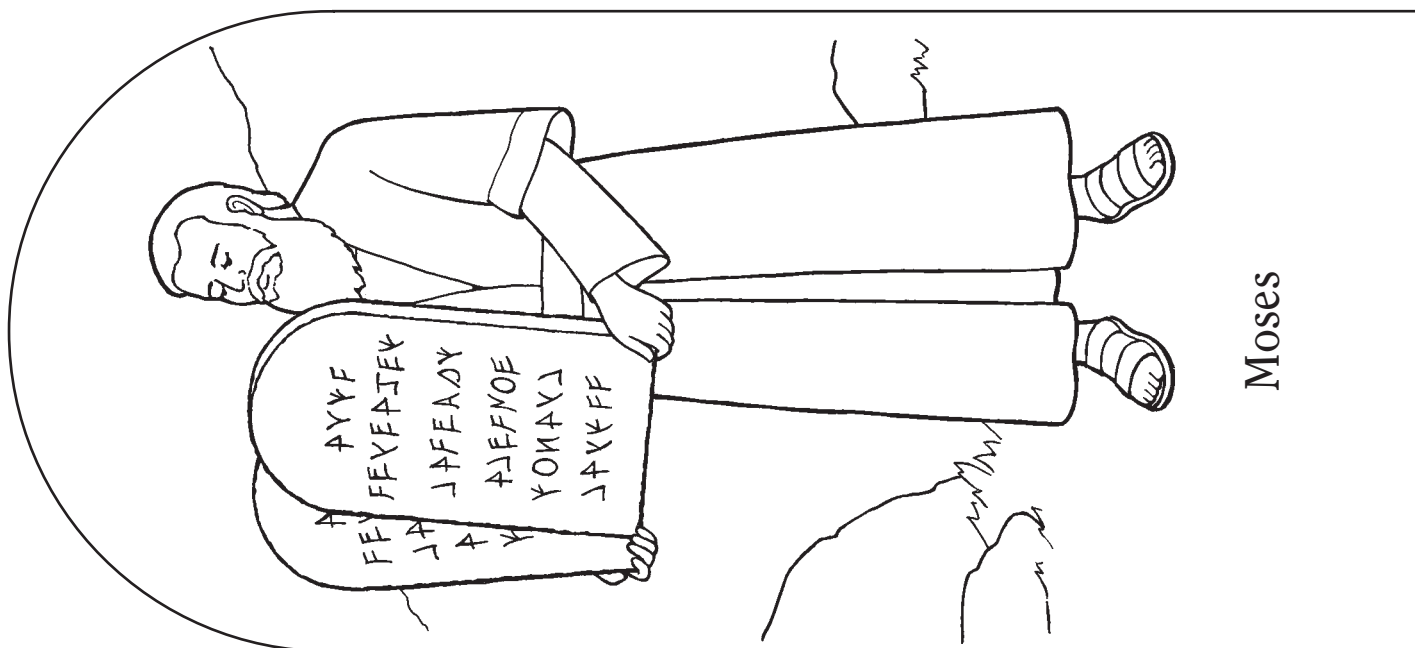

Moses

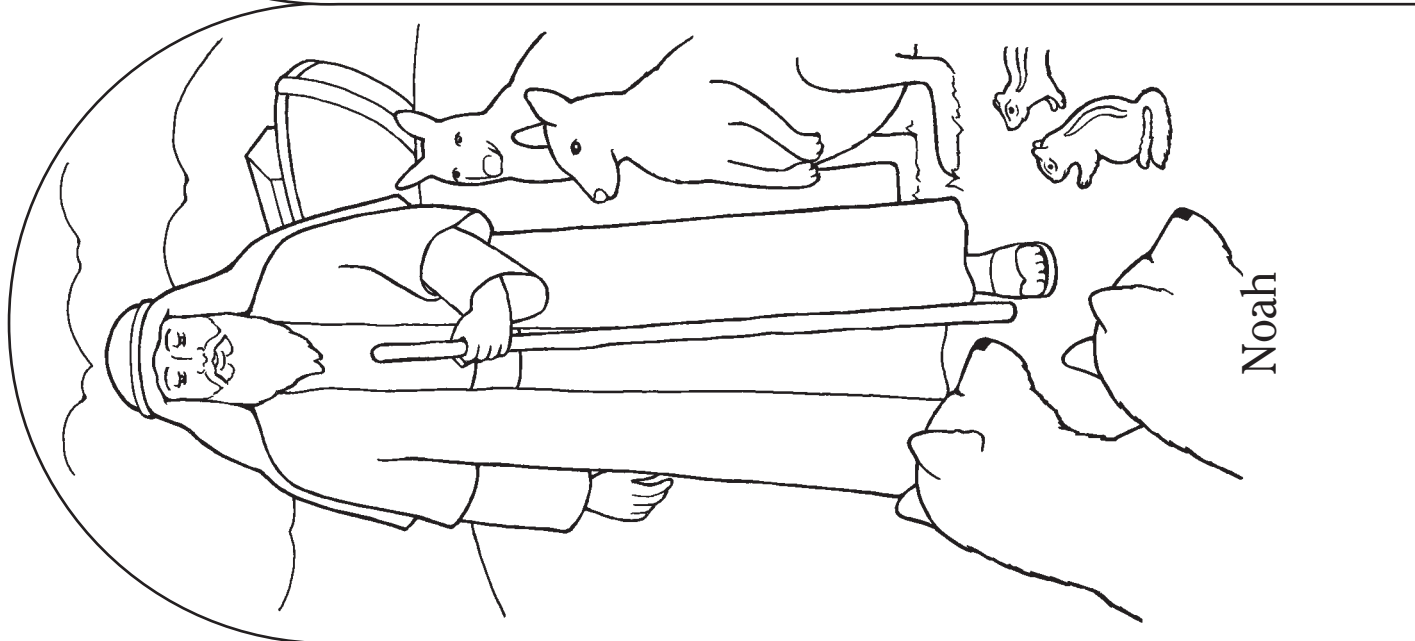

Noah



Adam and Eve



# 24

## I WILL FOLLOW THE PROPHET

### INTRODUCTION FOR THE TEACHER

To prepare yourself spiritually to teach this lesson, please read and ponder the following:

A prophet is a man who has been called by God to speak for Him. Prophets receive God's word by revelation and are then commanded to preach to the people (see Amos 3:7; 1 Nephi 22:2; D&C 1:38; Bible Dictionary, "Prophet," 754). We are blessed to be led by living prophets. Like the prophets of old, prophets today testify of Jesus Christ and teach His gospel. Their teachings are the mind and will of the Lord.

### PREPARATION

Bring a picture of the current President of the Church, if available.

### LEARNING ACTIVITIES

Begin with a gathering activity. For ideas, see page 3.

*Prayer* Invite a child to give the opening prayer.

*Game* Invite the children to play "follow the leader" with you. Choose a child to walk, clap, or do some other action. Tell the other children to follow the first child, doing what he or she does. Continue until each child who wants a turn to be the leader has had one. Ask the children to follow you to the lesson area, and have them sit down.

*Doctrinal Instruction* Tell the children that we have a special leader to follow, our prophet. Explain that a prophet is a man who speaks with God—God tells the prophet what we should do. Tell the children that if we follow the prophet, we will be happy and Heavenly Father will bless us. Explain that to follow the prophet means to do the things he tells us to do.

*Pictures* Show the picture of Joseph Smith (page 102). Say, "This is the Prophet Joseph Smith. Heavenly Father and Jesus talked to Joseph Smith." Hand the picture to a child to hold. Tell the children one thing the Prophet Joseph Smith taught us to do, such as read the scriptures. Have the children pretend to read the scriptures, and invite them to say, "Follow the prophet." Hand the picture to another child and repeat the activity, acting out something else the Prophet taught, such as praying, eating good foods, and so on. After each action, have the children say, "Follow the prophet." Continue until each child has had a chance to hold the picture.

Show a picture of the current President of the Church, if available. Tell the children his name and some of the things he has taught us to do. Explain that when we do these things, we will be blessed.

*Role Play* Invite the children to act out ways we can follow the prophet.



### TEACHING TIPS

*Introduction for the teacher:* Before preparing a lesson, take a moment to prepare yourself spiritually. For example, you can read the introduction at the beginning of the lesson, including the scriptures listed. Studying the doctrines in the lesson can help you be receptive to the promptings of the Spirit as you prepare the lesson and as you teach it to the children. (See *Teaching, No Greater Call*, 14.)

**Song** Invite the children to march around the room with you as you sing or say the words to the chorus of “Follow the Prophet” (*Children’s Songbook*, 111):

Follow the prophet, follow the prophet,  
Follow the prophet; don’t go astray.  
Follow the prophet, follow the prophet,  
Follow the prophet; he knows the way.

Invite the children to sing with you. Repeat, allowing the children to take turns leading the marching. Explain that to go astray means to do wrong things.

**Conclusion** Tell the children that you know that when we follow the prophet, we will be blessed. Have the children say, “I will follow the prophet,” a few words at a time.

**Prayer** Invite a child to give the closing prayer.

### OPTIONAL ACTIVITIES

**PREPARATION** *For the figures activity and the guessing game:* Copy and cut out the figures on page 103. Color if desired. Fold along the dotted lines to make stand-up figures.

*For the coloring activity:* Copy and cut out the figures on page 103 for each child to color.

**Figures** Tell the children that you are going to help them learn about some prophets who lived long ago. Place the four stand-up figures on the floor or on a table. Have the children take turns choosing one of the figures. Tell the children the prophet’s name and read the caption. Invite the children to repeat a key word from the caption, such as “pray,” “baptized,” “obey,” and “scriptures.” Repeat until each child who wants a turn has had one.

**Guessing Game** Have the children cover their eyes or turn their backs while you put the stand-up figures somewhere in the room. Make sure they are easily seen. Ask the children to look for the figures. When they find one, have them bring it back to the lesson area. Tell the children the prophet’s name and read the caption to them. This activity is especially appropriate for older children.

**Coloring** Let the children color a copy of the figures on page 103. When they are finished, fold along the dotted lines to make stand-up figures for the children to take home. If you don’t have time to make the figures during the nursery class, ask the children’s parents to do it at home.

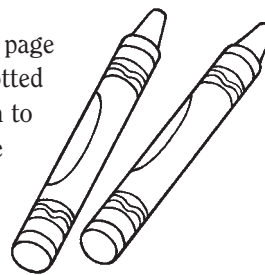

### TEACHING TIPS

**Optional activities** are provided for you to add to the lesson if desired. If the supplies needed are not available to you, you may substitute something similar.

**Figures:** The children might also enjoy hearing stories about these prophets. Use Daniel 6:4–23 (Daniel in the lions’ den), Matthew 3:13–16 (John the Baptist baptizes Jesus), Helaman 13:2–4; 16:1–3 (Samuel the Lamanite), and the introduction to the Book of Mormon (Joseph Smith translates the gold plates). Remember to keep the stories very simple and brief.

**Guessing game:** Young children are naturally curious and might not cover their eyes or turn their backs. They will still enjoy watching you hide the figures and then running to get them when you tell them to.

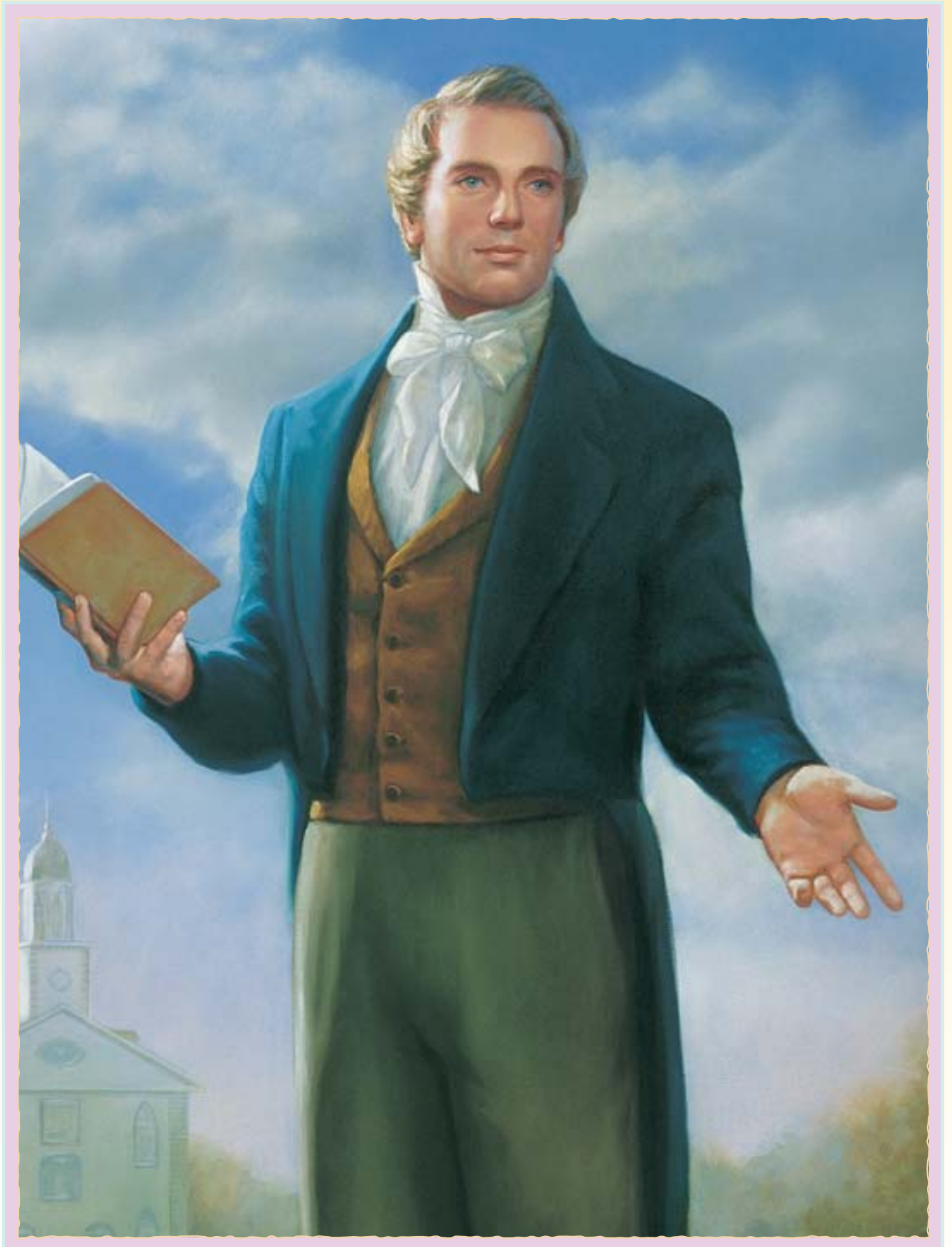

I will follow the prophet.

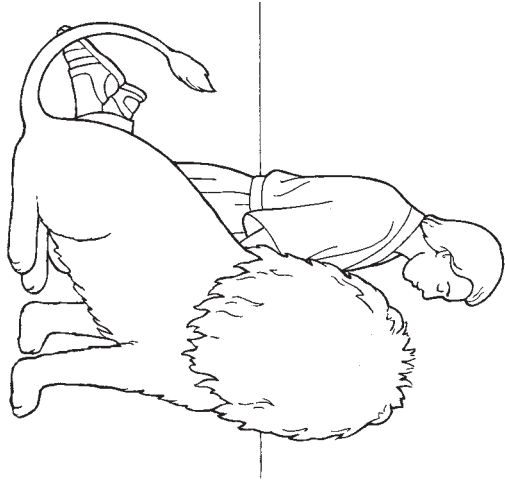

I will follow the prophet.

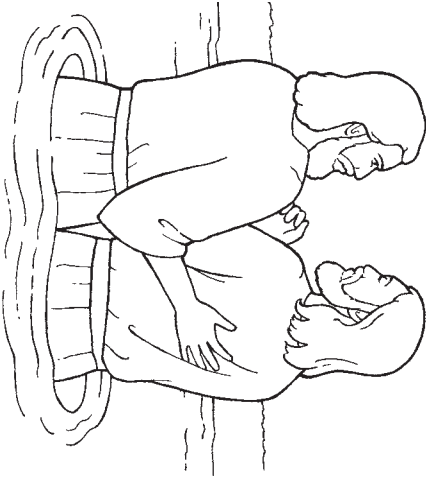

Daniel taught us that we should pray.

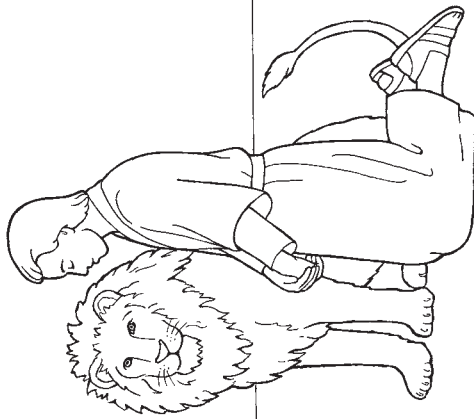

John the Baptist taught us to be baptized.

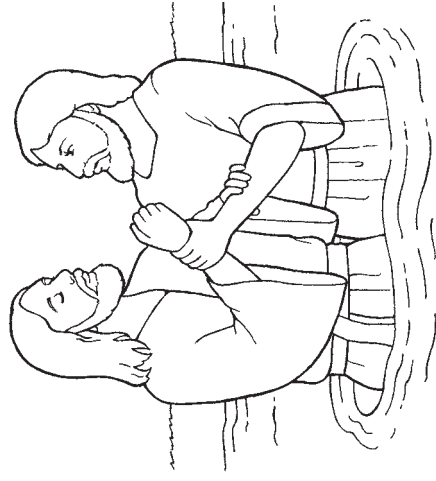

I will follow the prophet.

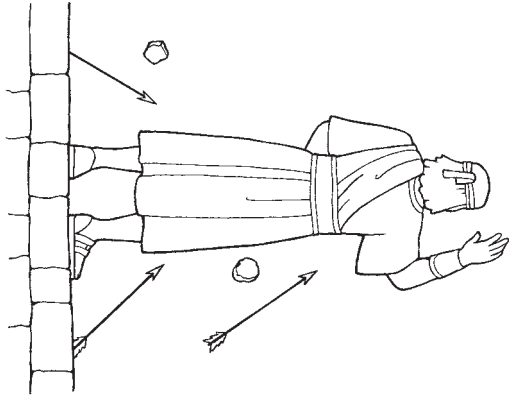

Samuel the Lamanite taught us to obey Heavenly Father.

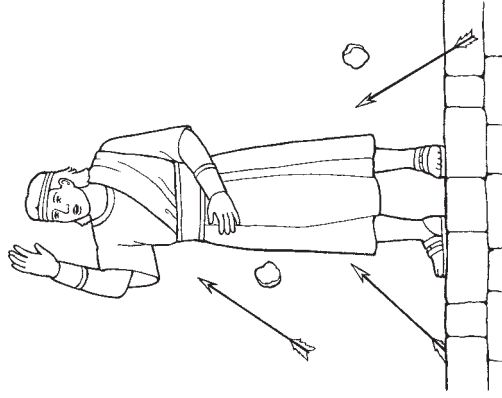

I will follow the prophet.

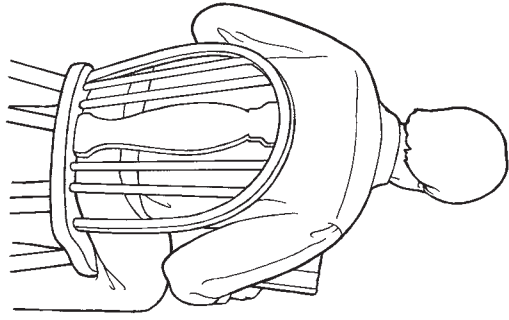

Joseph Smith taught us to read the scriptures.



# 25

## I BELONG TO THE CHURCH OF JESUS CHRIST OF LATTER-DAY SAINTS

### INTRODUCTION FOR THE TEACHER

To prepare yourself spiritually to teach this lesson, please read and ponder the following:

When Jesus Christ was on the earth, He established His Church. After Christ's Crucifixion and the deaths of the Apostles, the fulness of the gospel was lost, and the true Church was taken from the earth. Through the Prophet Joseph Smith, the fulness of the gospel has been restored, and the true Church of Jesus Christ is on the earth again. (See D&C 1:15–30; Joseph Smith—History 1:68–72.)

### PREPARATION

- Bring a copy of the scriptures. Mark D&C 115:4 so that you can turn to it easily.
- Bring a picture of the current President of the Church, if available.

### LEARNING ACTIVITIES

Begin with a gathering activity. For ideas, see page 3.

*Prayer* Invite a child to give the opening prayer.

*Picture* Display the picture on page 106. Tell the children that this is a picture of Jesus Christ and we belong to His Church. Point to the picture and ask, “Who is this?”

Answer: “Jesus Christ.”

*Scripture* Tell the children that Jesus told us the name of the Church in the scriptures. Open the scriptures and read D&C 115:4: “For thus shall my church be called in the last days, even The Church of Jesus Christ of Latter-day Saints.” Invite the children to repeat the name of the Church with you, a few words at a time.

Hold up your copy of the scriptures. Tell the children that Jesus tells us what He wants us to know in the scriptures and that in the Church of Jesus Christ we have scriptures. Have the children hold their hands open as if reading the scriptures. Invite them to say “the Church of Jesus Christ.”

Explain that Jesus speaks to His prophets and that in the Church of Jesus Christ we have prophets. Invite the children to say “the Church of Jesus Christ.” Show a picture of the current President of the Church. Explain that he is our prophet today. Invite the children to say his name with you.

*Song* Invite the children to march with you around the room while you sing or say the following words to “The Church of Jesus Christ” (*Children’s Songbook*, 77):

I belong to The Church of Jesus Christ of Latter-day Saints.  
I know who I am.  
I know God’s plan.  
I’ll follow him in faith.



### TEACHING TIPS

*Pictures:* To teach with pictures, first tell the children what or who is in the picture. Point out details in the picture to engage the children’s attention. Then invite them to repeat one or two words with you. As the children hear and say these words while looking at the picture, they begin to learn the vocabulary of the gospel.

*Movement:* Nursery-age children are very active. Use activities that include clapping, marching, and walking to help the children stay engaged.

*Conclusion* Briefly share your testimony that we belong to the true Church of Jesus Christ.

*Prayer* Invite a child to give the closing prayer.

### OPTIONAL ACTIVITIES

*PREPARATION* For the coloring activity and the matching game: Copy the illustration on page 107 for each child to color. Bring small bits of paper or something similar for the children to use as markers for the matching game; bring enough for each child to have three markers.

*Coloring* Let the children color a copy of page 107. While they are coloring, review the principles taught in the lesson. Point out details in the pictures and explain to the children what they are coloring. Read the words on the illustration to them.

*Matching Game* Give each child three bits of paper. Display the illustration on page 107. Point to the drawing of Jesus and say, "This is a picture of Jesus Christ. We belong to His Church." Invite the children to put a bit of paper on the picture of Jesus on their copies.

Then point to the picture of the prophet and read the caption. Have the children say "prophet" and put a bit of paper on their drawing. Repeat for the drawing of the scriptures. Then have the children say with you, "I belong to The Church of Jesus Christ of Latter-day Saints," a few words at a time.

*Review* Choose an activity from lesson 23 and one from lesson 24 to help the children review what they have learned about the scriptures and prophets. After doing these activities, remind the children that in the Church of Jesus Christ we have scriptures and prophets.

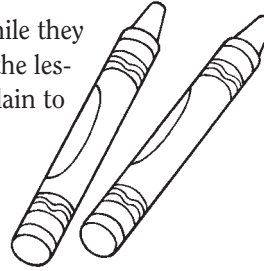

### TEACHING TIPS

*Coloring:* Not all children enjoy coloring. Some may make only a mark or two on the page. The purpose of the coloring activities in these lessons is to give the children a visual representation of the lesson that they can hold and take home. It is not important that they color the illustration skillfully.

*Review:* Children learn from repetition. Repeat stories or other activities they seem to enjoy. You can do this at any time during the nursery class, such as during snack time or while the children are waiting for their parents.

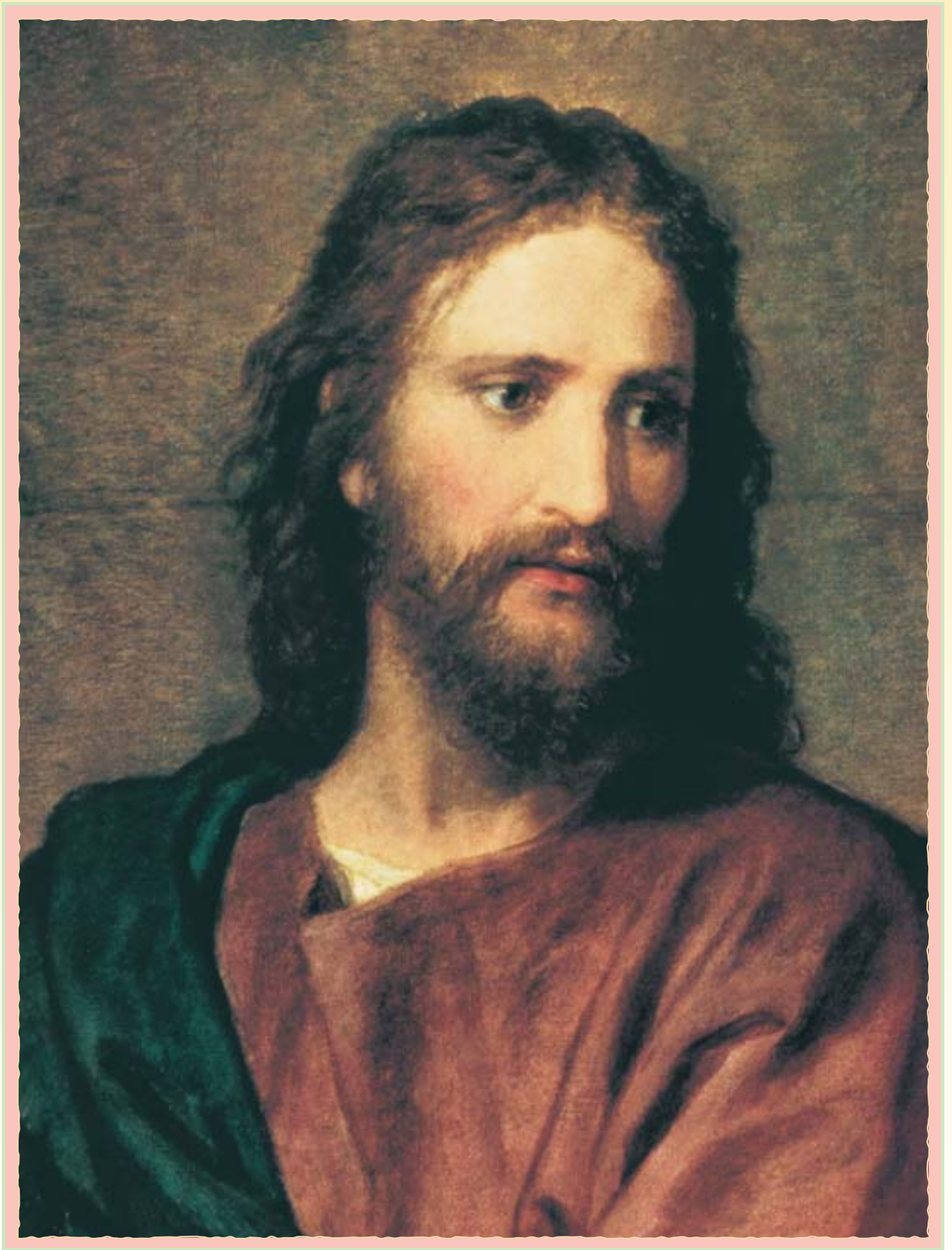

# I Belong to The Church of Jesus Christ of Latter-day Saints

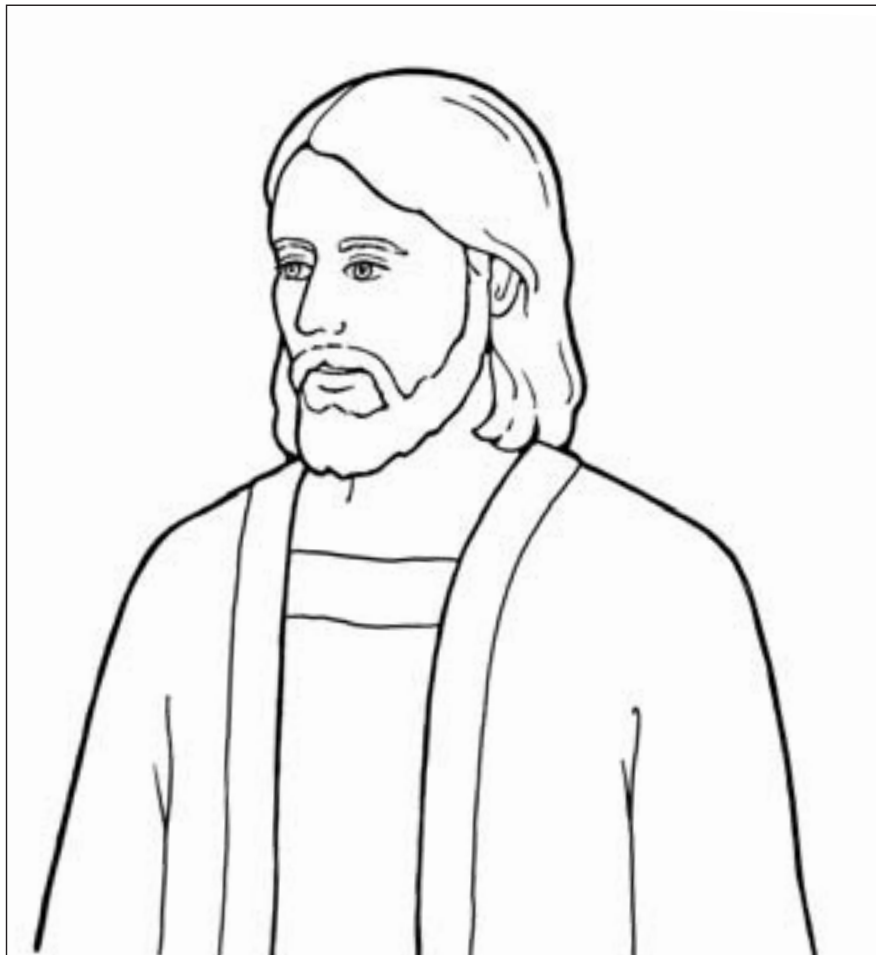

The Church of Jesus Christ  
has prophets.

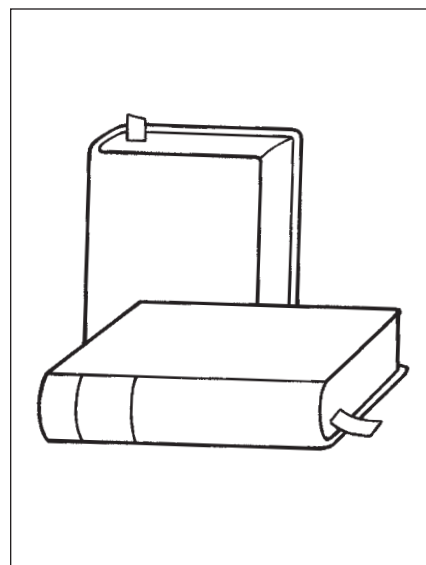

The Church of Jesus Christ  
has scriptures.



## INTRODUCTION FOR THE TEACHER

To prepare yourself spiritually to teach this lesson, please read and ponder the following:

Jesus Christ was baptized to show “unto the Father that he would be obedient unto him in keeping his commandments” and to set an example for us (see 2 Nephi 31:7, 9; see also Matthew 3:13–17). When we are baptized, we also show that we are willing to follow the Savior and obey His commandments. After Jesus was baptized, “the Holy Ghost descended upon him” (2 Nephi 31:8). After we are baptized, we are given the gift of the Holy Ghost through the ordinance of confirmation. This means that we can have the constant companionship of the Holy Ghost if we keep the commandments.

## LEARNING ACTIVITIES

Begin with a gathering activity. For ideas, see page 3.

*Prayer* Invite a child to give the opening prayer.

*Picture* Show the picture of Jesus Christ being baptized (page 110). Point out details in the picture (Jesus, the water, John the Baptist, and so on). Explain that Jesus was baptized because He loves Heavenly Father and wants to obey Him. Invite the children to say “Jesus” and “baptized” with you.

*Poem* Point to different parts of the picture while you recite the words to the first verse of “Baptism” (*Children’s Songbook*, 100–101). Invite the children to point with you.

Jesus came to John the Baptist, (*point to Jesus, then to John*)

In Judea long ago,

And was baptized by immersion

In the River Jordan’s flow. (*point to the water*)

You may want to explain that “immersion” means that Jesus went all the way under the water when He was baptized.

*Picture* Show the picture of the girl being baptized (page 110) and point out the similarities between the two pictures. Tell the children that they can be baptized, just like Jesus was, when they are eight years old. Hold up eight fingers, four on each hand, and count them. Repeat, and invite the children to do it with you. Emphasize that being baptized is one way we can follow Jesus; when we are baptized we show that we love Heavenly Father and want to obey Him.

*Illustrations* Show the illustrations on page 111. Talk to the children about what is happening in the illustrations. Explain that after we are baptized, we are confirmed. Invite the children to say “confirmed.” Tell them this means that men who hold the priesthood put their hands on our head to give us the gift of the Holy Ghost.

TEACHING  
TIPS

*Pictures:* When there are two pictures on the same page, you can help the children focus on one picture by covering the other one.

*Young children:* Some of the children, especially the younger ones, may not understand all of the concepts taught in these lessons. However, they are learning something each week, and you are helping them feel the Spirit and become familiar with gospel-related words and phrases.

*Conclusion* Invite the children to say, “I will be baptized and confirmed,” a few words at a time. Briefly tell the children how you felt when you were baptized and confirmed.

*Prayer* Invite a child to give the closing prayer.

## OPTIONAL ACTIVITIES

*PREPARATION* *For the scripture activity:* Bring a copy of the Book of Mormon. Mark 3 Nephi 12:1 so that you can turn to it easily.

*For the guessing game:* Copy the illustrations on page 111 and color them if desired. Fold the page in half so that the baptism illustration is showing on one side and the confirmation illustration is showing on the other.

*For the coloring activity:* Copy the illustrations on page 111 for each child to color.

*Scripture* Tell the children that Jesus Christ tells us in the scriptures that He wants us to be baptized. Open the Book of Mormon to 3 Nephi 12:1 and say, “Jesus said, ‘Believe in me and be baptized.’ ” Invite the children to repeat the phrase with you, a few words at a time. Remind them that they can be baptized when they are eight years old.

*Guessing Game* Show the children your copy of the baptism illustration, read the caption, and invite the children to say “baptized.” Turn the page over, and repeat for the confirmation illustration.

Hide the illustrations behind your back. Then show the children one side of the page, and ask, “Is this boy being baptized or confirmed?” Invite the children to say the answer with you. Hide the illustrations behind your back again and repeat the activity as long as the children are interested. This activity is especially appropriate for older children.

*Coloring* Let the children color a copy of the illustrations on page 111. While they are coloring, review the principles taught in the lesson. Point out details in the pictures, read the captions to the children, and explain to them what they are coloring.

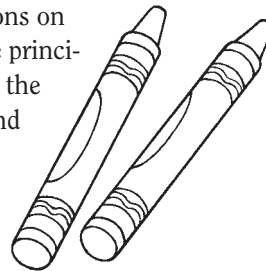

## TEACHING TIPS

*Making copies:* If you don't have access to a copy machine, you can place a plain sheet of paper over the illustrations and trace them with a pencil or pen. Don't worry about tracing all of the details; just trace the outlines and enough detail to identify the illustrations.

*Coloring:* “Encourage [the children] to show their pictures to their families. This will help them remember what they have learned. It will also give parents an opportunity to discuss gospel principles with their children” (*Teaching, No Greater Call*, 167).



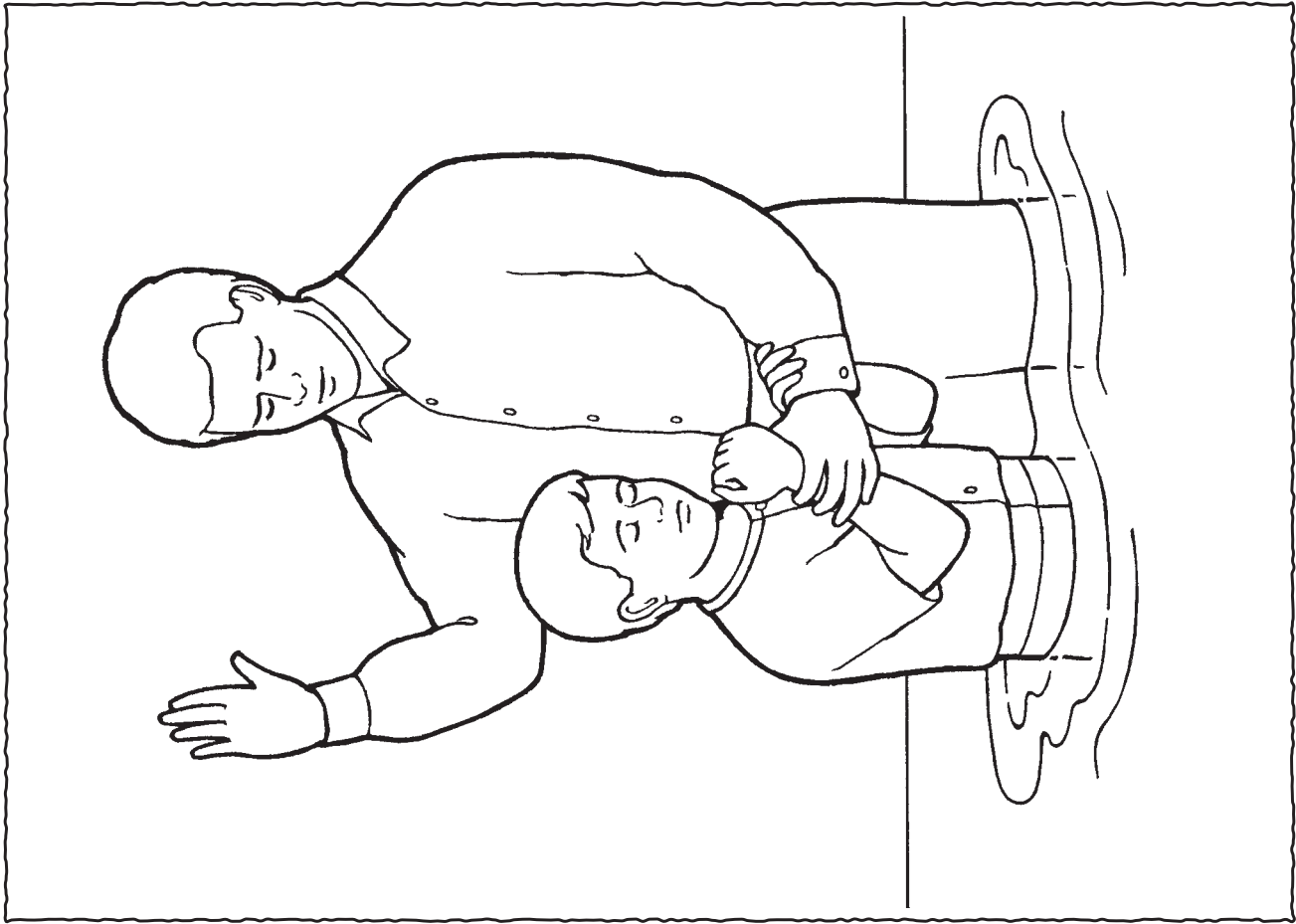

I Will Be Baptized

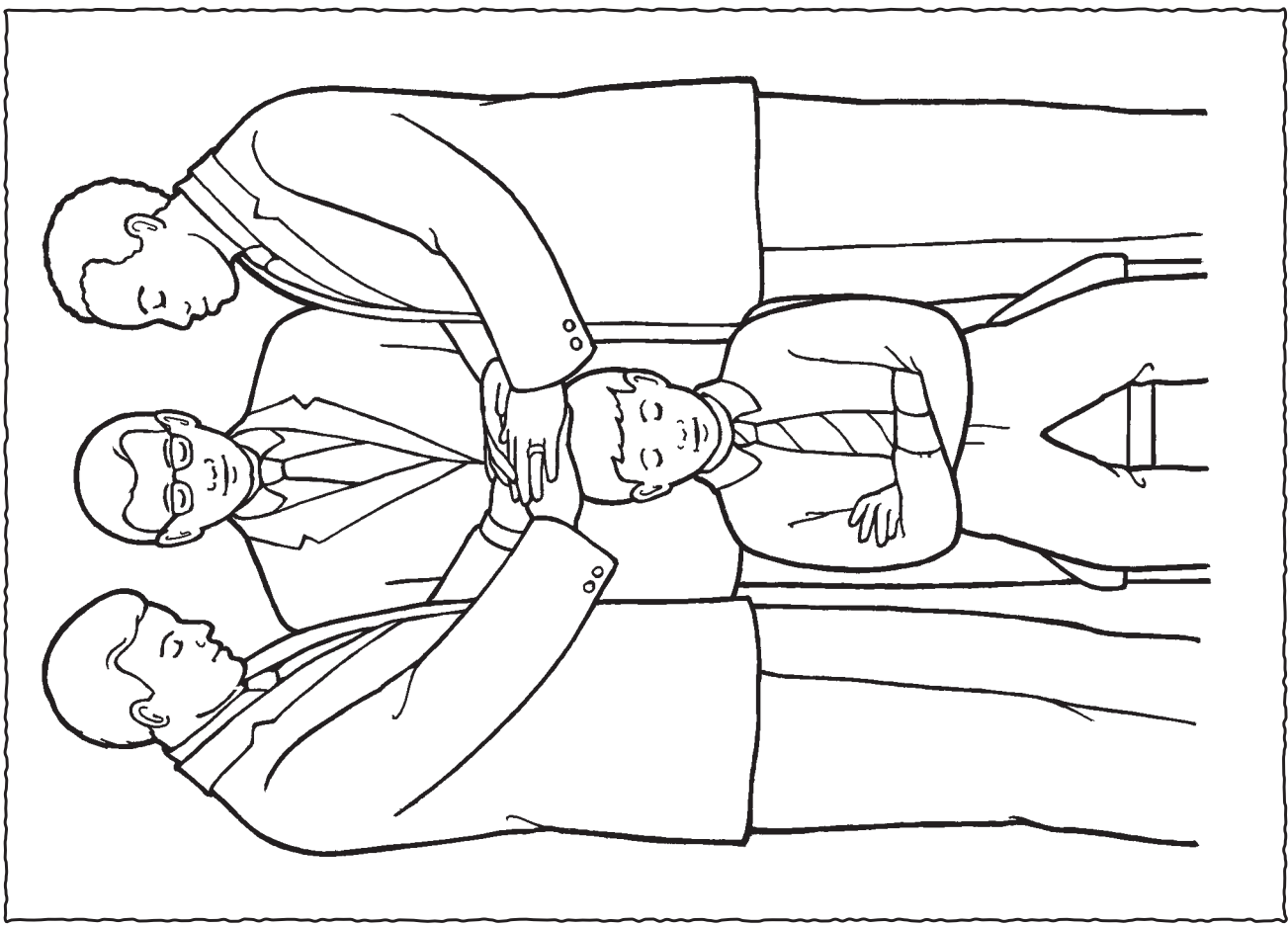

I Will Be Confirmed

# 27

## THE SACRAMENT HELPS ME THINK ABOUT JESUS CHRIST

### INTRODUCTION FOR THE TEACHER

To prepare yourself spiritually to teach this lesson, please read and ponder the following:

On the night before His death on the cross, Jesus Christ gave the sacrament to His Apostles and said, “This do in remembrance of me” (see Luke 22:19–20). After His Resurrection, He did the same among the Nephites (see 3 Nephi 18:1–11). Today we also partake of the sacrament in remembrance of the Savior’s sacrifice for us. We witness to God that we will always remember Jesus Christ and keep His commandments. (See D&C 20:77, 79.)

### PREPARATION

- With the permission of the bishop or branch president, bring empty sacrament trays to nursery.
- Bring a copy of the Bible. Mark Luke 22:19 so that you can turn to it easily. Also mark page 106 in this manual.

### LEARNING ACTIVITIES

Begin with a gathering activity. For ideas, see page 3.

**Prayer** Invite a child to give the opening prayer.

**Song** Show the picture of Jesus on page 106 while you sing the first line of “Reverently, Quietly” (*Children’s Songbook*, 26):  
Reverently, quietly, lovingly we think of thee. (*point to the picture of Jesus*)

Repeat a few times to help set a reverent atmosphere. Invite the children to sing with you.

**Scripture** Tell the children that every Sunday we do something very special to remember Jesus—during sacrament meeting we eat a small piece of bread and drink a small cup of water. Tell them that this is called the sacrament. Invite the children to say “sacrament.” Tell the children that we learn in the scriptures that Jesus wants us to take the sacrament to remember Him. Open the Bible to Luke 22:19 and say, “Jesus said, ‘This do in remembrance of me.’ ”

**Picture** Show the picture of a deacon passing the sacrament (page 114). Point out details in the picture, such as the deacon and the people sitting quietly. Let the children hold the sacrament trays you brought while you explain in simple terms what happens during the administration of the sacrament—we listen quietly while the sacrament is blessed; we take one piece of bread; we drink the water and put the cup back in the tray; and we think about Jesus.

**Activity Verse** Recite the following activity verse, and invite the children to join you:  
Quietly I eat the bread (*pretend to eat bread*)  
And drink the water too. (*pretend to drink water*)  
I fold my arms and think of Jesus— (*fold arms*)  
That’s what I should do. (*nod head up and down*)  
[M. W. Verbica, “The Sacrament,” *Friend*, Feb. 1995, 17]



### TEACHING TIPS

**Reverence:** Use a quiet voice and respectful manner to help the children understand that the sacrament is sacred.

**Holding objects:** Young children think simply and literally. They do not understand abstract ideas. Giving them objects to handle that are related to the lesson helps them learn. Make sure that they handle the sacrament trays with reverence and respect. There should not be any bread or water in the trays for this activity.

**Conclusion** Show the picture of Jesus on page 106. Ask the children, “Who should we think about when we take the sacrament?” Invite the children to say, “Jesus.”

**Prayer** Invite a child to give the closing prayer.

## OPTIONAL ACTIVITIES

**PREPARATION** *For the guest activity:* Arrange for an Aaronic Priesthood holder to come to the nursery class and talk about how he helps administer the sacrament.

*For the role play and the game:* Copy the cards on page 115. Color the cards, if desired, and cut them out.

*For the book:* Copy and cut out the cards on page 115 for each child. Bring some yarn or string.

**Guest** Introduce your guest to the children. Explain that he has the priesthood. Ask him to talk briefly about how he prepares, blesses, or passes the sacrament. Invite him to share his feelings about the sacrament.

**Role Play** Hold up the cards you prepared, one at a time. Read the caption and have the children pretend to do what is shown in the drawing (for the first three cards only). For example, have them fold their arms and bow their heads and reverently pretend to take the bread and the water. Praise them for their efforts each time. When you hold up the drawing of Jesus, ask the children, “Who should we think about when we take the sacrament?”

**Game** Place the cards you prepared face down on the floor or on a table. Invite one of the children to turn over one of the cards. Read the caption on the card. Repeat until each child who wants a turn has had one.

**Book** Give each child the four cards you prepared for them. Punch a hole in the corner of each card. Thread some yarn or string through the holes, and tie the string to make a small book for each child. Then read the book to the children.



## TEACHING TIPS

**Prayer:** You may want to give the opening or closing prayer yourself occasionally to show the children how to pray. They learn as much from your example as they do from what you say to them.

**Reverence:** When you ask the children who we should think about during the sacrament, some of them might shout the answer. If they do, gently teach them to use Jesus Christ's name with reverence.

**Adapt activities** to meet your needs and resources. For example, if you don't have yarn or string to use for this activity, you can bind the cards together in some other way. Or you could let the children color the illustrations without making them into a book.



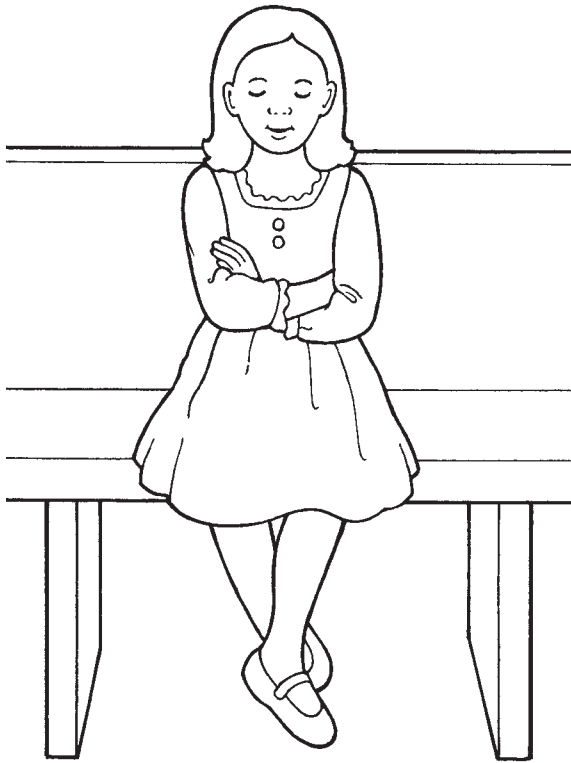

I can listen while the sacrament prayers are said.

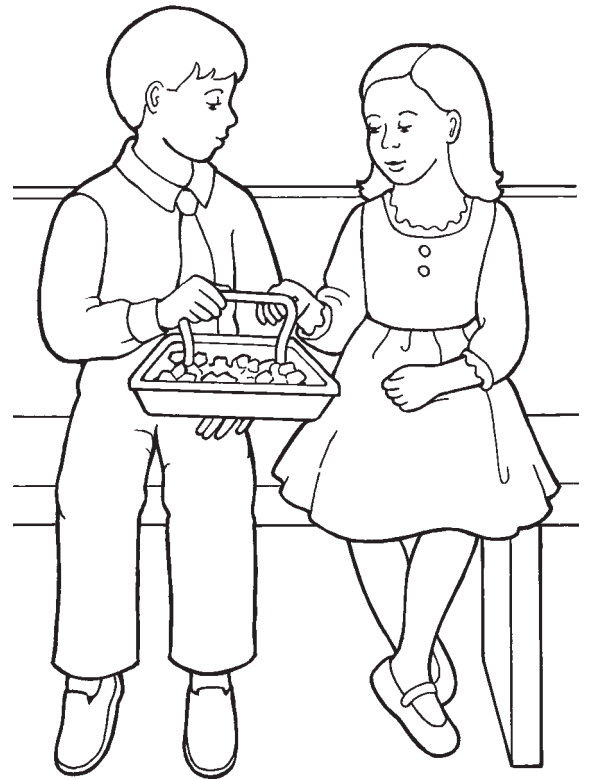

I can think of Jesus when I eat the bread.

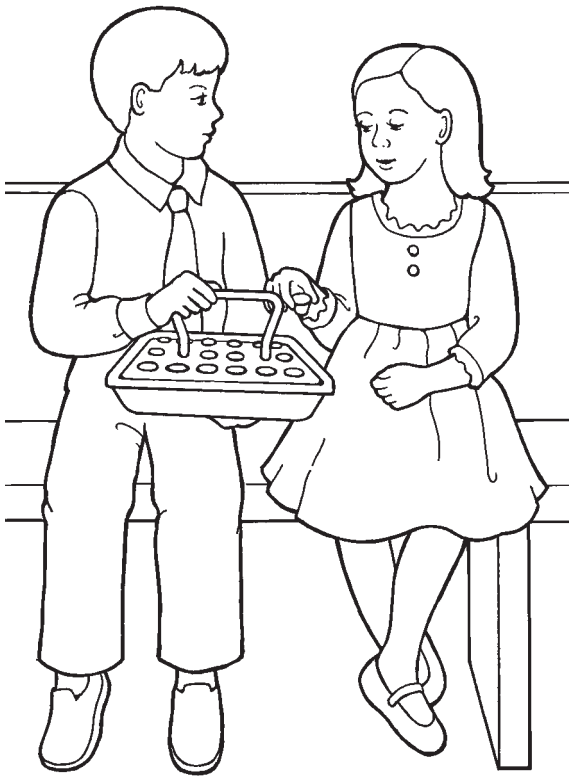

I can think of Jesus when I drink the water.



The sacrament helps me think about Jesus.



# HEAVENLY FATHER BLESSES ME THROUGH THE PRIESTHOOD

## INTRODUCTION FOR THE TEACHER

To prepare yourself spiritually to teach this lesson, please read and ponder the following:

The priesthood is the power and authority of God. God gives this authority to worthy male members of the Church ages 12 and older so that they can act in His name to bless others. The ordinances of the gospel, such as baptism and confirmation, the sacrament, and others, are performed by the authority of the priesthood (see D&C 13; 20:73–79; 84:19–22). All members of the Church benefit from the priesthood.

## PREPARATION

Mark pages 26 and 114 in this manual so that you can turn to them easily.

## LEARNING ACTIVITIES

Begin with a gathering activity. For ideas, see page 3.

*Prayer* Invite a child to give the opening prayer.

*Doctrinal Instruction* Tell the children that the priesthood is God’s power; God gives the priesthood to older boys and men so that they can bless their families and others. Have the children say “priesthood.” (*Note:* During this lesson, be sensitive to the feelings of children in the nursery who do not have a father in their homes or whose fathers do not hold the priesthood.)

*Pictures* Show the picture on page 118 and invite the children to pretend to hold a baby. Explain that babies can be blessed and given a name by men who have the priesthood. Invite the children to say “priesthood.”

Show the illustration on page 119 of a blessing for the sick. Tell the children that a person who has the priesthood can bless those who are sick so that they can feel better. Turn to the picture on page 26. Point to Jesus and explain that in this picture Jesus is blessing someone who is blind. Invite the children to say “priesthood.”

Show the picture on page 114. Remind the children that we take the sacrament each Sunday. Explain that it is prepared, blessed, and passed by those who have the priesthood. Invite the children to say “priesthood.”

*Song* Invite the children to hold hands and walk in a circle while you sing or say the following words from “Love Is Spoken Here” (*Children’s Songbook*, 190):

Mine is a home where every hour is blessed by the strength of  
priesthood power.

*Conclusion* Share your testimony that Heavenly Father blesses us through the priesthood.

*Prayer* Invite a child to give the closing prayer.



## TEACHING TIPS

**Doctrinal instruction:** This section is intended to help the children gain a very basic understanding of the gospel. Some of them may not understand everything you say, but they will become familiar with the language of the gospel and build a foundation for things they will learn later in life.

**Young children** have varied language abilities (see *Teaching, No Greater Call*, 110–11). To help younger children repeat words from the lesson, in a gentle tone say something like, “Can you say *priesthood*? Say *priesthood* with me,” and wait for a response. If the child does not respond, lovingly repeat the invitation, but do not pressure him or her. Even by only listening, children can learn from the lesson.

## OPTIONAL ACTIVITIES

**PREPARATION** *For the guest activity:* Arrange for a father who blessed his baby recently to bring his baby to the nursery class and talk about his experience.  
*For the flip book:* Copy the illustration on page 119. Color if desired.  
Cut along the solid lines and fold along the dotted line.

**Activity Verses** Recite any or all of the following activity verses and invite the children to join you. After each verse, remind the children that the priesthood blesses our lives.

*Baby blessing (display the picture on page 118):*

Daddy holds the baby (*pretend to hold baby in arms*)  
So very tenderly  
To bless and name through priesthood power.  
He loves our family! (*hug self*)

*Blessing for the sick (point to the illustration on page 119):*

When I am sick, I can be blessed (*point to self*)  
By righteous priesthood men.  
I feel at peace, and I have faith (*put hands on heart*)  
That I'll be well again.

*Sacrament (display the picture on page 114):*

Quietly I eat the bread (*pretend to eat bread*)  
And drink the water too. (*pretend to drink water*)  
I fold my arms and think of Jesus— (*fold arms*)  
That's what I should do. (*nod head up and down*)  
[M. W. Verbica, "The Sacrament," *Friend*, Feb. 1995, 17]

**Guest** Introduce your guest to the children. Explain to them that he has the priesthood and that he used the priesthood to bless his baby. Ask the father questions such as, "Do you have the priesthood?" "What is your baby's name?" "What did you say when you blessed your baby?" "How will you use the priesthood to bless your baby as he [or she] grows older?"

**Flip Book** Show the children the flip book you prepared. Lift the first flap, read the caption, and have the children say it with you. Repeat for each flap.

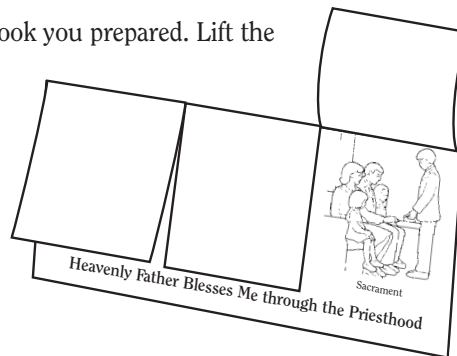

## TEACHING TIPS

**Review:** Children love stories, songs, pictures, and activities that they have seen and heard before. Sing songs or do activity verses from this lesson or previous lessons at any time during the nursery class. This review will help them remember the gospel principles you have taught.



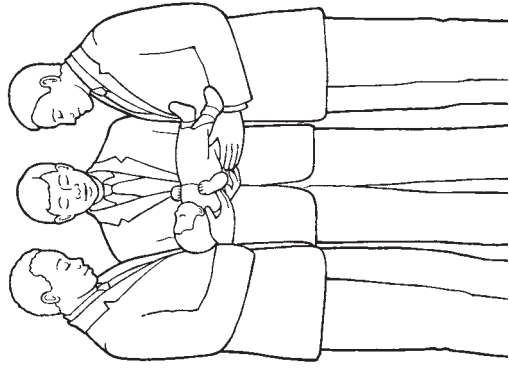

Baby Blessing

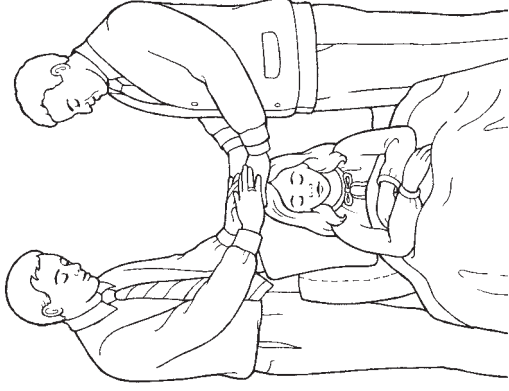

Blessing for the Sick

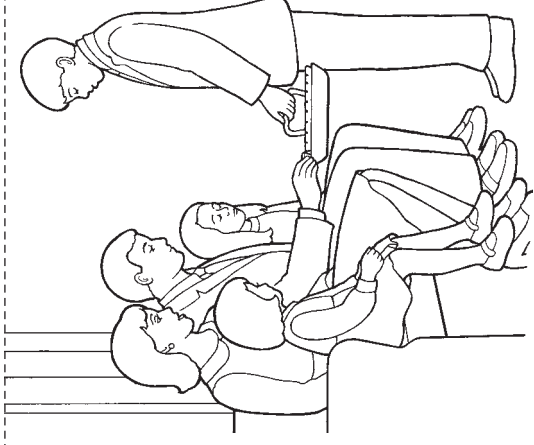

Sacrament

# Heavenly Father Blesses Me through the Priesthood

# 29

## JESUS CHRIST WAS RESURRECTED (EASTER)

### INTRODUCTION FOR THE TEACHER

To prepare yourself spiritually to teach this lesson, please read and ponder the following:

Because of the Fall of Adam and Eve, everyone will experience physical death. When we die, our spirits and our bodies are separated. When Jesus Christ was resurrected, His body and His spirit were reunited, never to be separated again. Because of the Atonement of Jesus Christ, everyone will be resurrected (see 1 Corinthians 15:22; Alma 11:42–45). An understanding and testimony of the Resurrection give us joy and hope (see Isaiah 25:8; Alma 22:14).

### LEARNING ACTIVITIES

Begin with a gathering activity. For ideas, see page 3.

**Prayer** Invite a child to give the opening prayer.

**Story** Show the picture on page 122. Point out details in the picture as you tell the story of Jesus Christ’s Resurrection very simply (see John 19:41–42; 20:1, 11–16). The following is an example:

When Jesus died, His friends were very sad (*have the children make sad faces*). They put Jesus’s body in a tomb, which is like a cave (*point to the tomb in the picture*). A big stone was rolled in front of the door (*have the children pretend to roll a big, heavy stone*). After three days (*have the children hold up three fingers*), two angels rolled the stone away. Jesus had come back to life! (*Point to Jesus in the picture.*) He was resurrected (*help the children say “resurrected”*). Jesus’s friends were very happy! He was alive, and He would never die again!

Mary was one of Jesus’s friends (*point to Mary in the picture*). She was sad when He died. When Jesus was resurrected, Mary was the first person who saw Him. She was very happy because Jesus was alive (*have the children make happy faces*).

Tell the children that because of Jesus, everyone will be resurrected and live forever. Have the children make happy faces again.

**Song** Sing or say the first verse of “Did Jesus Really Live Again?” (*Children’s Songbook*, 64) and do the actions below. Invite the children to join you.

Did Jesus really live again?  
Yes, when the third day came, (*hold up three fingers*)  
He wakened and he left the tomb;  
He called Mary’s name. (*fold arms*)

**Conclusion** Invite the children to say, “Jesus Christ was resurrected,” one or two words at a time. Briefly share with the children your testimony that Jesus Christ was resurrected.

**Prayer** Invite a child to give the closing prayer.



### TEACHING TIPS

**Jesus Christ:** Many cultures have Easter traditions that are fun for children but have little to do with the Resurrection of Jesus Christ. Center this Easter lesson on the Savior, and help the children grow in their love for Him. Teach them to rejoice in the wonderful gifts He has given us, such as the Resurrection and His teachings and perfect example.

**Songs:** Some of the children may not sing with you. Even if they only do the actions or simply watch and listen to you, they can still enjoy the songs and learn from them.

**Testimony:** Express your testimony in a simple, concise way; for example: “I know that Jesus Christ was resurrected.”

## OPTIONAL ACTIVITIES

**PREPARATION** *For the story:* Copy the illustrations on page 123. Color them and mount them on heavier paper, if desired. Cut out each figure and cut out the opening in the tomb door along the dotted line.

*For the coloring activity:* Make a copy of page 123 for each child. Cut out each figure and cut out the opening in the tomb door.

**Song** Invite the children to stand in a circle and hold hands. Sing or say the following words to “Jesus Has Risen” (*Children’s Songbook*, 70) and do the actions below:

Jesus has risen, (*walk in a circle*)

Jesus, our friend.

Joy fills our hearts; (*stop and place hands over heart*)

He lives again.

Repeat as often as the children would like.

**Story** Tell the story of the Resurrection of Jesus Christ again, this time using the illustration you have cut out. Below is an example:

(*Begin with the figure of Jesus standing upright and the stone rolled away from the opening in the tomb.*) When Jesus died, his body

was laid in a tomb (*lay the figure of Jesus in [behind] the tomb*). A large stone was rolled in front of the door (*roll the stone in front of the opening in the tomb*). On the third day two angels came and rolled the stone away (*roll the stone away from the opening*). Jesus was resurrected (*stand the figure of Jesus upright*). His spirit and His body were together again! [See Susan Payson, “Easter Story,” *Friend*, Apr. 1995, 32–33.]



**Coloring** Give the children the illustrations you have cut out for them. Show them how they can use the illustrations to review the story of Jesus’s Resurrection. This activity is especially appropriate for older children.

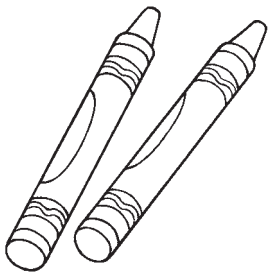

## TEACHING TIPS

*Optional activities* are provided for you to add to the lesson if desired. If the supplies needed are not available to you, you may substitute something similar.

**Stories:** “Young children enjoy having stories repeated. If you are repeating a story, start it and then ask, ‘What happened next?’” (*Teaching, No Greater Call*, 181–82). Invite one of the older children to use the cutouts or the picture on page 122 to tell the story of the Resurrection to the younger children in the nursery class. Offer to help if necessary.

**Activity box:** Consider making an activity box to keep in the nursery. It can contain this coloring activity and other items you make or use for activities. Then you can repeat those activities during future nursery classes to review previous lessons. This review can happen at any time during the nursery class.



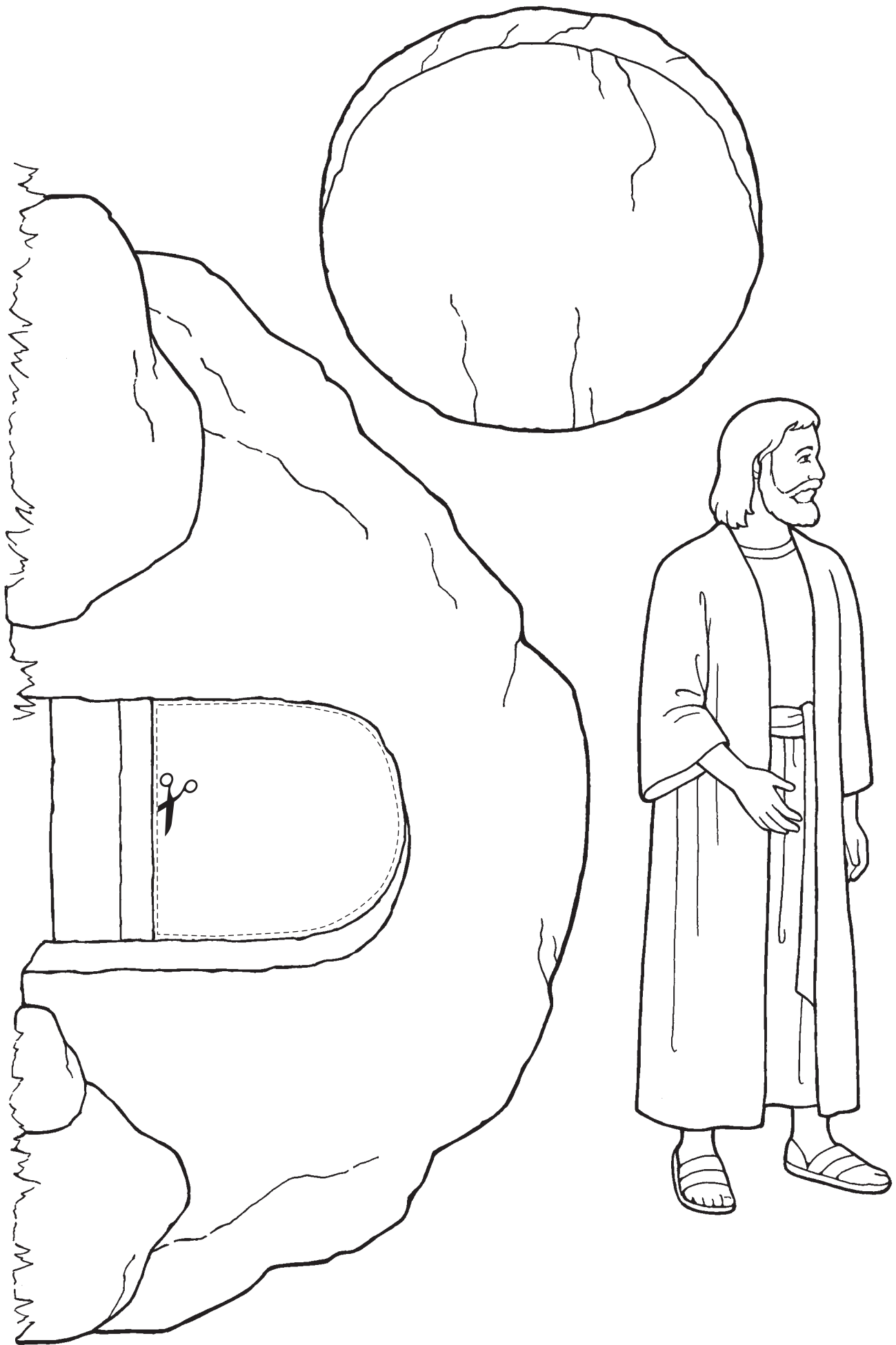



# 30

## JESUS CHRIST IS THE SON OF HEAVENLY FATHER (CHRISTMAS)

### INTRODUCTION FOR THE TEACHER

To prepare yourself spiritually to teach this lesson, please read and ponder the following:

Jesus Christ was born of a mortal mother, Mary, and an immortal father, Heavenly Father. He is literally the Son of God. Because of His great love for us, Heavenly Father sent Jesus Christ to earth to be our Savior and our Exemplar. “God so loved the world, that he gave his only begotten Son, that whosoever believeth in him should not perish, but have everlasting life” (John 3:16).

### PREPARATION

Mark page 106 in this manual so that you can turn to it easily.

### LEARNING ACTIVITIES

Begin with a gathering activity. For ideas, see page 3.

*Prayer* Invite a child to give the opening prayer.

*Picture* Show the picture on page 126. Invite the children to look for the baby in the picture. Tell them His name is Jesus, and invite them to say “Jesus.” Have the children pretend to cradle a baby in their arms.

Point to Mary in the picture and tell the children, “This is Jesus’s mother. Her name is Mary.”

Tell the children that Jesus is the Son of Heavenly Father. Invite the children to repeat “Jesus is the Son of Heavenly Father,” a few words at a time. Tell them that Heavenly Father sent His Son, Jesus Christ, to earth because He loves us.

*Song* Point to the baby Jesus in the picture again. Tell the children you are going to sing a song. Invite them to say, “He sent His Son” when you point to the baby Jesus. Let them practice a few times, and then sing or say the following words to “He Sent His Son” (*Children’s Songbook*, 34–35):

How could the Father tell the world of love and tenderness?  
He sent his Son, (*point to the picture of baby Jesus*)  
a newborn babe, with peace and holiness.

Show the picture of Jesus Christ on page 106. Tell the children that the baby Jesus grew up to be our Savior, Jesus Christ. Invite them to say, “He sent His Son” when you point to the picture of the Savior. Sing or say the following words to “He Sent His Son”:

How could the Father show the world the pathway we should go?  
He sent his son (*point to the picture of the Savior*)  
to walk with men on earth, that we may know.

*Conclusion* Express your gratitude that Heavenly Father sent Jesus Christ. Share your testimony that Jesus Christ is Heavenly Father’s Son.

*Prayer* Invite a child to give the closing prayer.



### TEACHING TIPS

*Jesus Christ:* “Everything we teach should point family members and class members to Christ. . . . Remember this as you prepare and present your lessons” (*Teaching, No Greater Call*, 80).

*Young children:* Watch for signs that can tell you whether the children are paying attention. To help them be attentive, try varying your teaching voice, maintaining eye contact, and varying your teaching methods. (See *Teaching, No Greater Call*, 71–72.)

## OPTIONAL ACTIVITIES

**PREPARATION** *For the stick puppets:* Copy and cut out the illustrations on page 127 for each child. Tape or glue a stick to the back of each illustration to make stick puppets for the children.

*For the scripture activity:* Bring a copy of the Book of Mormon. Mark 3 Nephi 9:15 so that you can turn to it easily.

**Stick Puppets** Give the children the stick puppets you made for them. Briefly retell the story of the birth of Jesus Christ in your own words (see Luke 2:4–16). Invite the children to hold up their stick puppets at appropriate times during the story. This activity is especially appropriate for older children.

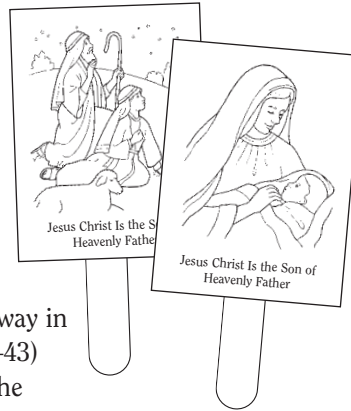

**Song** Sing or say the following words to “Away in a Manger” (*Children’s Songbook*, 42–43) and improvise actions suggested by the words. Invite the children to join you.

Away in a manger, no crib for his bed,  
The little Lord Jesus laid down his sweet head;  
The stars in the heavens looked down where he lay,  
The little Lord Jesus, asleep on the hay.

**Activity Verse** Recite the following activity verse, and invite the children to join you:  
A baby in a manger, (*rock arms as if cradling a baby*)  
A loving mother near,  
A star shines in the heavens, (*point to the sky*)  
The Son of God is here! (*fold arms*)

**Scripture** Tell the children that Jesus told us in the scriptures that He is the Son of God, our Heavenly Father. Open the Book of Mormon to 3 Nephi 9:15 and read, “Behold, I am Jesus Christ the Son of God.” Invite the children to say “the Son of God” with you.

## TEACHING TIPS

**Resources:** Use only Church-produced resources in the nursery class. If you need more for the children to do, choose stories, games, puppets, or coloring activities from this manual that you have used previously. You can also use games and stories from the Church magazines.

**Repetition:** Teach all or parts of this lesson several times during the Christmas season. Children enjoy hearing the Christmas story again and again.





Jesus Christ Is the Son of  
Heavenly Father

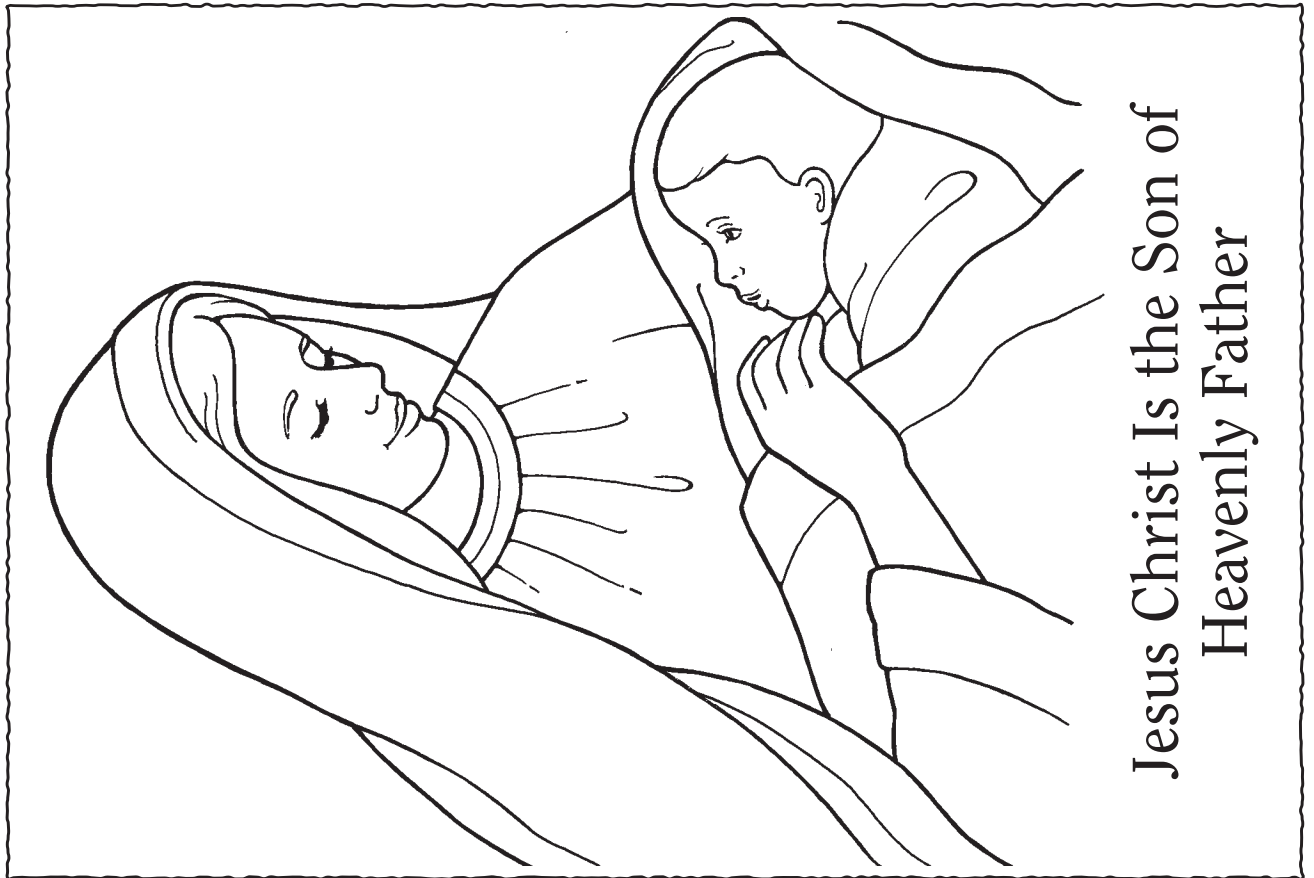

Jesus Christ Is the Son of  
Heavenly Father

# MINI-LESSON: WELCOME TO NURSERY

## LEARNING ACTIVITIES

**Welcome** When a child comes to the nursery class for the first time, choose a time when the children are gathered together (such as lesson, snack, or music time), and tell the children the new child's name. Tell the new child how glad you are that he or she is in the nursery class.

**Song** Tell the children that you would like to sing a special song. Sing or say the words to the "Hello Song" (*Children's Songbook*, 260) and ask the children to say "hello" when you point to them during the song. You may want to practice this a few times before you sing.

Hello! (*point to children: "Hello!"*)

Hello! (*point to children: "Hello!"*)

We welcome you today. (*point to children: "Hello!"*)

Hello! (*point to children: "Hello!"*)

Hello! (*point to children: "Hello!"*)

We're glad you came our way

To share with us our Primary day

And be our friend in a very special way.

Hello! (*point to children: "Hello!"*)

Hello! (*point to children: "Hello!"*)

We welcome you today.

**Conclusion** Say to the new child, "[Child's name], we are so happy that you are in our nursery class!"



## TEACHING TIPS

A child may approach his or her first time in nursery with eagerness or fear. By showing love and patience, you can do much to make each child's first experience in nursery enjoyable. Children are more comfortable when they know what to expect. As much as possible, try to follow a consistent routine in the nursery. Give new children time to get to know you, the other children, and the environment.

If the child wants to leave and be with his or her parents, let the parents know it is OK. Invite the parents to say positive things about nursery during the week.

## MINI-LESSON: HAPPY BIRTHDAY

### LEARNING ACTIVITIES

*Activity* On a Sunday near the child's birthday, while the children are gathered for the lesson, snack, or music time, tell the children, "[Child's name] has had [or will soon have] a birthday!" Invite the children to say, "Happy birthday."

Tell the children how old the child will be on his or her birthday. Invite them to count to that number with you on their fingers. Repeat a few times.

*Song* Sing or say the words to "Happy, Happy Birthday" (*Children's Songbook*, 284) and invite the children to join you:

Happy, happy birthday, [child's name], dear;  
Happy days will come to you all year.  
If I had one wish, then it would be  
A happy, happy birthday to you from me!  
Invite the children to say, "Happy birthday" and clap their hands.



### TEACHING TIPS

Children love to hear their names. The greatest gift you can give children is to love, recognize, and value them. Do not give other gifts for their birthdays in nursery. Celebrate the child, not gift giving.

## INDEX OF ACTIVITIES

### activity verses (first lines)

- “A baby in a manger,” 125
- “Daddy holds the baby,” 117
- “Heavenly Father knows me,” 20
- “The Holy Ghost speaks softly,” 29
- “I begin by saying ‘Dear Heavenly Father,’ ” 16
- “If you’re very, very tall,” 9
- “I have a special body,” 40
- “I want to follow Jesus,” 73
- “Joseph knelt among the trees,” 89
- “Open, shut them,” 85
- “Quietly I eat the bread,” 112, 117
- “Read the Book of Mormon,” 93
- “A smile is very catchy,” 81
- “Teach me the scriptures,” 97
- “This is Mother,” 56
- “This is my mother, who helps me at play,” 52
- “This little fellow is going to bed,” 45
- “Touch your eyes, touch your nose,” 65
- “When I am sick, I can be blessed,” 117

### bag games, 13, 37, 53, 93

books, 33, 35, 37, 39, 93, 95, 113, 115 (see also *flip books*)

bracelets, 69, 71

chains, 53, 55

cubes, 29, 31, 73, 75

figures, 48, 51, 101, 103

finger activity, 57

finger puppets, 41, 53, 57, 59, 89, 91

flip books, 17, 19, 85, 87, 117, 119

follow the leader, 100

guessing games, 45, 57, 59, 69, 71, 101, 103, 109, 111

guest, 113, 117

matching games, 65, 67, 105, 107

mirror, 21

mobile, 13, 15

necklaces, 21, 23, 57, 59, 69, 71

posters, 9, 49

puppets, 61, 63, 97, 99, 125, 127 (see also *finger puppets*)

puzzle, 25

role plays, 28, 44, 48, 61, 76, 100, 113

scriptures, 25, 29, 37, 52, 77, 104, 109, 112, 125

seed, 33

### songs

- “Away in a Manger,” 125
- “Baptism,” 108
- “The Church of Jesus Christ,” 104
- “Did Jesus Really Live Again?” 120
- “Families Can Be Together Forever,” 56
- “Family Prayer,” 52
- “Follow the Prophet,” 101
- “Fun to Do,” 36, 49, 72–73

“A Happy Family,” 36, 48

“Happy, Happy Birthday,” 129

“Head, Shoulders, Knees, and Toes,” 41

“Hello Song,” 128

“He Sent His Son,” 124

“I Am a Child of God,” 8, 12–13, 40

“I Feel My Savior’s Love,” 20–21

“If You’re Happy,” 81

“I Know My Father Lives,” 28

“I’m Trying to Be like Jesus,” 24, 68, 72

“I Love to See the Temple,” 56

“I Will Try to Be Reverent,” 84

“Jesus Has Risen,” 121

“Jesus Said Love Everyone,” 25, 76

“Love Is Spoken Here,” 116

“My Heavenly Father Loves Me,” 32

“On a Golden Springtime,” 88

“Once There Was a Snowman,” 44

“Quickly I’ll Obey,” 60

“Reverently, Quietly,” 36, 112

“Search, Ponder, and Pray,” 92, 96–97

“Smiles,” 80

“Thanks to Our Father,” 64–65

“The World Is So Lovely,” 33

### stories

boy comforted by the Holy Ghost, 28

children say “I’m sorry,” 69

Enos prays, 17

family prays for hurt child, 53

girl smiles, 80

good Samaritan, 76

Jesus and His mother, 49

Jesus blesses children, 20, 24, 96

Jesus feeds the people, 24

Jesus heals a blind man, 24

Jesus heals 10 lepers, 64

Jesus is resurrected, 120, 121

Joseph Smith’s First Vision, 40, 88

Nephi builds a ship, 68, 96

tracing, 41

verses (see *activity verses*)

## INDEX OF VISUALS

Adam and Eve, 99  
animals, 35  
baby blessing, 118, 119  
baptism, 110, 111  
blessing the sick, 119 (see also *Jesus Christ: healing*)  
body, 43, 47  
books, 75  
Church building, 31, 39  
clothes, 55, 67  
crayons, 75  
creations, 34, 35  
confirmation, 111  
Daniel in the lions' den, 103  
families, 14, 15, 18, 31, 38, 39, 46, 50, 51, 54, 55, 59, 62, 67  
First Vision, 42, 90, 91  
food, 19, 47, 55, 67, 75  
good Samaritan, 78  
home, 55, 67  
Jesus Christ, 19, 39, 106, 107, 115 (see also *First Vision*)  
    as a child, 18  
    baptism of, 110  
    birth of, 95, 126, 127  
    feeding the five thousand, 27  
    healing, 26, 66, 94, 95  
    Resurrection of, 122, 123  
    with children, 15, 22, 95, 98  
John the Baptist, 103, 110  
Joseph Smith, 102, 103, 107 (see also *First Vision*)  
Moses, 99  
Nephi, 70  
Noah, 99  
prayer, 18, 30, 54, 87  
pre-earth life, 15  
priesthood, 118, 119  
reverence, 86 (see also *prayer*)  
sacrament, 114, 115, 119  
Samuel the Lamanite, 103  
scriptures, 31, 39, 95, 107  
sharing, 74  
shepherds, 127  
smiling-frowning face, 83  
temple, 58, 59  
toys, 74, 75



## COPYRIGHTED VISUALS

Intellectual Reserve, Inc., holds the copyright to the paintings, photographs, and other images in this manual, with the following exceptions:

Front cover and page 22: *Christ and the Book of Mormon Children*, by Del Parson. © 1995 Del Parson.

Page 5: Photo © 2000 Steve Bunderson.

Page 8: Photo © Rubberball Productions.

Page 18: *In Favor with God*, by Simon Dewey.  
© 2001 Simon Dewey. Do not copy.

Pages 24 and 98: *Storytime in Galilee*, by Del Parson.  
© 1990 Del Parson.

Page 28: Photo © 1998 Robert Casey.

Page 32: Photo © Corbis Images.

Page 42: *The First Vision*, by Gary Kapp.  
© 1998 Gary Kapp. Do not copy.

Page 48: Photo © 2000 Steve Bunderson.

Page 54: Photo © 2006 Hyun-Gyu Lee.

Page 56: Photo © 2006 Frank Helmrich.

Page 66: *The Leper Who Said "Thank You,"* by John Steel.  
© ProvidenceCollection.com. All rights reserved.

Page 88: *Joseph Smith's First Vision*, by Greg K. Olsen.  
© 1988 Greg K. Olsen.

Page 90: *The Desires of My Heart*, by Walter Rane.  
© 2004 Walter Rane, courtesy of the Museum of Church History and Art.

Page 94: *And He Healed Them Every One*, by Gary Kapp.  
© 1993 Gary Kapp.

Page 102: *Brother Joseph*, by David Lindsley.  
© 1998 David Lindsley.

Page 106: Detail from *Christ and the Rich Young Ruler*,  
by Heinrich Hofmann. Courtesy of C. Harrison Conroy  
Co., Inc.

Page 110: *John the Baptist Baptizing Jesus*,  
by Greg K. Olsen. © 1988 Greg K. Olsen.

Page 120: *He Is Risen*, by Del Parson. © 1996 Del Parson.

Page 124: *For unto Us a Child Is Born*, by Lynne Millman  
Weidinger. © 2002 Lynne Millman Weidinger, courtesy  
of the Museum of Church History and Art.

Page 126: *Mary and the Christ Child*, by Robert T. Barrett.  
© 1993 Robert T. Barrett. Do not copy.

Page 128: Photo © 1999 Bryant Livingston.



*“All thy children shall be taught of the Lord; and great shall be the peace of thy children”  
(3 Nephi 22:13).*

*“[Jesus] spake unto the multitude, and said unto them: Behold your little ones. And as they looked to behold they cast their eyes towards heaven, and they saw the heavens open, and they saw angels descending out of heaven as it were in the midst of fire; and they came down and encircled those little ones about, and they were encircled about with fire; and the angels did minister unto them” (3 Nephi 17:23–24).*

*“Clearly, those of us who have been entrusted with precious children have been given a sacred, noble stewardship, for we are the ones God has appointed to encircle today’s children with love and the fire of faith and an understanding of who they are” (M. Russell Ballard, “Great Shall Be the Peace of Thy Children,” Ensign, Apr. 1994, 60).*

THE CHURCH OF  
**JESUS CHRIST**  
OF LATTER-DAY SAINTS

